

Remote Control Valve

(Electric speed controller)

New



The speed controller is equipped with a motor

Speed controller capable of “remote control” by “electrification”

Large reduction in equipment setup time and downtime

Easy maintenance

Improved productivity

Reduced adjustable work-hours

Reduced down time



Remote control

The actuator speed and device flow rate can be adjusted “from a remote location,” “without going to the site,” and “without stopping the device.”

Electrification

Adjustment is possible **without manual work and simultaneously**

PFES Series



CAT.ES100-175A

Avoid speed adjustment problems

Ex. When an abnormal operation occurs due to a speed change of the actuator.

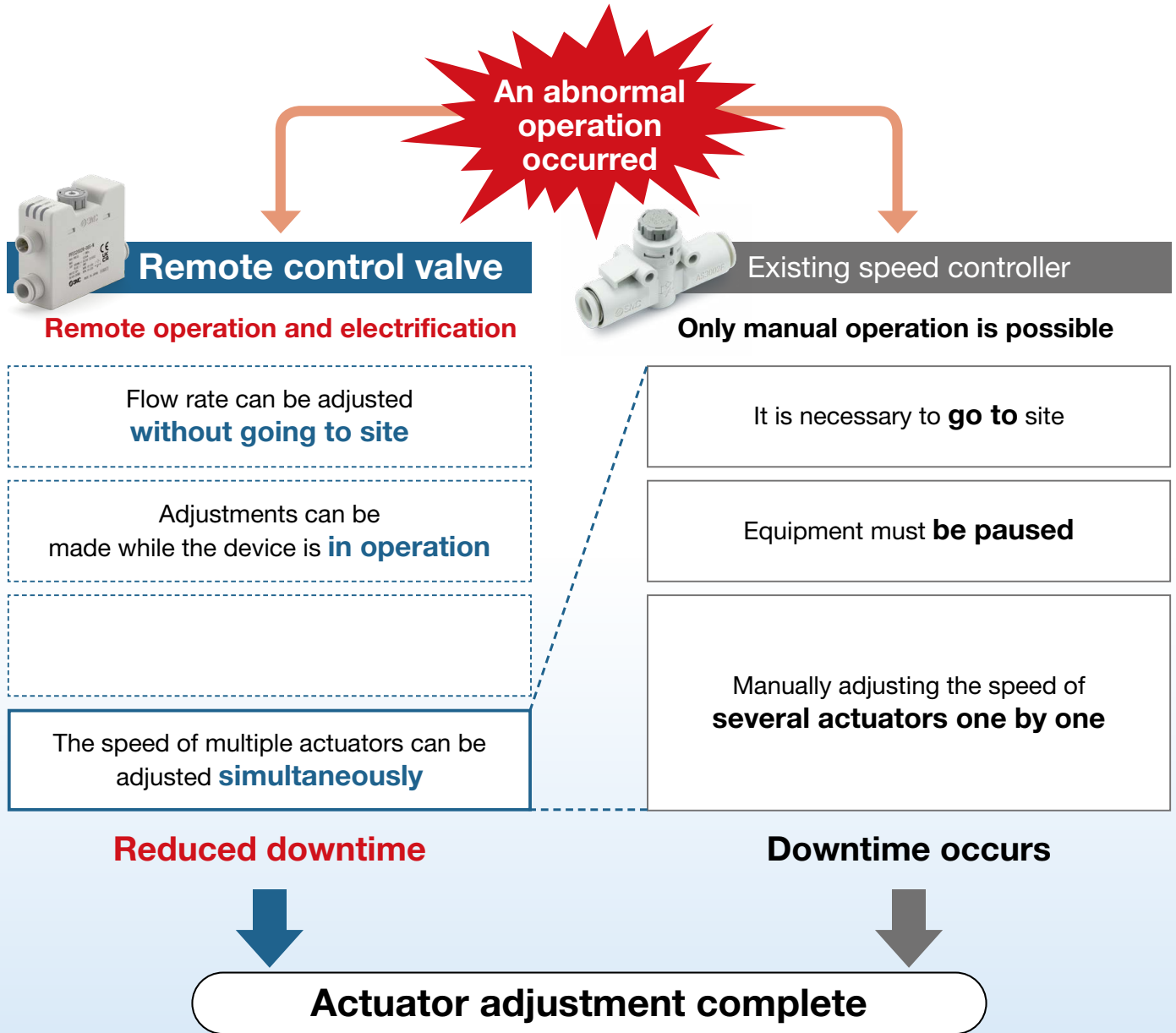

Remote control

- Even in dangerous, high or narrow locations, the speed of the actuator can be adjusted remotely without going to site.
→ **Reduced adjustment work-hours / working risk reduced / easier maintenance.**
- Adjust actuator speed without pausing the equipment.
→ **Improved productivity/reduced downtime**

Electrification

- Adjust multiple devices at once → **Reduced adjustment work-hours**
- Reduces variations caused by manual operation → **Improved productivity**
- Set-up is simplified by electrification → **Reduced adjustment work-hours**

Easy, simple operation

- Set-up can be made quantitatively using electrical control.
- Opens and closes with one electrical signal pulse
- Simply input the flow rate UP/DOWN signal from a PLC or touch panel.
- No dedicated controller or PLC positioning unit is required, making installation easy.

Select input pulse according to needle control angle.

Needle control angle.	Input pulse		Fully closed → Fully open (5.5 turns)	
	Pulse width	Pulse period	Number of pulses required	Time required
5°	50 ms	0.7 s	396 times	277.2 s
30°	0.5 s	1.2 s	66 times	79.2 s
180°	1.0 s	2.2 s	11 times	24.2 s

* Take care about the number of consecutive operations (refer to p. 14).

Pin No.	Wire color	Pin Assignment
1	Brown	DC + (24 V ±10%)
2	White	NPN or PNP input... flow rate UP
3	Blue	DC - (0 V)
4	Black	NPN or PNP input... flow rate DOWN

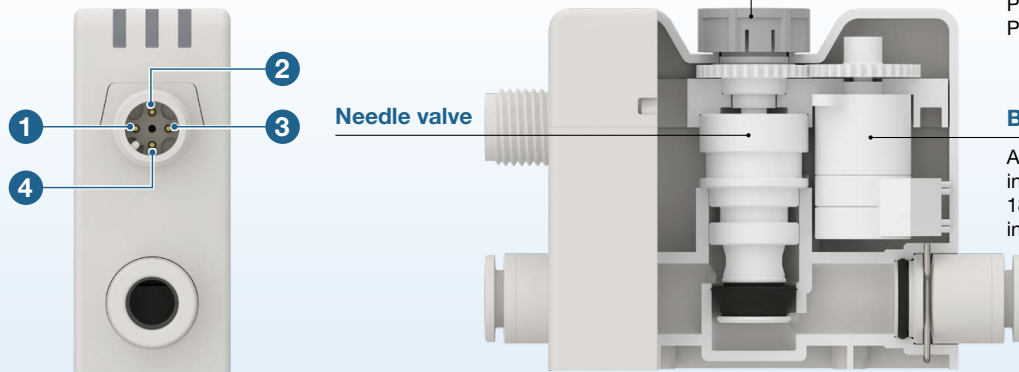

Knob

Push: Auto Adjust (remote control)
Pull: Manual adjustment (remote control lock)

Built-in Step motor

Adjusts the needle valve angle in increments of 5°, 30°, and 180° according to the external input signal (open loop control).

Example: When opening from 0° to 360° (1 rotation)

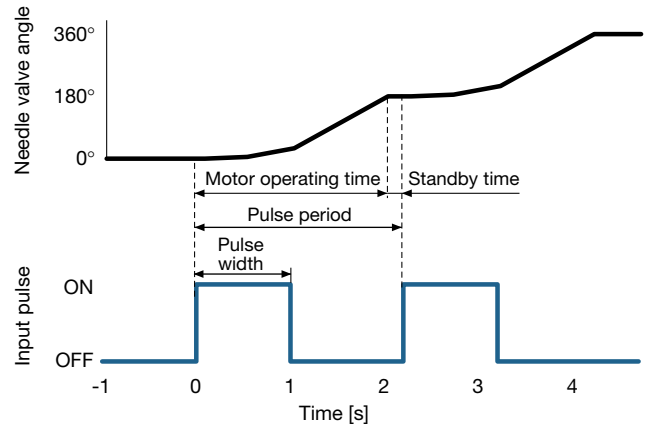

Knob operation

- If electrical signals cannot be sent immediately, on-site manual adjustment is possible using the knob.
(Conventional equipment startup is also possible)



The needle valve angle is maintained even when the power is turned OFF.

- The needle valve angle does not change even before and after power failure, so readjustment is not required when restarting.
- Once the needle valve angle is set, no power supply is required, allowing for energy saving.

Grease-free

Application Examples

Adjusting actuator speed in difficult environments.

- Remote adjustment results in easy maintenance.

Difficult working environments

Heights

- Unable to reach

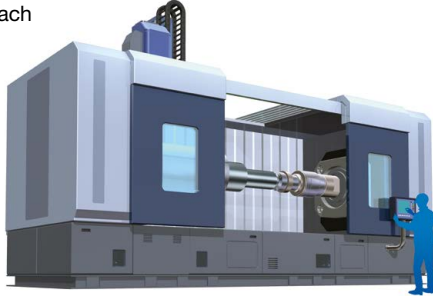

Ex. Robot hands / High position transfer location / Opening and closing ceiling shutters.

Narrow spaces

- Hands and tools cannot enter

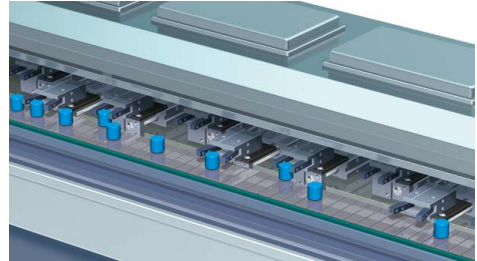

Ex. Incorporated Equipment/Limited maintenance space

Shielded area

- Adjustment from outside is difficult during operation.



Ex. Equipment cover and frame Interior/ dustproof cover Installation/ Equipment Operation

Difficult to access environments

Hazardous location

- Restricted access



Ex. Working area/hazardous area enclosed by safety fence

Quarantine areas

- Workwear and cleaning required



Ex. Clean room / electrostatic prevention process

Distant places

- Places not often accessed

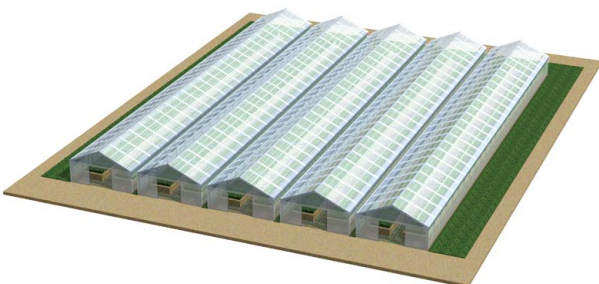

Ex. Cultivation house / Long-term facility with many processes

Application Examples

Infrequent changeovers / simple flow rate adjustments

- Increased productivity by making equipment / lines more versatile

Actuator speed Adjustment

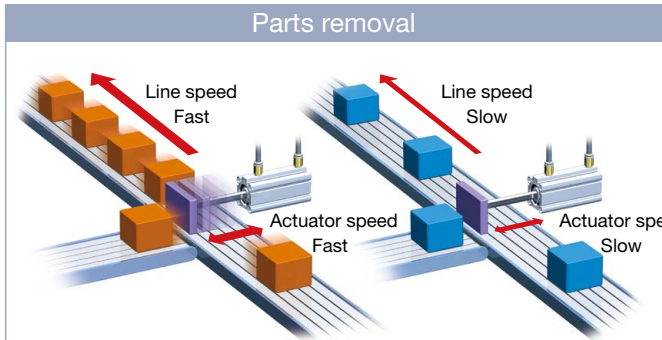

Ex. Adjust speed of dispensed parts by an actuator according to the size of workpiece and line speed.
(Prevent workpiece blowing/interference with the next workpiece)

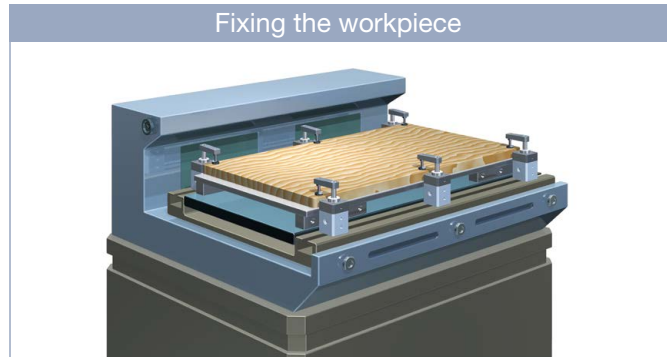

Ex. Adjusts clamp speed according to the wood thickness in wood working machinery.
(Prevent clamp fault/workpiece deformation)

Blow/Purge flow rate adjustment

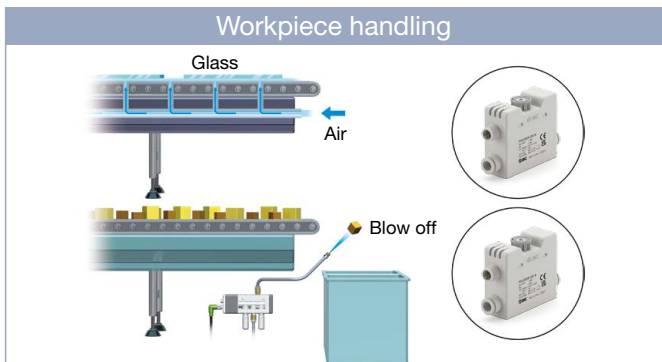

Ex. Adjust the flow rate for floating and blowing off according to the size of workpiece.
(Prevent carry transmission error/workpiece blowout)

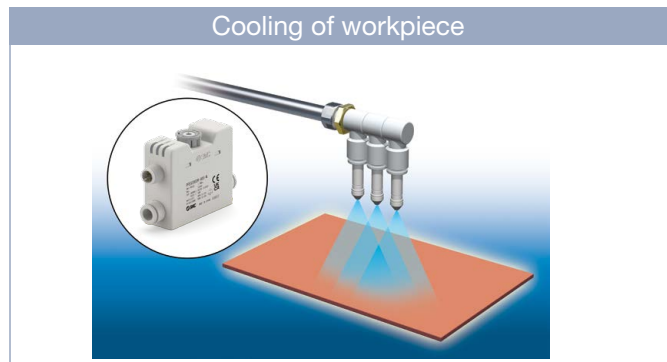

Ex. Adjust the cooling flow rate according to the workpiece (Prevent temperature control failure)

Application Examples

Electrical flow regulation for repeatable control

- Eliminates manual work, reduces adjustment man-hours, and reduces equipment downtime

Adjustment of the operating air flow rate for fluid control equipment

Diaphragm pump flow rate adjustment

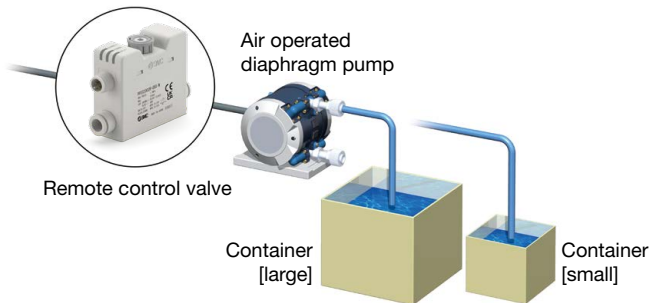

Ex. Adjust the pump output flow rate according to the container volume

Diaphragm valve opening and closing speed adjustment

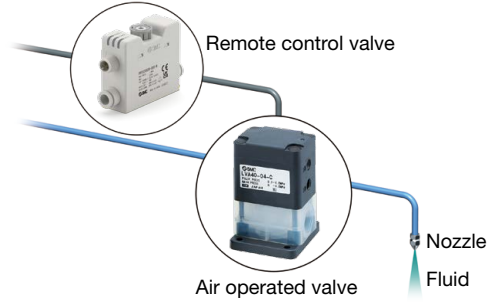

Ex. Fine-tuning chemicals level at nozzle tip

Adjustment of vacuum ejector supply / burst air flow

Vacuum pressure adjustment for vacuum ejector

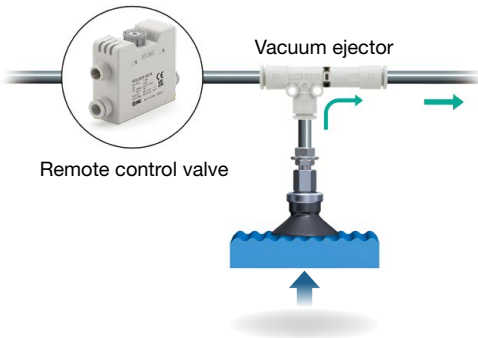

Ex. Depending on the unevenness of the workpiece, the flow rate supplied to the ejector is changed and the vacuum pressure is adjusted.

Adjustment of vacuum air release

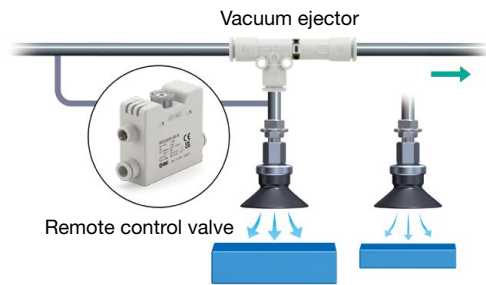

Ex. Adjust air flow rate when releasing the vacuum according to the work size

- Reduced human error and improved production quality / automation of equipment and labor saving.

Adjustment without manual intervention

Reduced human error

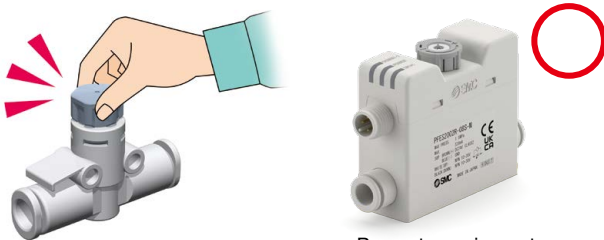

Prevents equipment operation failure due to incorrect settings

Ex. Prevents incorrect RPM settings

■ Application Examples

Adjustment according to operating conditions

- Contributes to efficient production and air saving measures

Improving equipment efficiency

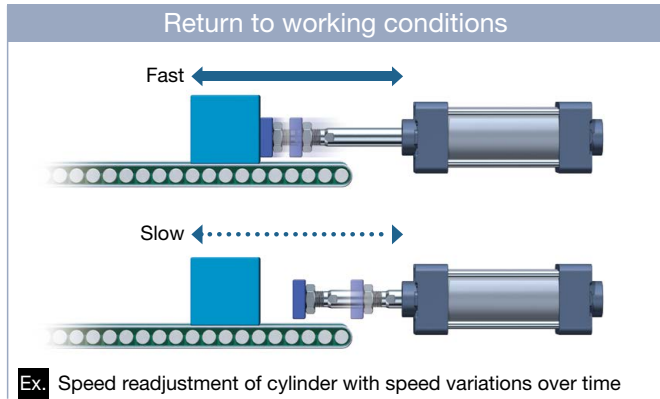

Saving air consumption over time

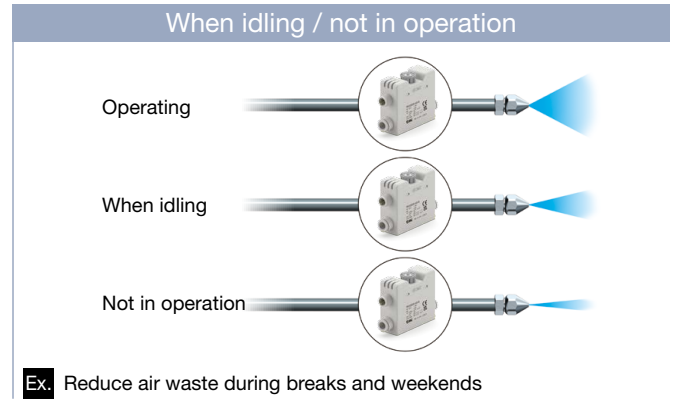

Bulk configuration and centralized management of multiple devices

- Bulk settings / centralized control reduces adjustment work hours and equipment downtime

Setting / management via touch panel and PLC

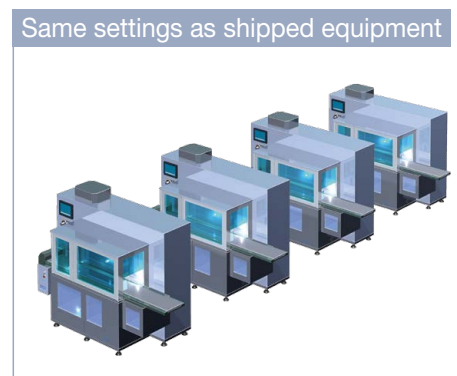
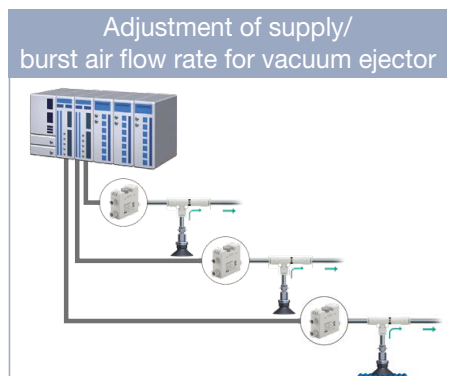
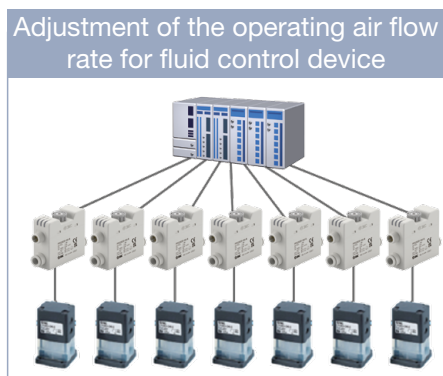
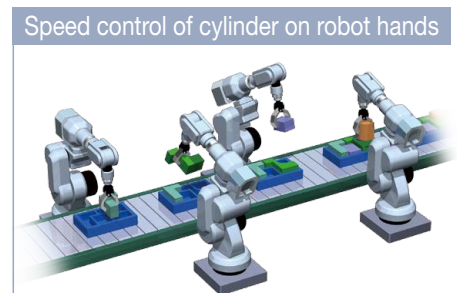
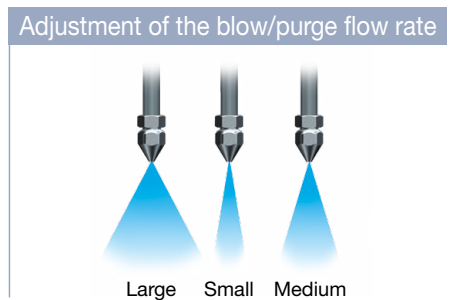
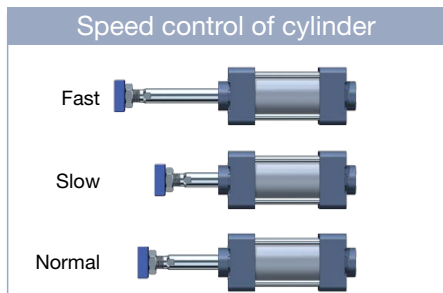
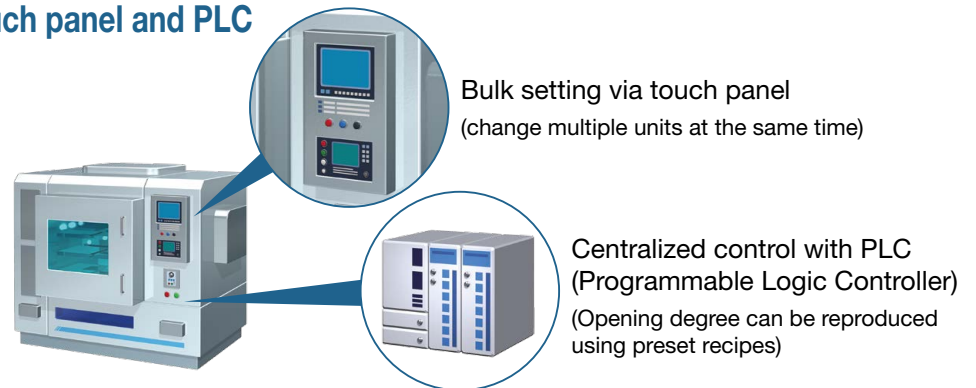

CONTENTS

Remote Control Valve (Electric speed controller) *PFES Series*

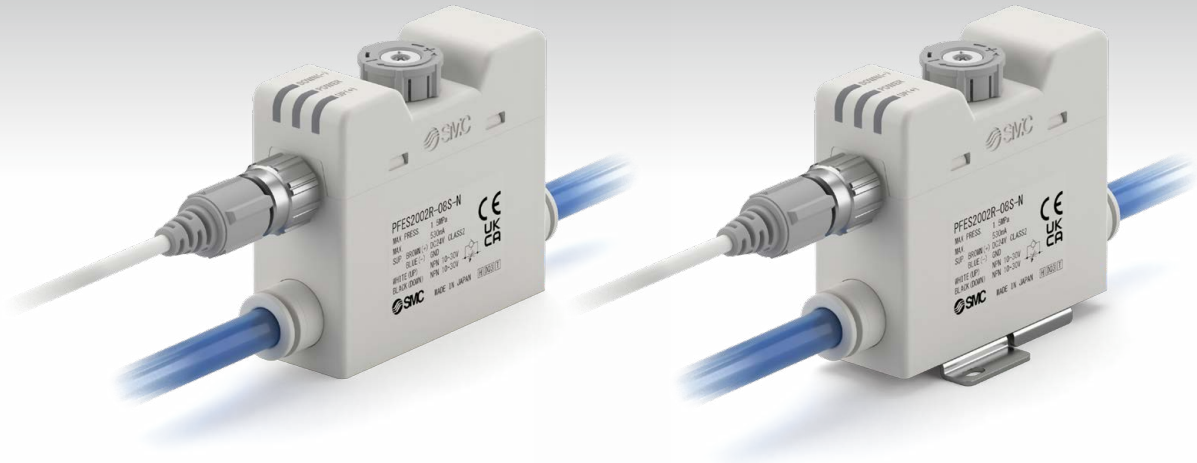

How to Order	p. 8
Specifications	p. 8
Flow Rate Characteristics	p. 9
Input Pulse Count and Number of Knob Rotations	p. 9
Internal Circuits and Wiring Examples	p. 9
Construction	p. 10
Dimensions	p. 10
Accessories	p. 11
Specific Product Precautions	p. 14
Safety Instructions	Back cover

Remote Control Valve (Electric speed controller) **PFES Series**

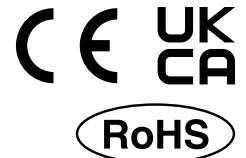

How to Order

PFES 1001 R-04 S-N-L R

Flow rate type

1001	Small flow
1002	Low flow
2002	Intermediate flow
3002	High flow

Port size

04	ø4
06	ø6
08	ø8

Piping entry direction

S	Straight
---	----------

Option 2

R	Bracket
Z	None

Option 1

L	With lead wire and M12 connector
Z	Without lead wire

Input specification

N	NPN input
P	PNP input



Accessories / Part Numbers

When optional parts are required separately, use the following part numbers to place an order.

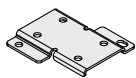
Description	Part number	Note
Lead wire with M12 connector Straight	ZS-37-A	Lead wire length 3 m 
Bracket	ZS-58-A	Self-tapping screw: Nominal size 3 x 6 L (4 pcs.) 

Specifications

Fluid	Applicable fluid	Air (JIS B8392-1: 2012 [6.6.5], ISO8573-1: 2010 [6.6.5])
	Fluid temperature range	0 to 50°C
Pressure	Rated pressure range	0.1 to 0.8 MPa
	Withstand pressure	1.5 MPa
Electrical	Power supply voltage	24 VDC ±10%
	Current consumption	Standby: 13 mA or less, Operation: 530 mA or less
Control specification	Input type	NPN PNP
	Input current	1 mA or less
	Needle control angle (signal input time)	5° (above 50 ms, below 0.5 s), below 0.5 s
		30° (above 0.5 s, below 1.0 s), below 1.0 s
Response time	180° (1.0 s or more), 2.0 s or less	
Display (LED)	UP (+)	LED is ON when needle is rotating (Green)
	POWER	LED is ON when power supply is ON (amber)
	DOWN (-)	LED is ON when needle is rotating (Green)
Standards		CE / UKCA
Environment	Operating temperature range	0 to 50°C
	Enclosure rating	IP40
	Materials of parts in contact with fluid	PBT, Brass (Electroless nickel plating), FKM, Urethane rubber

PFES Series

Flow Rate Characteristics

PFES1001R (0.5 MPa)

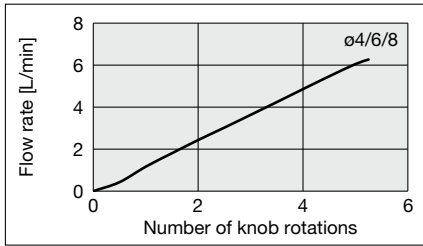

PFES1002R (0.5 MPa)

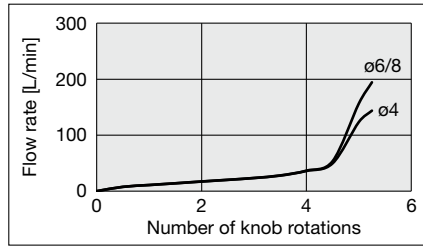

PFES2002R (0.5 MPa)

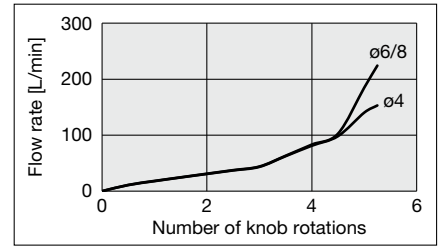

PFES3002R (0.5 MPa)

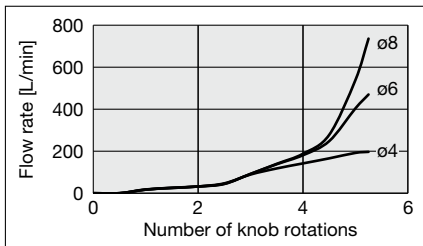

Input Pulse Count and Number of Knob Rotations

Needle Control Angle: 5°

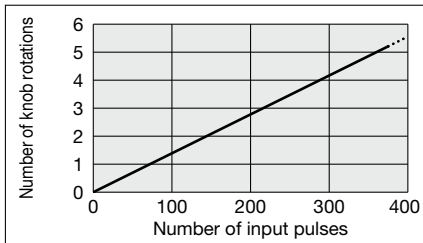

Needle Control Angle: 30°

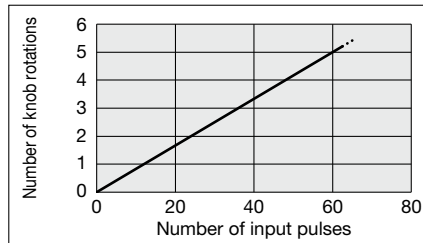

Needle Control Angle: 180°

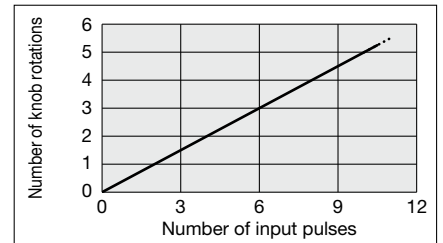

* The dotted lines on the graph are reference values.
(Fully closed ↔ Fully open: approx. 5.5 turns)

Internal Circuits and Wiring Examples

<NPN input type>

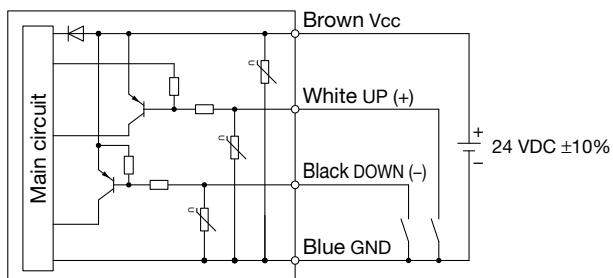

<PNP input type>

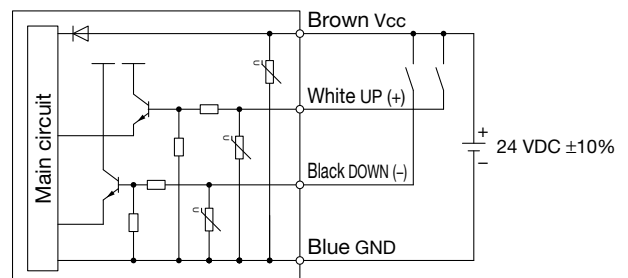

Construction

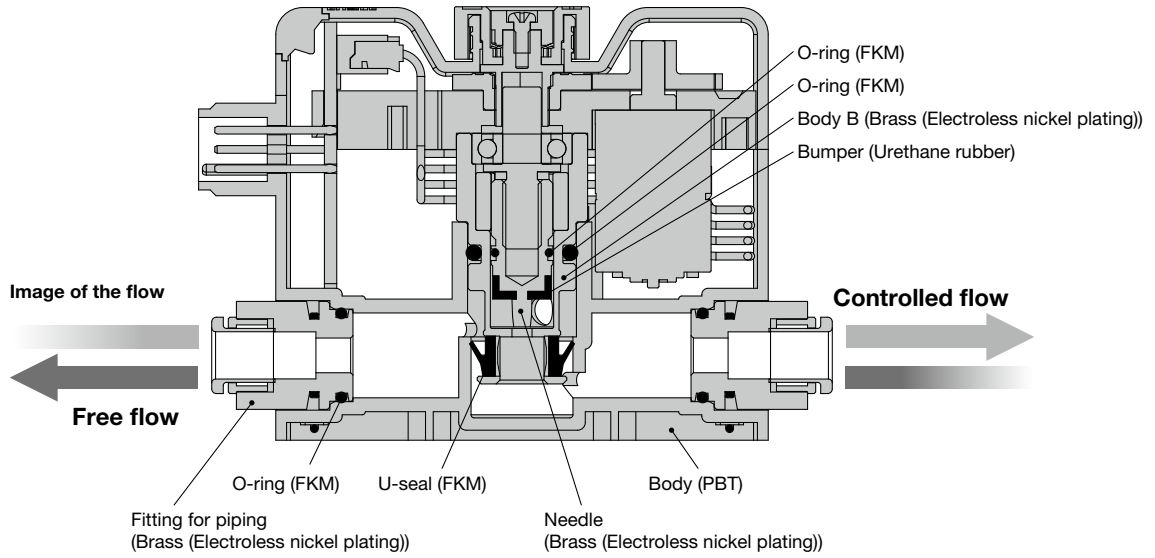

Dimensions

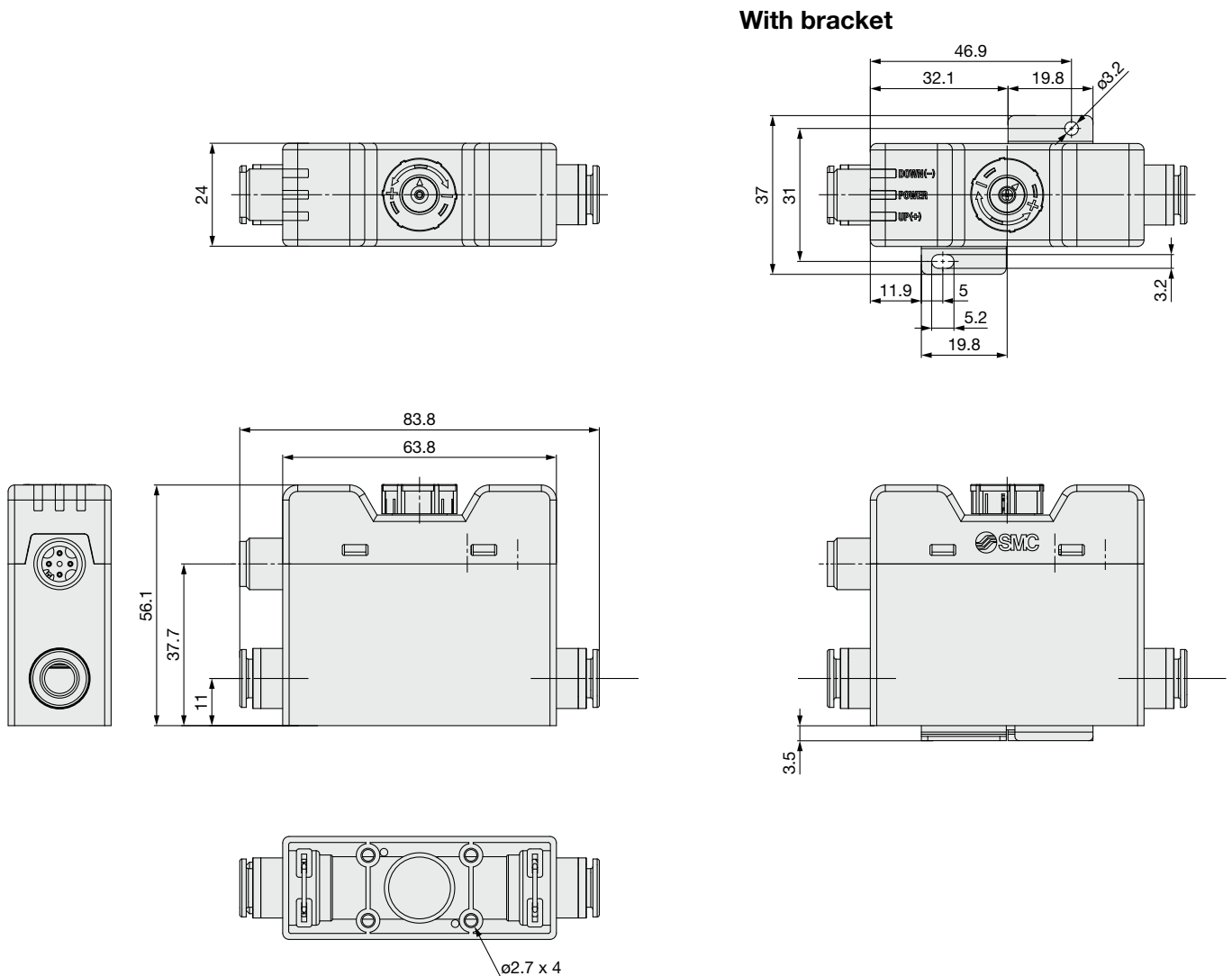

PFES Series Accessories

① Lead Wire with M12 Connector

Accessory part number: **ZS-37-A**

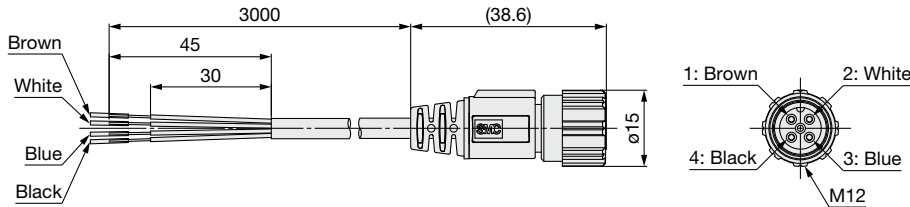

Cable Specifications

Conductor	Nominal cross section	AWG23
	Outside diameter	0.72 mm
Insulator	Material	Cross-linked vinyl
	Outside diameter	1.14 mm
	Number of cores	4
Sheath	Material	Oil-resistant vinyl
	Outside diameter	ø4

② Bracket

Accessory part number: **ZS-58-A**

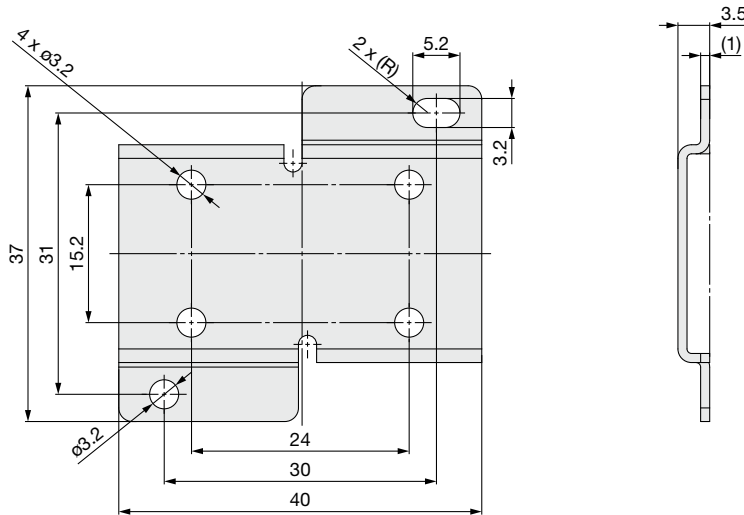

③ Lead Wire with M12-M12 Connector

EX9-AC **005** -SSPS

● Cable length (L)

005	500 mm
010	1000 mm
020	2000 mm
030	3000 mm
050	5000 mm
100	10000 mm

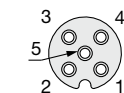
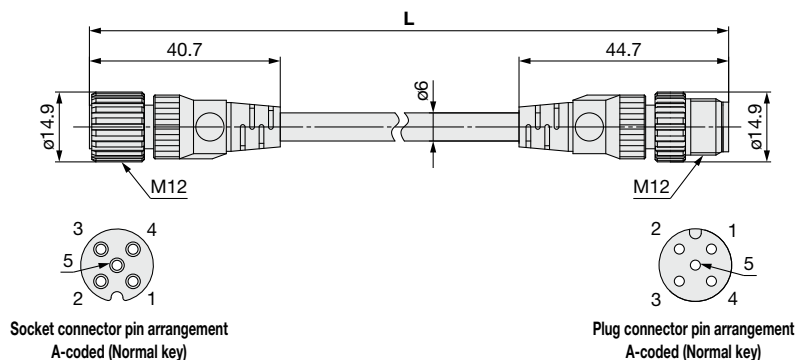

Socket connector pin arrangement
A-coded (Normal key)

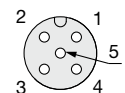

Plug connector pin arrangement
A-coded (Normal key)

Terminal no.	Core wire color
1	Brown
2	White
3	Blue
4	Black
5	Gray

Connections

Item	Specifications
Cable O.D.	ø6 mm
Conductor nominal cross section	0.3 mm ² /AWG22
Wire O.D. (Including conductor)	1.5 mm
Min. bending radius (Fixed)	40 mm

④ T-branch Connector

LEC-CGD

• Branch connector

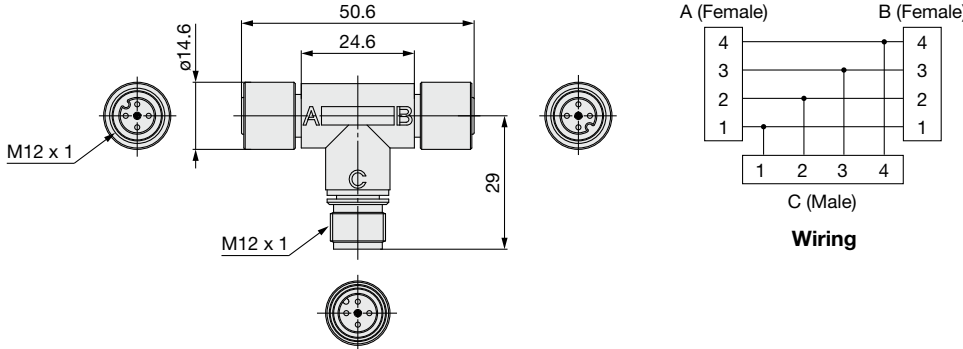

⑤ Fieldwireable Connector (M12 plug)

PCA-1557756

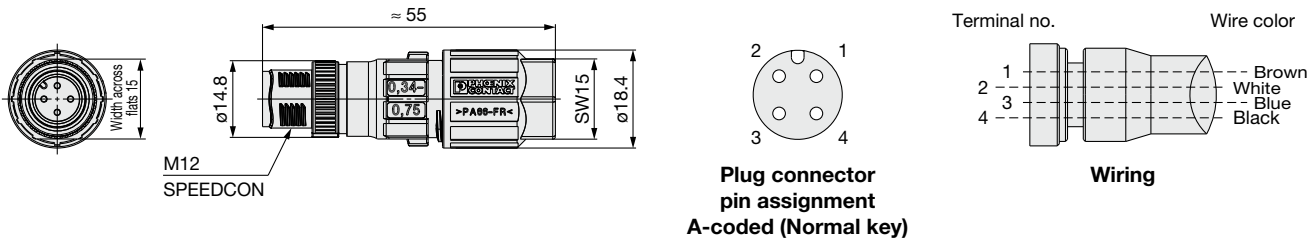

⑥ Lead Wire with M12 Connector (Plug)

EX9-AC 030 -7

• Cable length (L)

010	1000 [mm]
030	3000 [mm]

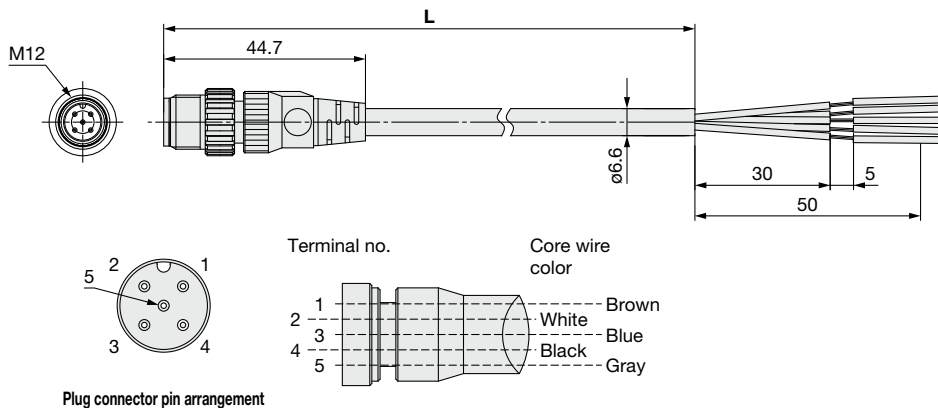

Item	Specifications
Cable O.D.	$\phi 6.6$ mm
Conductor nominal cross section	0.3 mm ² /AWG22
Wire O.D. (Including conductor)	1.65 mm
Min. bending radius (Fixed)	40 mm

PFES Series

EX600-DY□ Digital Output Unit Connection Example

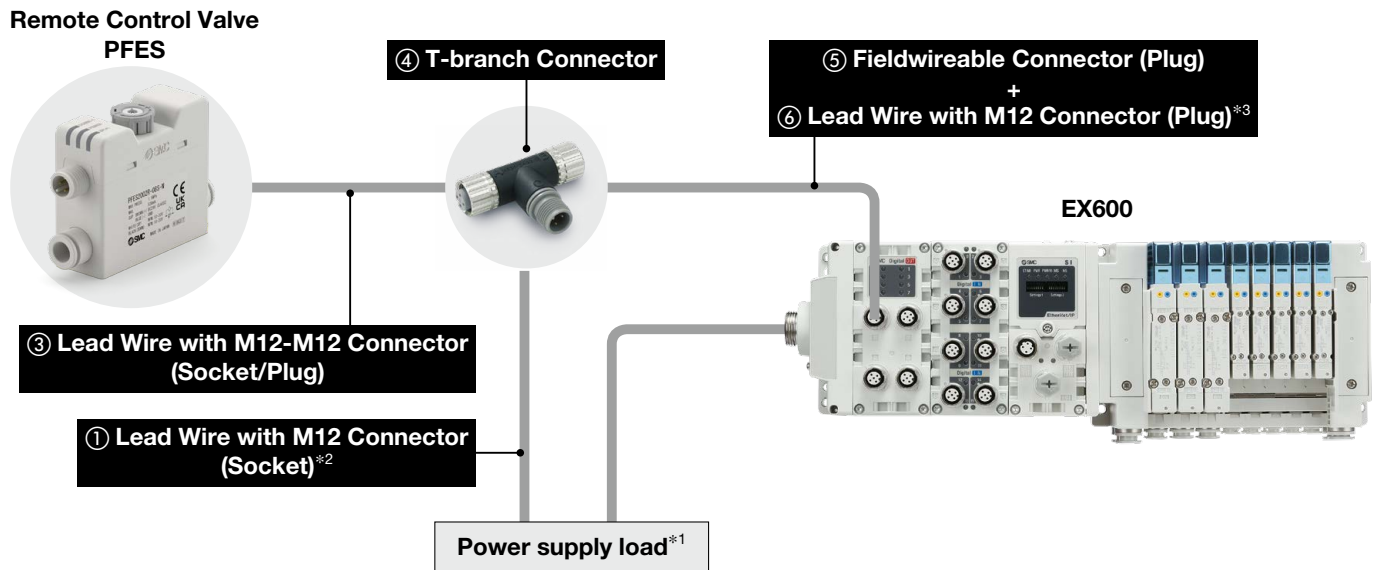

- *1 Be sure to use a common power GND for the PFES and EX600-ED.
- *2 Connect terminal no. 1 and 3 to DC (+) and DC (-) respectively, and leave terminal no. 2 and 4 unconnected.
- *3 Connect terminal no. 2 and 4, and leave terminal no. 1 and 3 unconnected.

Wiring image

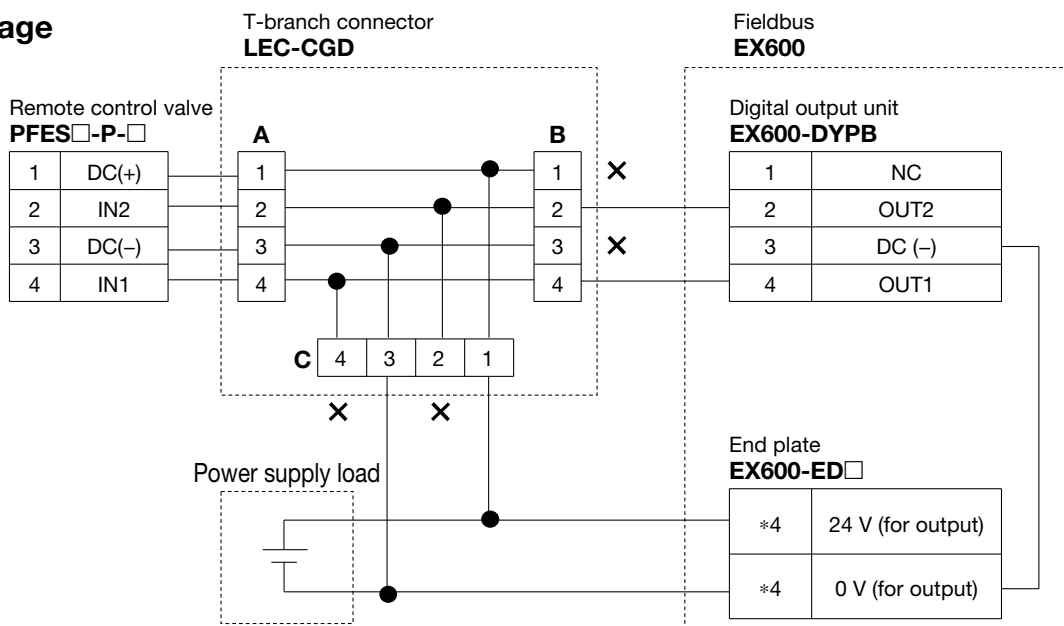

- *4 Note that due to the EX600-ED□ end plate specifications, the wiring specifications will vary.



PFES Series

Specific Product Precautions

Be sure to read this before handling the products. Refer to the back cover for safety instructions. For flow control equipment precautions, refer to the “Handling Precautions for SMC Products” and the “Operation Manual” on the SMC website: <https://www.smcworld.com>

Design/Selection

Warning

1. Cannot be used as a stop valve.

Zero leakage is not guaranteed.

2. When power supply is turned OFF, knob does not return to closed position.

The aperture open / close does not change even when the power is turned OFF.

The aperture open / close angle will not change before or after a power failure.

3. Do not use for applications which require constant operation, such as controlling the flow rate by feeding back the flow rate value.

This may accelerate age deterioration and may result in a failure.

4. When performing continuous operation, do not exceed the continuous input pulse count upper limit. If you wish to exceed the upper limit of the consecutive input pulse count, provide a signal input interval.

Continuous input pulse count upper limit

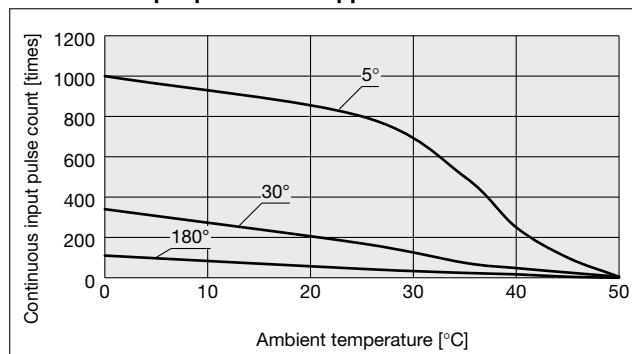

Signal input interval

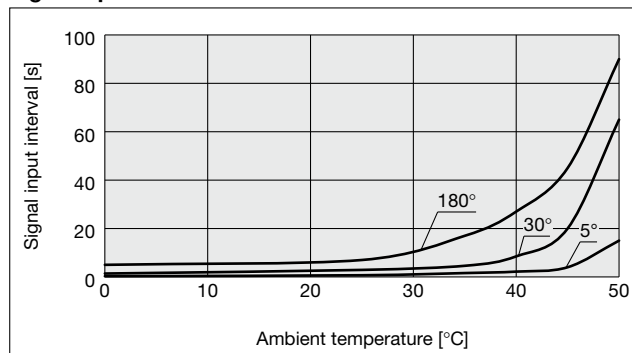

5. Knob operation

Forcing the manual knob to turn may result in a failure.

From fully closed to fully open takes 5.5 turns.

The aperture is set to 1.5 turns open from the fully closed position when shipped from the factory.

6. Do not turn input control signal when pressure exceeds 0.8 MPa.

The needle may not turn rotation.

If workload weight is heavy in vertical use case of cylinder, meter-out control may have a higher exhaust's back pressure than supply pressure when cylinder go down. In such cases, turn input control signal while cylinder is stopped. And cylinder output force of descent direction can be reduced by a pressure regulator with a reverse-current function to reduce back pressure.

Operating Life

The operating lifetime of this product is under the following conditions.

(1) Target operation: Fully closed → Fully open → Fully closed (to the end)

Operating lifetime: 10,000 operations (reference value)

Operating pressure: 0.2 MPa constant

Ambient temperature: 20 to 25°C

(2) Target operation: Open and closed in the middle open range.

Operating lifetime: 300,000 operations (reference value)

Operating pressure: 0.2 MPa constant

Ambient temperature: 20 to 25°C

Safety Instructions

These safety instructions are intended to prevent hazardous situations and/or equipment damage. These instructions indicate the level of potential hazard with the labels of “**Caution**,” “**Warning**” or “**Danger**.” They are all important notes for safety and must be followed in addition to International Standards (ISO/IEC)*1), and other safety regulations.

 **Danger :** **Danger** indicates a hazard with a high level of risk which, if not avoided, will result in death or serious injury.

 **Warning:** **Warning** indicates a hazard with a medium level of risk which, if not avoided, could result in death or serious injury.

 **Caution:** **Caution** indicates a hazard with a low level of risk which, if not avoided, could result in minor or moderate injury.

*1) ISO 4414: Pneumatic fluid power - General rules and safety requirements for systems and their components
ISO 4413: Hydraulic fluid power - General rules and safety requirements for systems and their components
IEC 60204-1: Safety of machinery - Electrical equipment of machines - Part 1: General requirements
ISO 10218-1: Robots and robotic devices - Safety requirements for industrial robots - Part 1: Robots etc.

Warning

1. The compatibility of the product is the responsibility of the person who designs the equipment or decides its specifications.

Since the product specified here is used under various operating conditions, its compatibility with specific equipment must be decided by the person who designs the equipment or decides its specifications based on necessary analysis and test results. The expected performance and safety assurance of the equipment will be the responsibility of the person who has determined its compatibility with the product. This person should also continuously review all specifications of the product referring to its latest catalog information, with a view to giving due consideration to any possibility of equipment failure when configuring the equipment.

2. Only personnel with appropriate training should operate machinery and equipment.

The product specified here may become unsafe if handled incorrectly. The assembly, operation and maintenance of machines or equipment including our products must be performed by an operator who is appropriately trained and experienced.

3. Do not service or attempt to remove product and machinery/equipment until safety is confirmed.

1. The inspection and maintenance of machinery/equipment should only be performed after measures to prevent falling or runaway of the driven objects have been confirmed.
2. When the product is to be removed, confirm that the safety measures as mentioned above are implemented and the power from any appropriate source is cut, and read and understand the specific product precautions of all relevant products carefully.
3. Before machinery/equipment is restarted, take measures to prevent unexpected operation and malfunction.

4. SMC products cannot be used beyond their specifications. They are not developed, designed, and manufactured to be used under the following conditions or environments. Use under such conditions or environments is not allowed.

1. Conditions and environments outside of the given specifications, or use outdoors or in a place exposed to direct sunlight.
2. Use for nuclear power, railways, aviation, space equipment, ships, vehicles, military application, equipment affecting human life, body, and property, combustion equipment, entertainment equipment, emergency shut-off circuits, press clutches, brake circuits, safety equipment, etc., and use for applications that do not conform to standard specifications such as catalogs and operation manuals.
3. Use for interlock circuits, except for use with double interlock such as installing a mechanical protection function in case of failure. Please periodically inspect the product to confirm that the product is operating properly.

Caution

SMC develops, designs, and manufactures products to be used for automatic control equipment, and provides them for peaceful use in manufacturing industries.

Use in non-manufacturing industries is not allowed.

Products SMC manufactures and sells cannot be used for the purpose of transactions or certification specified in the Measurement Act of each country. The new Measurement Act prohibits use of any unit other than SI units in Japan.

Limited warranty and Disclaimer/ Compliance Requirements

The product used is subject to the following “Limited warranty and Disclaimer” and “Compliance Requirements”.

Read and accept them before using the product.

Limited warranty and Disclaimer

1. The warranty period of the product is 1 year in service or 1.5 years after the product is delivered, whichever is first.*2)
Also, the product may have specified durability, running distance or replacement parts. Please consult your nearest sales branch.
2. For any failure or damage reported within the warranty period which is clearly our responsibility, a replacement product or necessary parts will be provided.
This limited warranty applies only to our product independently, and not to any other damage incurred due to the failure of the product.
3. Prior to using SMC products, please read and understand the warranty terms and disclaimers noted in the specified catalog for the particular products.

*2) **Suction cups (Vacuum pads) are excluded from this 1 year warranty.**

A suction cup (vacuum pad) is a consumable part, so it is warranted for a year after it is delivered.

Also, even within the warranty period, the wear of a product due to the use of the suction cup (vacuum pad) or failure due to the deterioration of rubber material are not allowed by the limited warranty.

Compliance Requirements

1. The use of SMC products with production equipment for the manufacture of weapons of mass destruction (WMD) or any other weapon is strictly prohibited.
2. The exports of SMC products or technology from one country to another are governed by the relevant security laws and regulations of the countries involved in the transaction. Prior to the shipment of a SMC product to another country, assure that all local rules governing that export are known and followed.

Safety Instructions

Be sure to read the “Handling Precautions for SMC Products” (M-E03-3) and “Operation Manual” before use.