

Compatible with Manifold Controller



Electric Actuators

Slider Type/Rod Type/Guide Rod Type/ Slide Tables/Rotary Table

Battery-less Absolute (Step Motor 24 VDC)

New

Slide Table/Compact Type

Size: 16, 25

LE2S□H Series

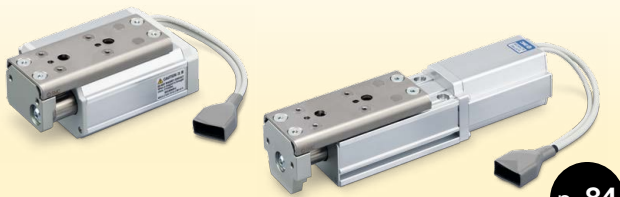

p. 84

New

Slide Table/High Rigidity Type

Size: 16, 25

LE2SH□H Series



p. 84

Slider Type/Ball Screw Drive

Size: 16, 25, 32, 40

LE2FS□H Series

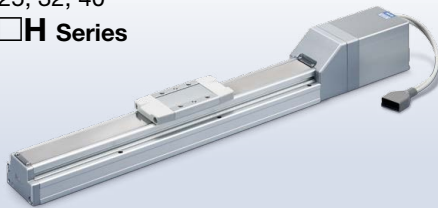

p. 6

Slider Type/Belt Drive

Size: 16, 25, 32

LE2FB□H Series

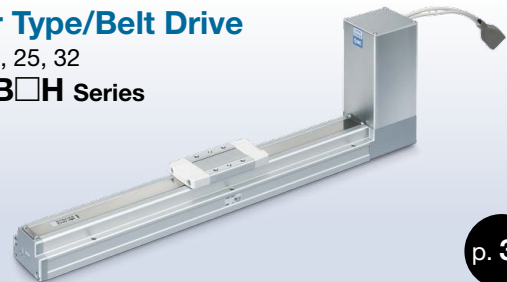

p. 30

Rod Type

Size: 16, 25, 32

LE2Y□H Series



p. 42

Guide Rod Type

Size: 16, 25, 32

LE2YG□H Series



p. 62

Rotary Table

Size: 30, 50

LE2R□H Series



p. 122

Annual CO₂ emissions:

Max. 38% reduction

(SMC comparison)

p. 1

8.7 kg-CO₂e/year (14.1)

* The numerical values vary depending on the operating conditions.

Manifold Controller

Up to **16 axes** can be connected

Scan or click here for details.



LE2F□□H/LE2Y(G)□H Series LE2S(H)□H/LE2R□H Series



CAT.ES100-170D

Electric Actuators Slider Type/Rod Type/Guide Rod Type/Slide Tables/Rotary Table

LE2F□□H/LE2Y(G)□□H/LE2S(H)□□H/LE2R□□H Series

Battery-less Absolute (Step Motor 24 VDC)

Annual CO₂ emissions reduced by up to 38% through motor control optimization (SMC comparison)

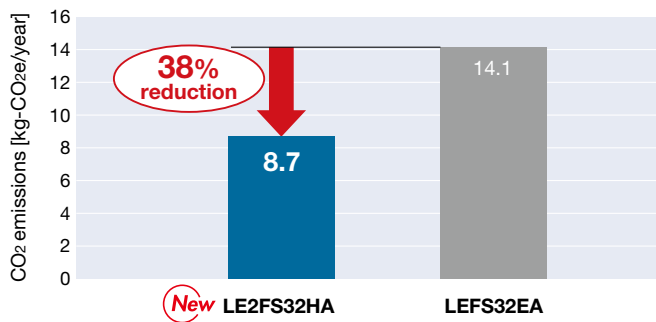

Operating conditions: • Slider type, Size 32 • Speed: 50 mm/s
• Acceleration/Deceleration: 3000 mm/s² • Duty ratio: 20%

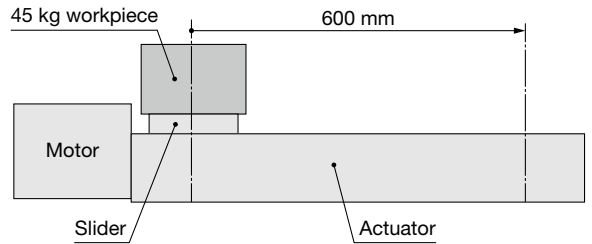

* The numerical values vary depending on the operating conditions.

Select from 5 cable entry directions

p. 18, 34, 50, 73

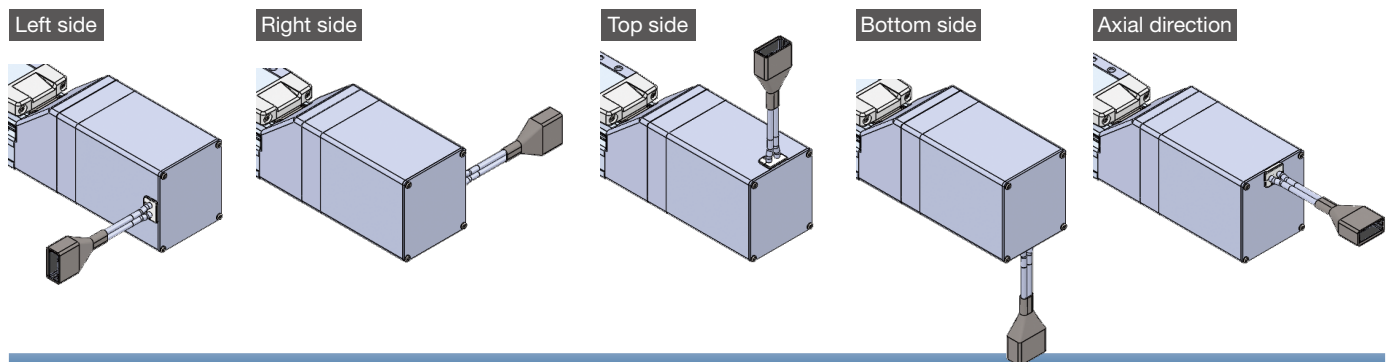

Restart from the last stop position is possible.

Easy operation restart after recovery of the power supply

The position information is held by the encoder even when the power supply is turned off. A return to origin operation is not necessary when the power supply is recovered.



Does not require the use of batteries.

Reduced maintenance

Batteries are not used to store the position information. Therefore, there is no need to store spare batteries or replace dead batteries.

Detection of table stop position by means of an auto switch is possible. p. 29, 40

For the slider type

Allows for position detection of the table throughout the stroke



For the rod type

For checking the limit and the intermediate signal





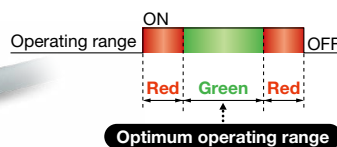

2-color indicator solid state auto switch (D-M9□ series)

Accurate setting of the mounting position can be performed without mistakes.

A green light lights up when within the optimum operating range.





Variations

Type	Slider Type		Rod Type	Guide Rod Type
Series	LE2FS□H  p. 6	LE2FB□H  p. 30	LE2Y□H  p. 42	LE2YG□H  p. 62
Actuation type	In-line: Ball screw Parallel: Ball screw + Belt		Belt	In-line: Ball screw Parallel: Ball screw + Belt
Max. speed*1 [mm/s]	1200		1700	900
Positioning repeatability [mm]	±0.015 (Lead H for size 25/32/40: ±0.02)		±0.08	±0.02
Drive motor	Battery-less absolute (Step motor 24 VDC) ●		●	●
Power supply	24 VDC ±10%			
Operation mode	Positioning operation Pushing			
Size	16	●	●	●
	25	●	●	●
	32	●	●	●
	40	●	—	—
Max. work load [kg] The values in parentheses are for when mounted vertically.	16	18 (12)	1	40 (10)
	25	40 (15)	10	70 (30)
	32	68 (20)	19	100 (46)
	40	80 (40)	—	—
Max. pushing force [N]	16	154	—	154
	25	511	—	511
	32	796	—	796
	40	637	—	—
Max. stroke [mm]	1200		2600	500
Auto switch mounting	●		●*2	●

*1 The numerical values vary depending on the actuator type, work load, speed, and specifications. Please contact SMC for further details.

*2 Excludes size 16

Type	New Slide Tables	
Series	LE2S□H  p. 84	LE2SH□H  p. 84
Actuation type	Slide screw + Belt (R/L type), Slide screw (D type)	
Max. speed [mm/s]	550	450
Positioning repeatability [mm]	Basic type ±0.05	
Drive motor	Battery-less absolute (Step motor 24 VDC) ●	
Power supply	24 VDC ±10%	
Size	16	●
	25	●
Max. work load [kg] The values in parentheses are for when mounted vertically.	16	3 (3) 8 (2)
	25	5 (5) 12 (4)
Max. pushing force [N]	16	84 84
	25	189 189
Max. stroke [mm]	150	

Type	Rotary Table		
Series	LE2R□H  p. 122		
Actuation type	Special worm gear + Belt drive		
Rotation angle [°]	320 180, 90 (With external stopper)		
Positioning repeatability [°]	Basic type	±0.05	
	High-precision type	±0.03	
Drive motor	Battery-less absolute (Step motor 24 VDC) ●		
Power supply	24 VDC ±10%		
Size	30	●	
	50	●	
Max. rotating torque [N·m]	30	High torque	2.5
		Basic	1.7
	50	High torque	13.9
		Basic	8.7
Max. pushing torque [N·m]	30	High torque	2.5
		Basic	1.7
	50	High torque	6.9
		Basic	4.3

Electric Actuators Slider Type/Rod Type/Guide Rod Type/Slide Tables/Rotary Table

LE2F□□H/LE2Y(G)□□H/LE2S(H)□□H/LE2R□□H Series

Battery-less Absolute (Step Motor 24 VDC)

System Construction

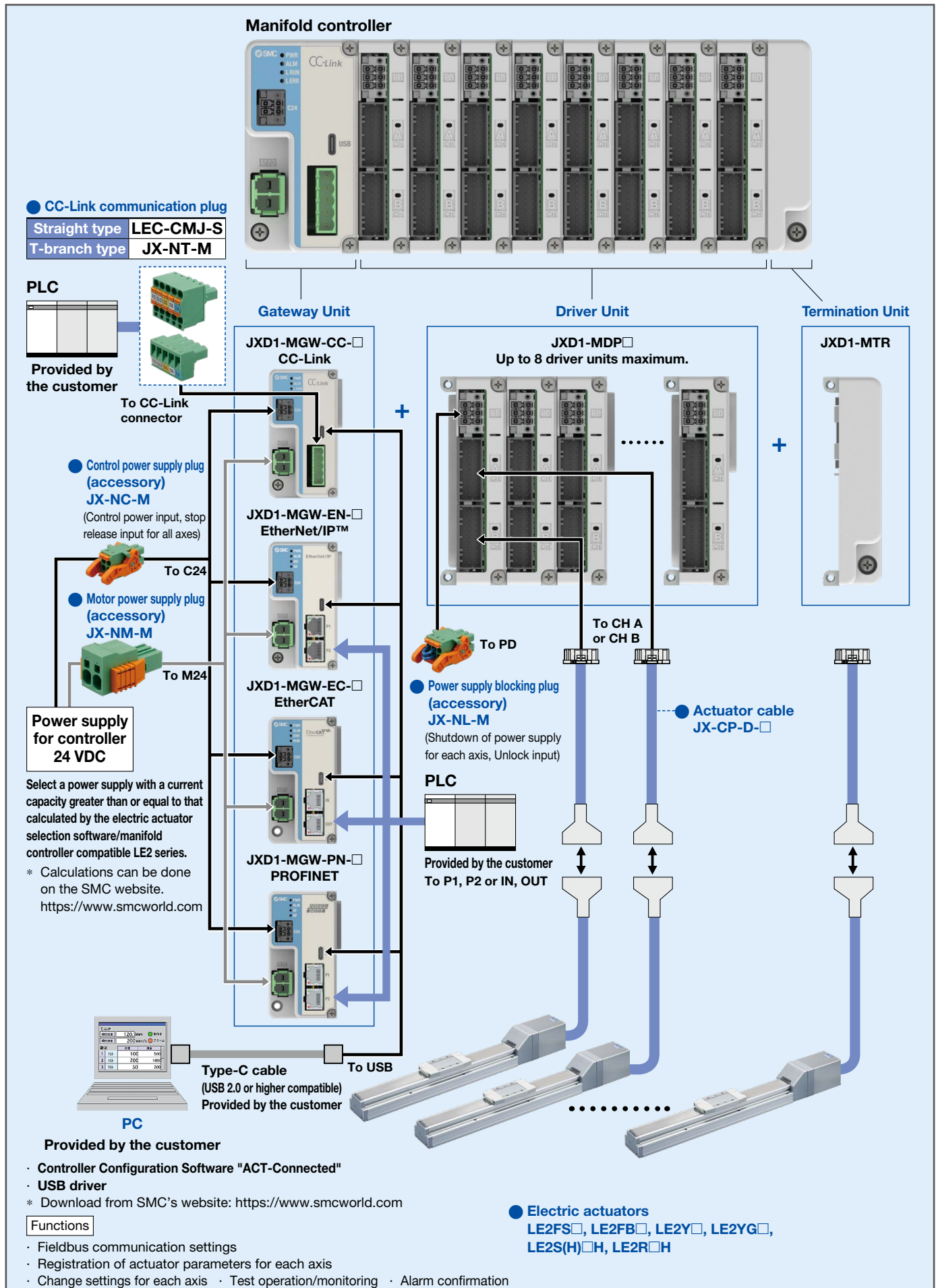

CONTENTS

Compatible with Manifold Controller

Electric Actuators

Slider Type/Ball Screw Drive LE2FS□H Series **p. 6**

Battery-less Absolute (Step Motor 24 VDC)



Model Selection	p. 7
How to Order	p. 18
Specifications	p. 19
Dimensions	p. 21

Slider Type/Belt Drive LE2FB□H Series **p. 30**

Battery-less Absolute (Step Motor 24 VDC)



Model Selection	p. 31
How to Order	p. 34
Specifications	p. 35
Dimensions	p. 37

Rod Type LE2Y□H Series **p. 42**

Battery-less Absolute (Step Motor 24 VDC)



Model Selection	p. 43
How to Order	p. 50
Specifications	p. 51
Dimensions	p. 53

Guide Rod Type LE2YG□H Series **p. 62**

Battery-less Absolute (Step Motor 24 VDC)



Model Selection	p. 63
How to Order	p. 73
Specifications	p. 74
Dimensions	p. 76

CONTENTS

Compatible with Manifold Controller

Electric Actuators

Slide Table/Compact Type LE2S□H Series **p. 84**

Battery-less Absolute (Step Motor 24 VDC)



Model Selection	p. 85
How to Order	p. 94
Specifications	p. 95
Dimensions	p. 96

Slide Table/High Rigidity Type LE2SH□H Series **p. 84**

Battery-less Absolute (Step Motor 24 VDC)



Model Selection	p. 103
How to Order	p. 112
Specifications	p. 113
Dimensions	p. 114

Rotary Table LE2R□H Series **p. 122**

Battery-less Absolute (Step Motor 24 VDC)



Model Selection	p. 123
How to Order	p. 127
Specifications	p. 128
Dimensions	p. 129

Auto Switch Mounting p. 29, 40, 61

Solid State Auto Switch, Normally Closed Solid State Auto Switch, 2-Color Indicator Solid State Auto Switch p. 131

Slider Type/Ball Screw Drive

LE2FS□H Series

p. 7

Battery-less Absolute (Step Motor 24 VDC)

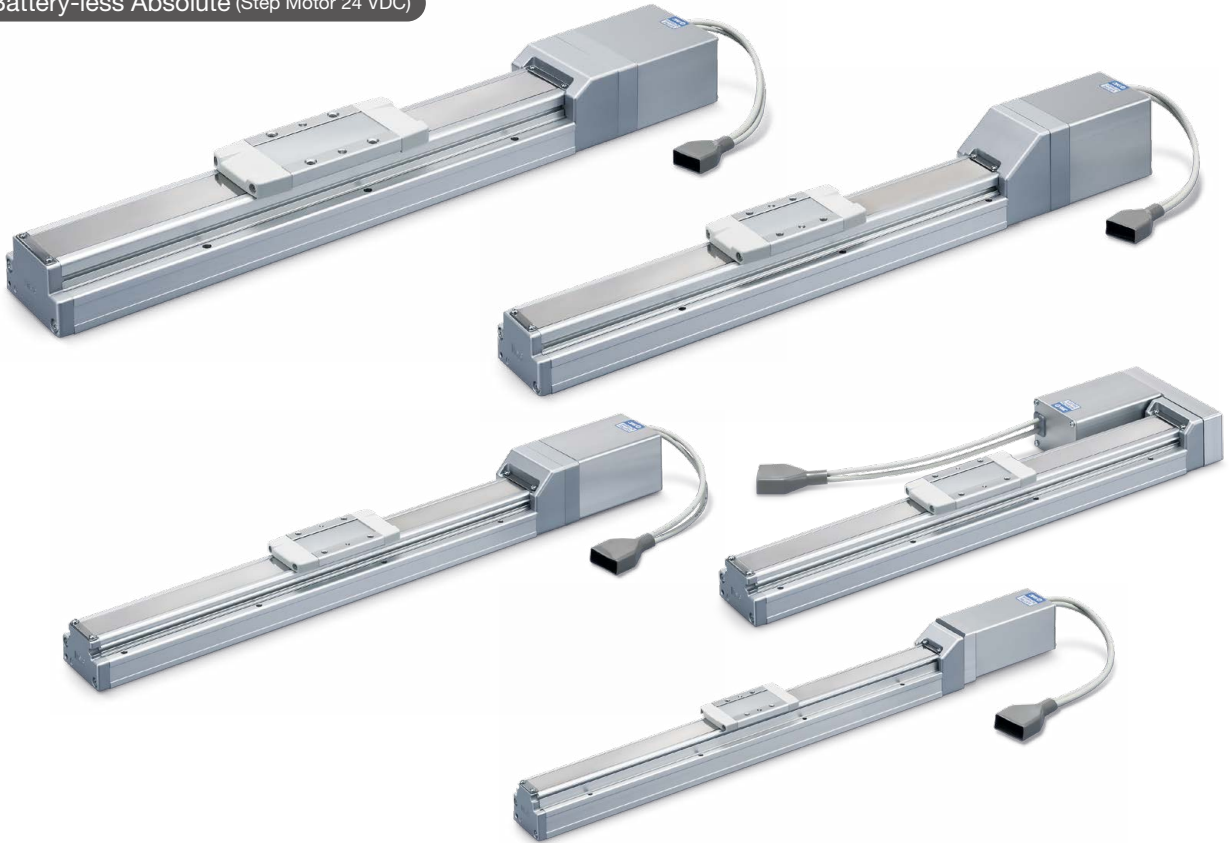

Model Selection

LE2FS□H

LE2FB□H

LE2Y□H

LE2YG□H

LE2S(H)□H

LE2R□H

Auto Switch

Model Selection



Selection Procedure



Selection Example

Operating conditions

- Workpiece mass: 10 [kg]
- Speed: 300 [mm/s]
- Acceleration/Deceleration: 10000 [mm/s²]
- Stroke: 200 [mm]
- Mounting orientation: Horizontal upward
- Workpiece mounting condition:

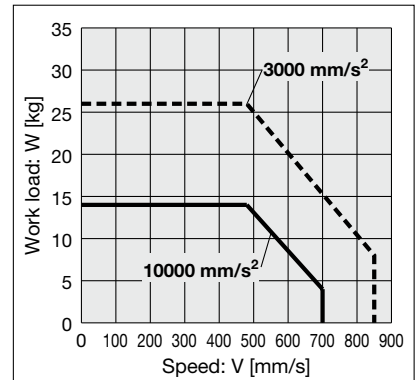
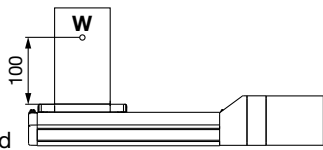

<Speed-Work load graph>
(LE2FS25H/Battery-less absolute)

Step 1 Check the work load-speed. <Speed-Work load graph> (pages 10 to 13)
Select a model based on the workpiece mass and speed while referencing the speed-work load graph.

Selection example) The **LE2FS25D□HA-200** can be temporarily selected as a possible candidate based on the graph shown on the right side.

Step 2 Check the cycle time.

Calculate the **cycle time** using the following calculation method.

Cycle time:

T can be found from the following equation.

$$T = T1 + T2 + T3 + T4 \text{ [s]}$$

- T1: Acceleration time and T3: Deceleration time can be found by the following equation.

$$T1 = V/a1 \text{ [s]} \quad T3 = V/a2 \text{ [s]}$$

- T2: Constant speed time can be found from the following equation.

$$T2 = \frac{L - 0.5 \cdot V \cdot (T1 + T3)}{V} \text{ [s]}$$

- T4: Settling time varies depending on the conditions such as actuator types, load, and in position of the step data. Reference value for settling time: 0.15 s or less. The following value is used for this calculation.

$$T4 = 0.15 \text{ [s]}$$

Calculation example)

T1 to T4 can be calculated as follows.

$$T1 = V/a1 = 300/10000 = 0.03 \text{ [s]}$$

$$T3 = V/a2 = 300/10000 = 0.03 \text{ [s]}$$

$$T2 = \frac{L - 0.5 \cdot V \cdot (T1 + T3)}{V} = \frac{200 - 0.5 \cdot 300 \cdot (0.03 + 0.03)}{300} = 0.64 \text{ [s]}$$

$$T4 = 0.15 \text{ [s]}$$

The **cycle time** can be found as follows.

$$T = T1 + T2 + T3 + T4 = 0.03 + 0.64 + 0.03 + 0.15 = 0.85 \text{ [s]}$$

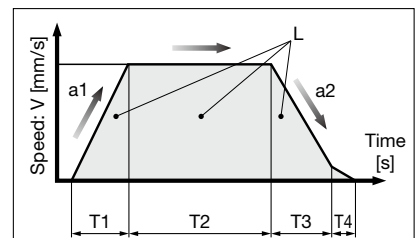

- L : Stroke [mm] ... (Operating condition)
- V : Speed [mm/s] ... (Operating condition)
- a1: Acceleration [mm/s²] ... (Operating condition)
- a2: Deceleration [mm/s²] ... (Operating condition)

- T1: Acceleration time [s]
Time until reaching the set speed
- T2: Constant speed time [s]
Time while the actuator is operating at a constant speed
- T3: Deceleration time [s]
Time from the beginning of the constant speed operation to stop
- T4: Settling time [s]
Time until positioning is completed

Step 3 Check the allowable moment. <Static allowable moment> (page 13) <Dynamic allowable moment> (pages 14, 15)

Confirm the moment that applies to the actuator is within the allowable range for both static and dynamic conditions.

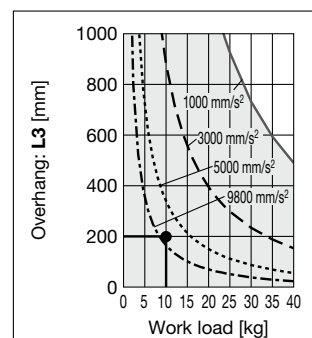
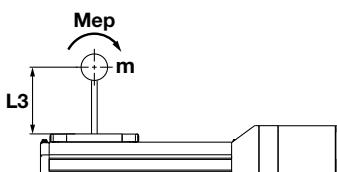

Based on the above calculation result, the **LE2FS25D□HA-200** should be selected.

Selection Procedure

Pushing Control Selection Procedure



* The duty ratio is a ratio of the operation time in one cycle.

Selection Example

Operating conditions

- Mounting condition: Horizontal (pushing)
- Attachment height: 50 [mm]
- Pushing force: 40 [N]
- Duty ratio: 15 [%]
- Speed: 100 [mm/s]
- Stroke: 200 [mm]

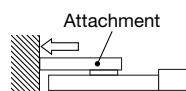

Step 1 Check the duty ratio.

<Conversion table of pushing force–duty ratio>

Select the [Pushing force] from the duty ratio while referencing the conversion table of pushing force–duty ratio.

Selection example)

Based on the table below,

- Duty ratio: 100 [%]

The pushing force set value will be 45 [%].

<Conversion table of pushing force–duty ratio>

(LE2FS16H/Battery-less absolute)

Ambient temperature	Pushing force set value [%]	Duty ratio [%]	Continuous pushing time [min]
40°C or less	45 or less	100	No restriction

* [Pushing force set value] is one of the step data input to the controller.

* [Continuous pushing time] is the time that the actuator can continuously keep pushing.

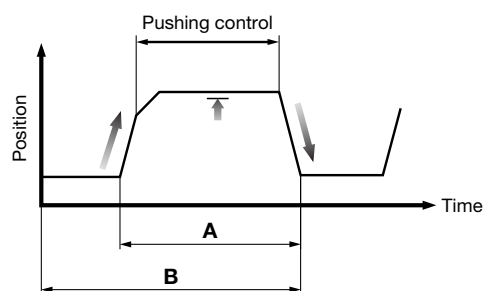

$$\text{Duty ratio} = A/B \times 100 [\%]$$

Step 2 Check the pushing force.

<Force conversion graph>

Select a model based on the pushing force set value and force while referencing the force conversion graph.

Selection example)

Based on the graph shown on the right side,

- Pushing force: 40 [N]
- Pushing force set value: 39 [%]

The **LE2FS16HA** can be temporarily selected as a possible candidate.

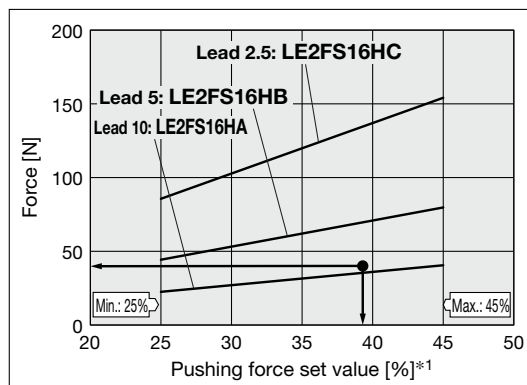

<Force conversion graph> (LE2FS16□H/Step motor)

*1 Set values for the controller

Step 3 Check the dynamic allowable moment during a pushing operation.

<Static allowable moment> (page 13)

<Dynamic allowable moment> (page 9)

Confirm the moment that applies to the actuator is within the allowable range for both static and dynamic conditions.

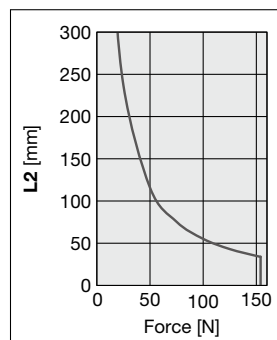
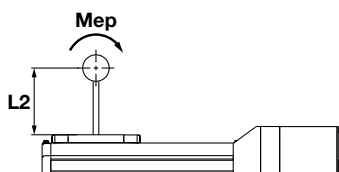

Based on the above calculation result, the **LE2FS16HA-200** should be selected.

Dynamic Allowable Moment for Pushing

* These graphs show the amount of allowable overhang (guide unit) when the pushing force application position overhangs in one direction.

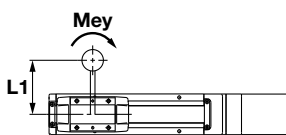
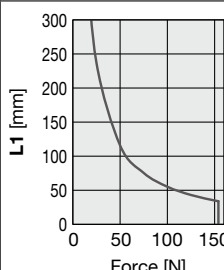
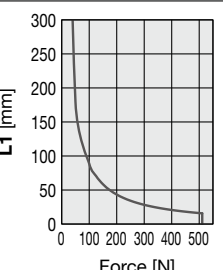
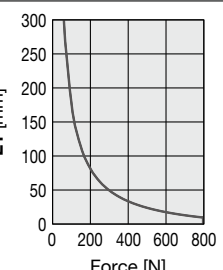
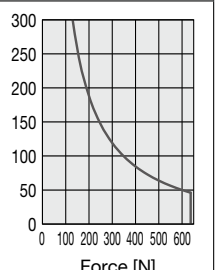
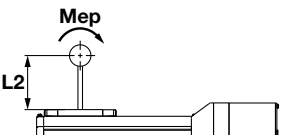
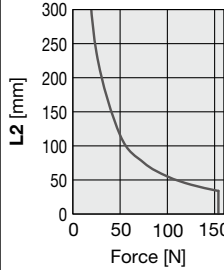
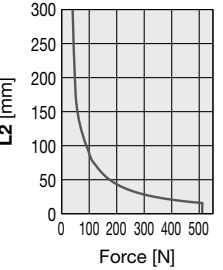
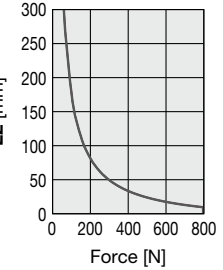
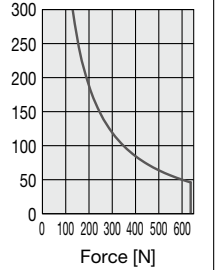
Orientation	Load overhanging direction F: Force Me: Allowable moment [N·m] L: Position of pushing force application [mm]	Model			
		LE2FS16	LE2FS25	LE2FS32	LE2FS40
Horizontal/Bottom/Wall/Vertical	 Y				
	 Z				

Calculation of Guide Load Factor

1. Decide operating conditions.

Model: LE2FS□H

The position applied the pushing force [mm]: **Yc/Zc**

Size: 16/25/32/40

Pushing force: **F**

2. Select the target graph while referencing the model, size, and mounting orientation.

3. Based on the acceleration and work load, find the overhang [mm]: **Ly/Lz** from the graph.

4. Calculate the load factor for each direction.

$$\alpha_y = Y_c/L_y, \alpha_z = Z_c/L_z$$

5. Confirm the total of α_y and α_z is 1 or less.

$$\alpha_y + \alpha_z \leq 1$$

When 1 is exceeded, consider changing the pushing force application position or the pushing force.

Example

1. Operating conditions

Model: LE2FS40H

Size: 40

Pushing force [N]: **100**

Position of pushing force application [mm]: **Yc = 100, Zc = 100**

2. Determine the **fw = 1.5**

3. **Ly = 300 mm, Lz = 300 mm**

4. The load factor for each direction can be found as follows.

$$\alpha_y = 100/300 = 0.33$$

$$\alpha_z = 100/300 = 0.33$$

5. **$\alpha_y + \alpha_z = 0.66 \leq 1$**

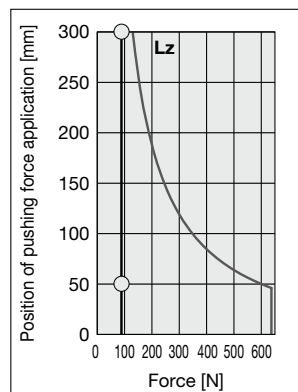
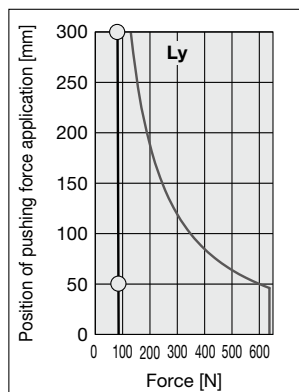

* When the product repeatedly cycles with partial strokes, operate it at a full stroke at least once every few dozen cycles.

Speed-Work Load Graph (Guide)

LE2FS16/Ball Screw Drive

Horizontal/Lead 10

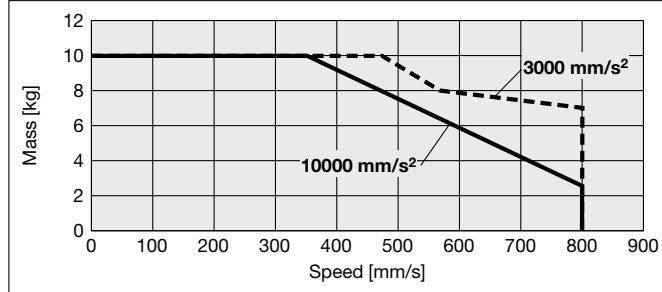

Vertical/Lead 10

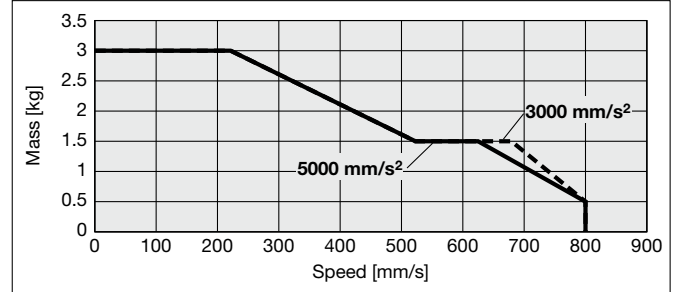

LE2FS16/Ball Screw Drive

Horizontal/Lead 5

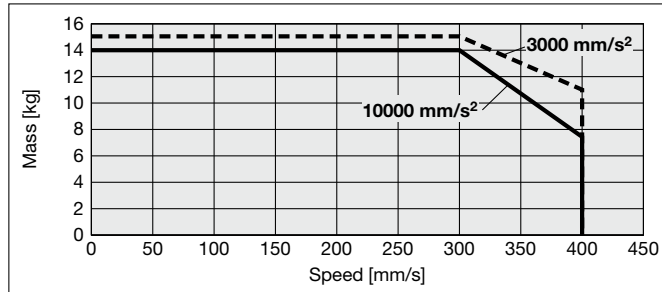

Vertical/Lead 5

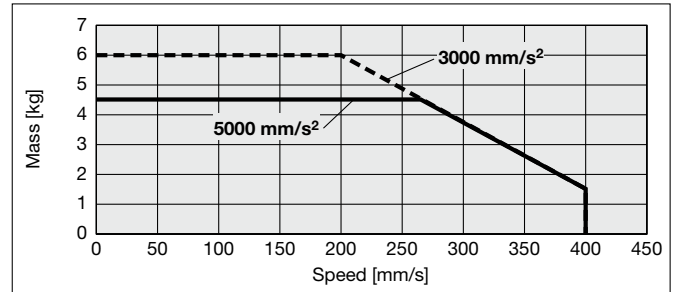

LE2FS16/Ball Screw Drive

Horizontal/Lead 2.5

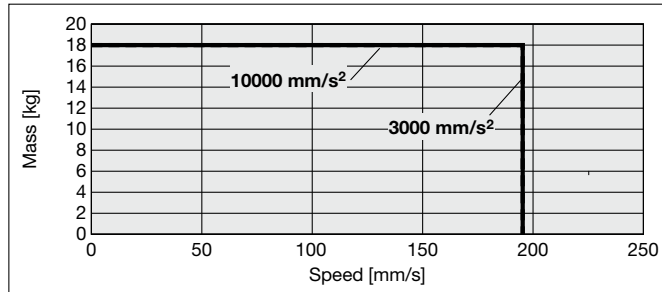

Vertical/Lead 2.5

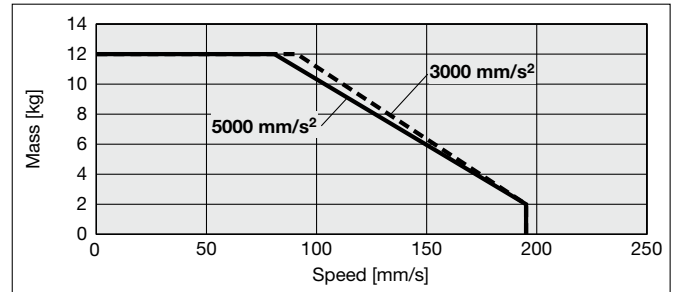

Model Selection

LE2FS□H

LE2FB□H

LE2Y□H

LE2YG□H

LE2S(H)□H

LE2R□H

Auto Switch

Speed-Work Load Graph (Guide)

LE2FS25/Ball Screw Drive

Horizontal/Lead 20

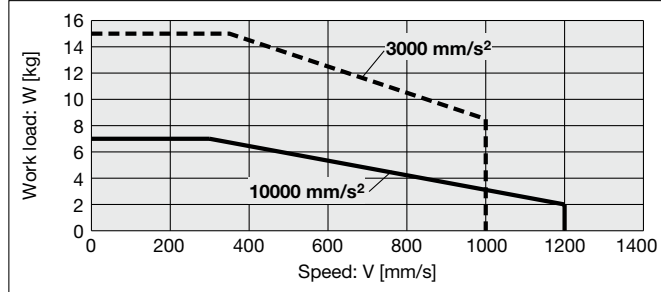

Vertical/Lead 20

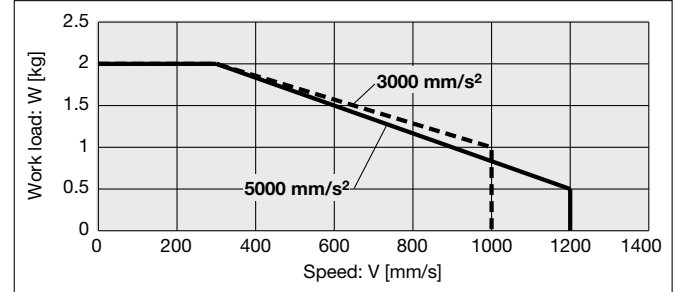

LE2FS25/Ball Screw Drive

Horizontal/Lead 12

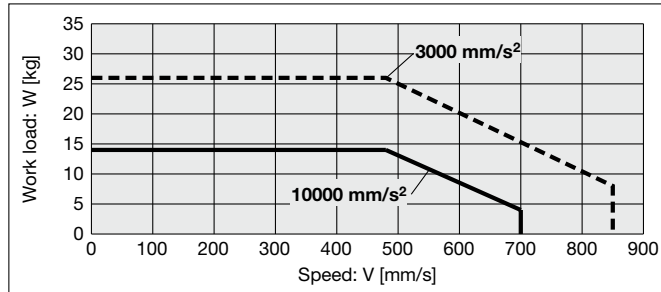

Vertical/Lead 12

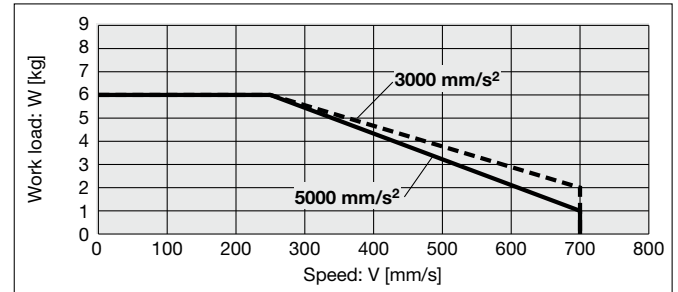

LE2FS25/Ball Screw Drive

Horizontal/Lead 6

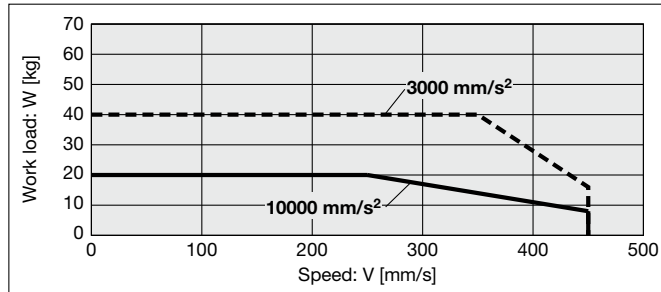

Vertical/Lead 6

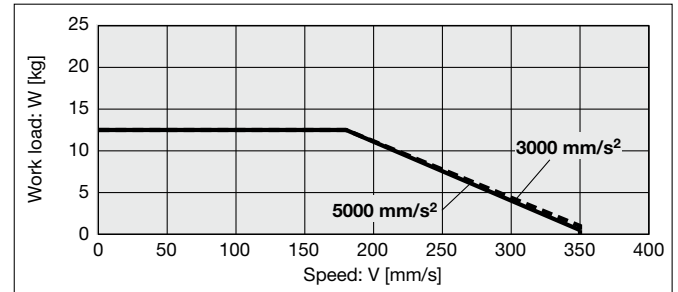

LE2FS25/Ball Screw Drive

Horizontal/Lead 3

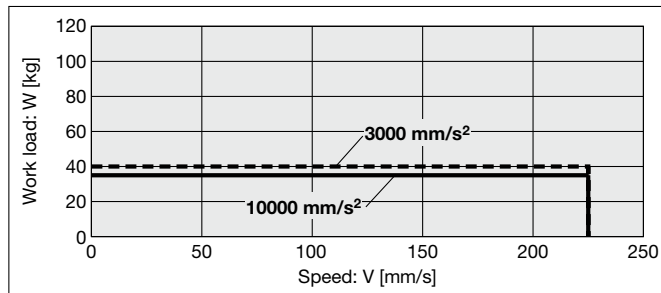

Vertical/Lead 3

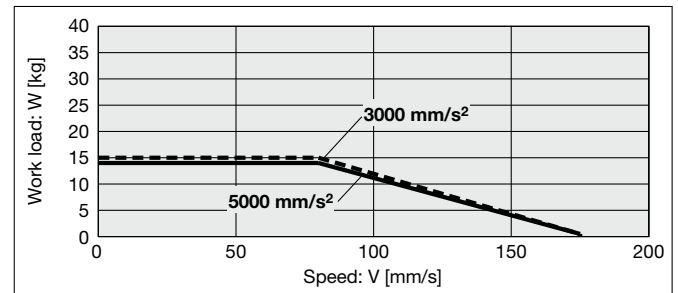

Speed-Work Load Graph (Guide)

LE2FS32/Ball Screw Drive

Horizontal/Lead 24

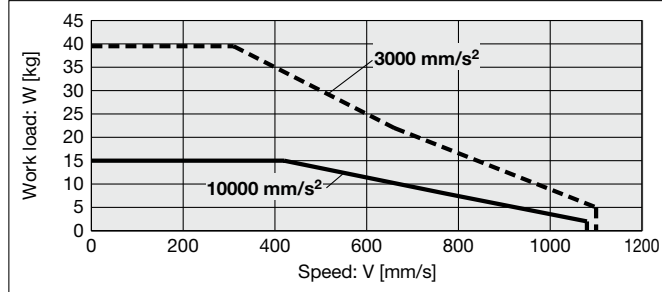

Vertical/Lead 24

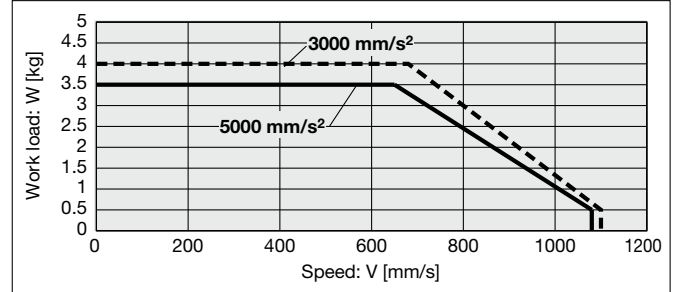

LE2FS32/Ball Screw Drive

Horizontal/Lead 16

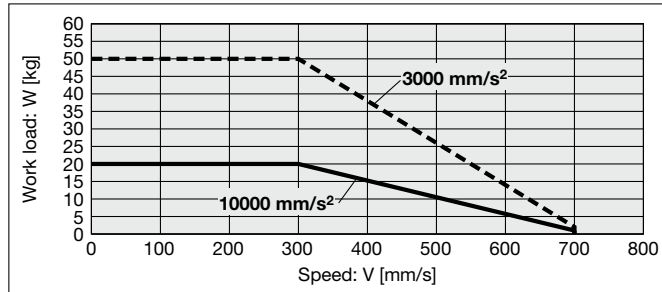

Vertical/Lead 16

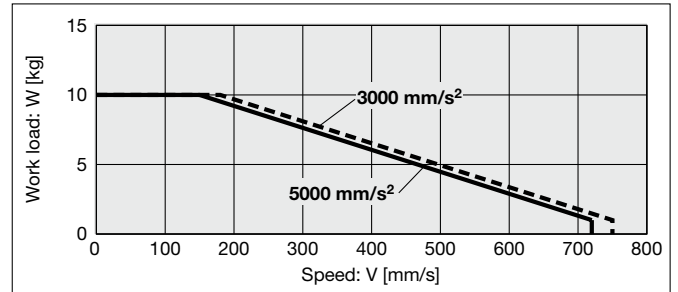

LE2FS32/Ball Screw Drive

Horizontal/Lead 8

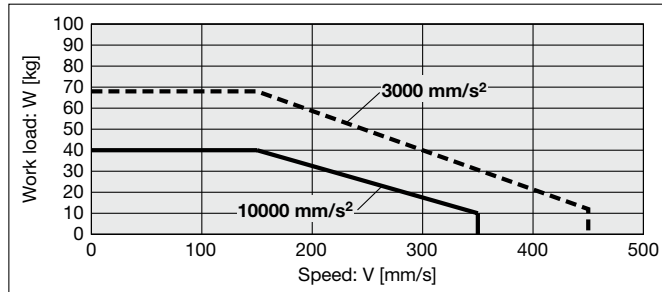

Vertical/Lead 8

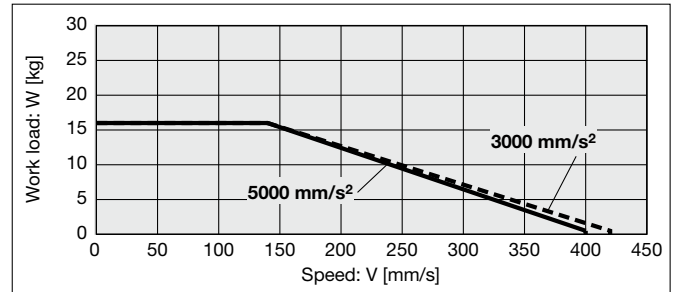

LE2FS32/Ball Screw Drive

Horizontal/Lead 4

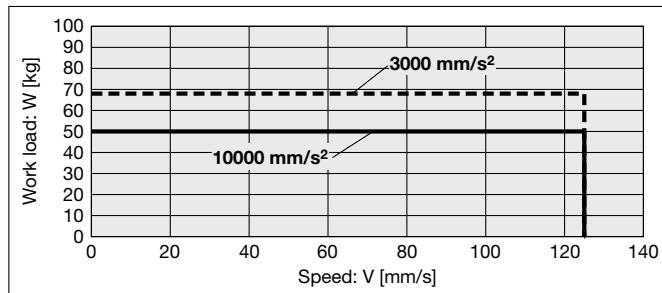

Vertical/Lead 4

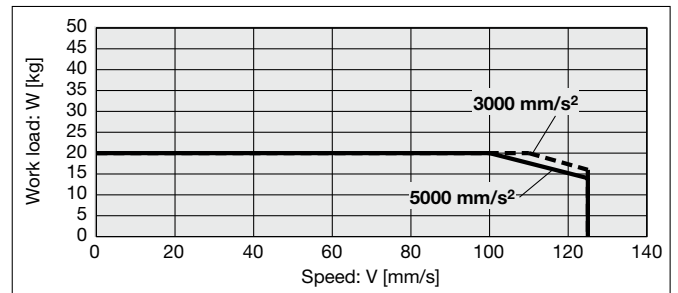

Model Selection

LE2FS□H

LE2FB□H

LE2Y□H

LE2YG□H

LE2S(H)□H

LE2R□H

Auto Switch

Speed-Work Load Graph (Guide)

LE2FS40/Ball Screw Drive

Horizontal/Lead 30

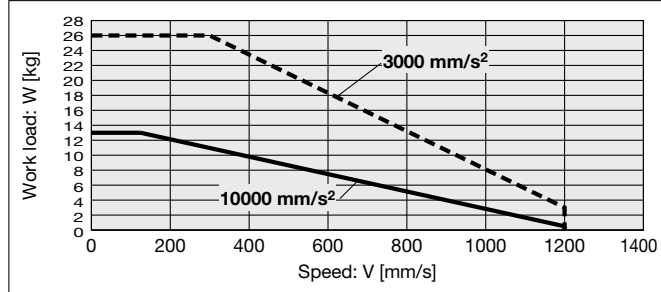

Vertical/Lead 30

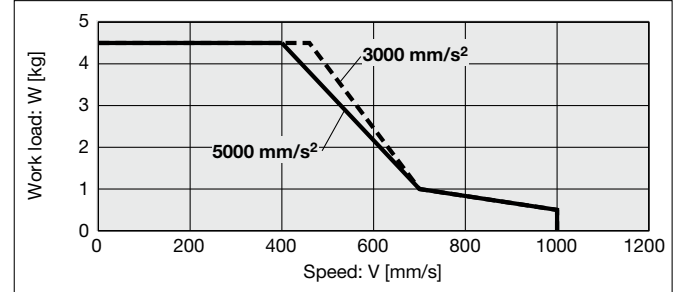

LE2FS40/Ball Screw Drive

Horizontal/Lead 20

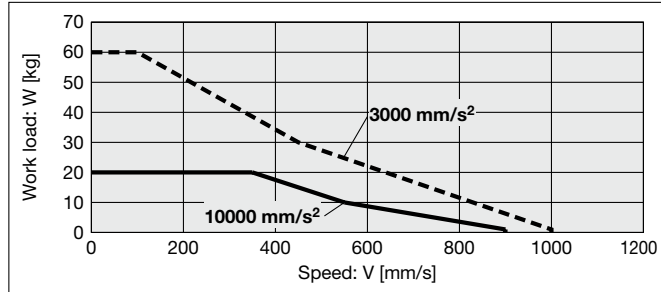

Vertical/Lead 20

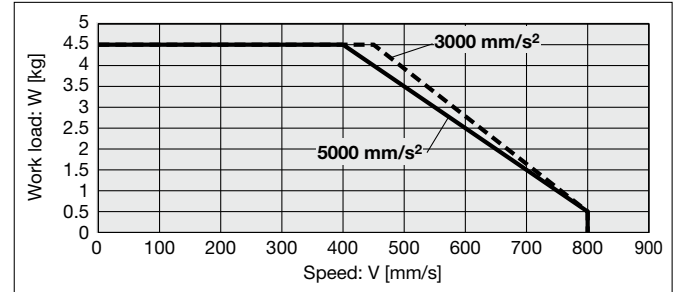

LE2FS40/Ball Screw Drive

Horizontal/Lead 10

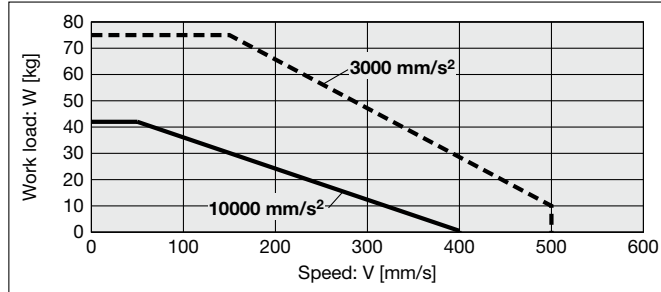

Vertical/Lead 10

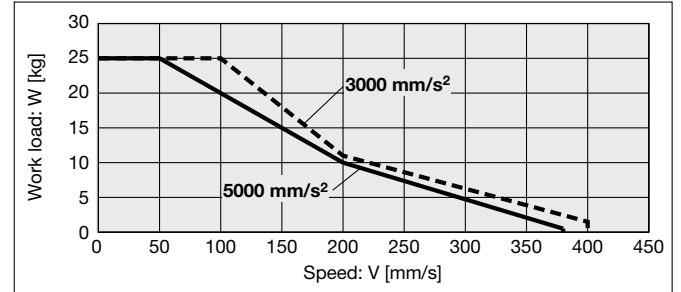

LE2FS40/Ball Screw Drive

Horizontal/Lead 5

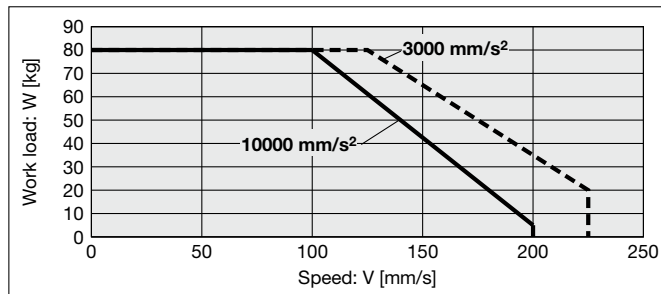

Vertical/Lead 5

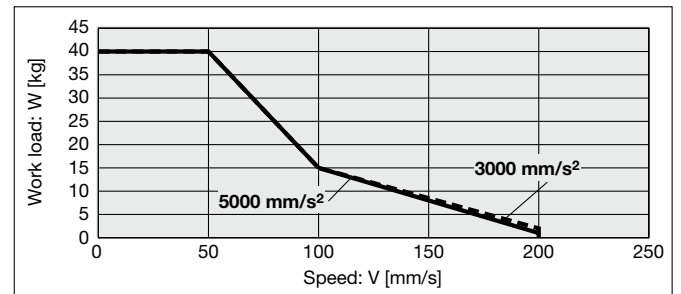

Static Allowable Moment*1

					[N·m]
Model	Size	Pitching	Yawing	Rolling	
LE2FS□H	16	10.0	10.0	20.0	
	25	27.0	27.0	52.0	
	32	46.0	46.0	101.0	
	40	110.0	110.0	207.0	

*1 The static allowable moment is the amount of static moment which can be applied to the actuator when it is stopped.
If the product is exposed to impact or repeated load, be sure to take adequate safety measures when using the product.

Dynamic Allowable Moment

* These graphs show the amount of allowable overhang (guide unit) when the center of gravity of the workpiece overhangs in one direction.

Acceleration ——— 1000 mm/s² - - - 3000 mm/s² ······ 5000 mm/s² - - - - 10000 mm/s²

Orientation	Load overhanging direction m : Work load [kg] Me: Allowable moment [N·m] L : Overhang to the work load center of gravity [mm]	Model			
		LE2FS16H	LE2FS25H	LE2FS32H	LE2FS40H
Horizontal/Bottom	 X L1 [mm]				
	 Y L2 [mm]				
	 Z L3 [mm]				
Wall	 X L4 [mm]				
	 Y L5 [mm]				
	 Z L6 [mm]				

Model Selection

LE2FS□H

LE2FB□H

LE2Y□H

LE2YG□H

LE2S(H)□H

LE2R□H

Auto Switch

Dynamic Allowable Moment

* These graphs show the amount of allowable overhang (guide unit) when the center of gravity of the workpiece overhangs in one direction.

Acceleration ——— 1000 mm/s² - - - 3000 mm/s² 5000 mm/s²

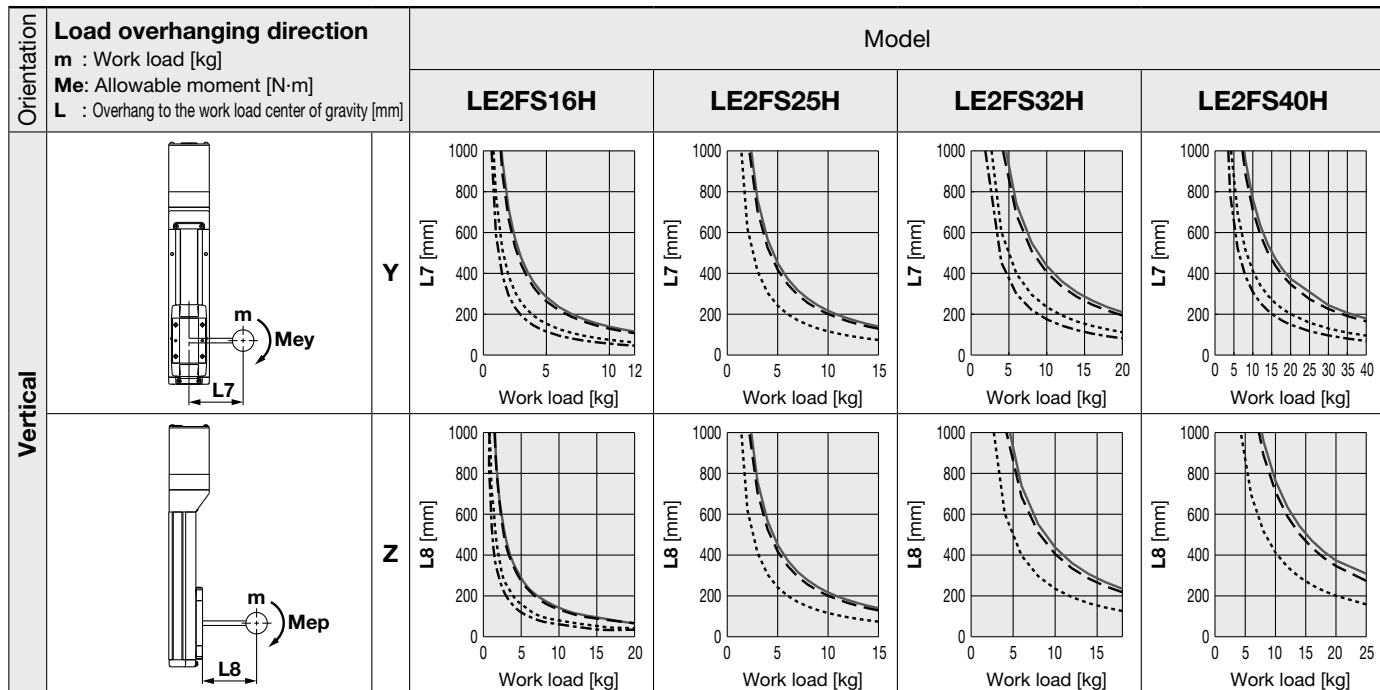

Calculation of Guide Load Factor

1. Decide operating conditions.

Model: LE2FS□H

Size: 16/25/32/40

Mounting orientation: Horizontal/Bottom/Wall/Vertical

Acceleration [mm/s²]: a

Work load [kg]: m

Work load center position [mm]: Xc/Yc/Zc

2. Select the target graph while referencing the model, size, and mounting orientation.

3. Based on the acceleration and work load, find the overhang [mm]: Lx/Ly/Lz from the graph.

4. Calculate the load factor for each direction.

$$\alpha_x = X_c/L_x, \alpha_y = Y_c/L_y, \alpha_z = Z_c/L_z$$

5. Confirm the total of α_x , α_y , and α_z is 1 or less.

$$\alpha_x + \alpha_y + \alpha_z \leq 1$$

When 1 is exceeded, please consider a reduction of acceleration and work load, or a change of the work load center position and series.

Mounting orientation

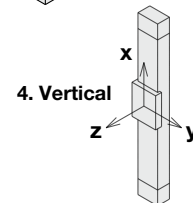
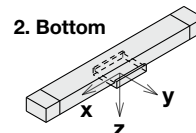
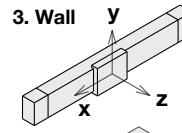
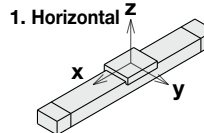

Example

1. Operating conditions

Model: LE2FS40H

Size: 40

Mounting orientation: Horizontal

Acceleration [mm/s²]: 3000

Work load [kg]: 20

Work load center position [mm]: Xc = 0, Yc = 50, Zc = 200

2. Select the graphs for horizontal of the LE2FS40H on page 14.

3. Lx = 350 mm, Ly = 250 mm, Lz = 1000 mm

4. The load factor for each direction can be found as follows.

$$\alpha_x = 0/350 = 0$$

$$\alpha_y = 50/250 = 0.2$$

$$\alpha_z = 200/1000 = 0.2$$

5. $\alpha_x + \alpha_y + \alpha_z = 0.4 \leq 1$

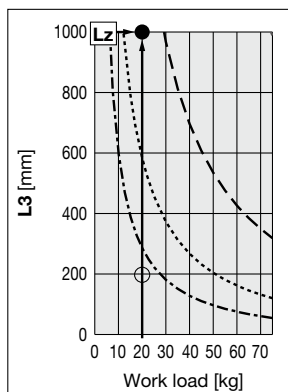
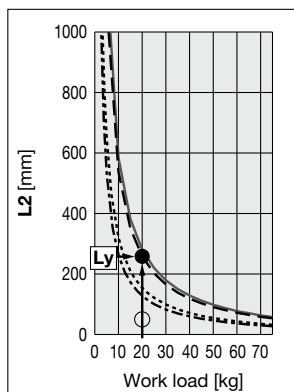
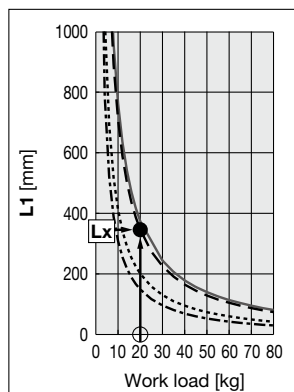
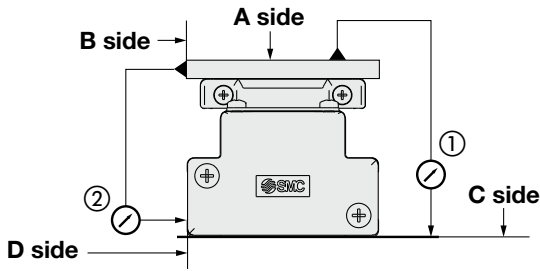

Table Accuracy (Reference Value)



Model	Traveling parallelism [mm] (Every 300 mm)	
	① C side traveling parallelism to A side	② D side traveling parallelism to B side
LE2FS16H	0.05	0.03
LE2FS25H	0.05	0.03
LE2FS32H	0.05	0.03
LE2FS40H	0.05	0.03

* Traveling parallelism does not include the mounting surface accuracy. (Excludes when the stroke exceeds 2000 mm)

Table Displacement (Reference Value)

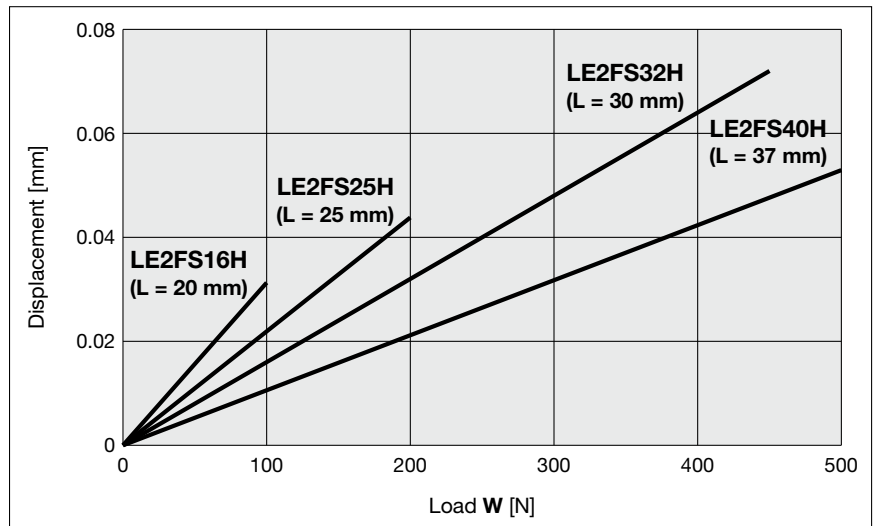
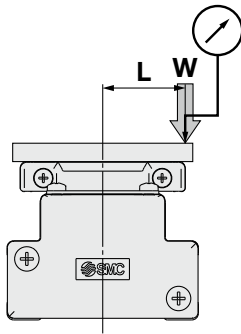

* This displacement is measured when a 15 mm aluminum plate is mounted and fixed on the table.
* Check the clearance and play of the guide separately.

Overhang Displacement Due to Table Clearance (Initial Reference Value)

Basic type

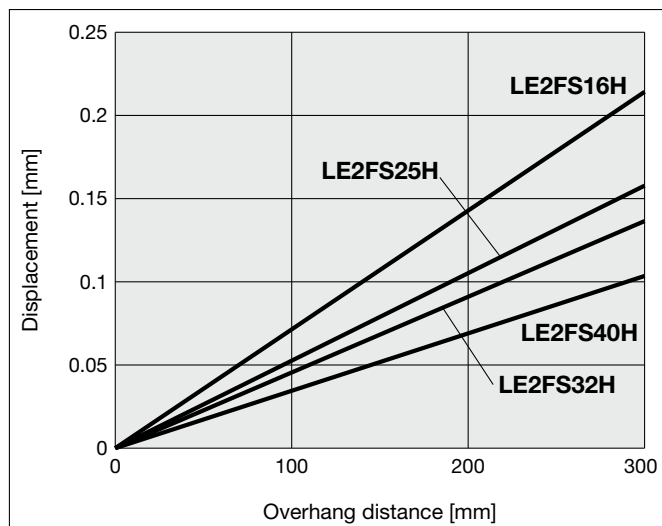

High-precision type

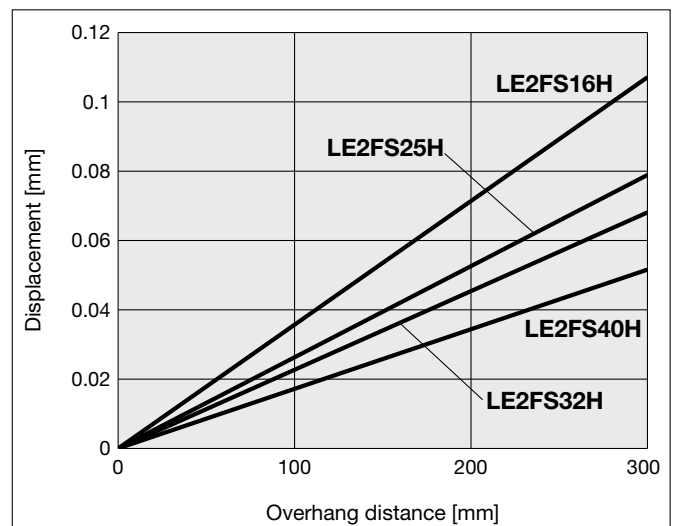

Force Conversion Graph (Guide)

LE2FS16□H

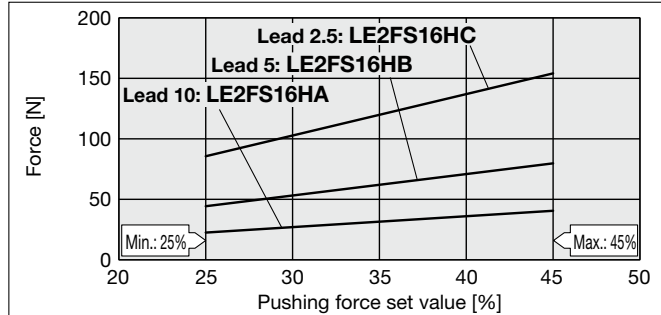

Ambient temperature	Pushing force set value [%]	Duty ratio [%]	Continuous pushing time [min]
40°C or less	45 or less	100	No restriction

LE2FS25□H

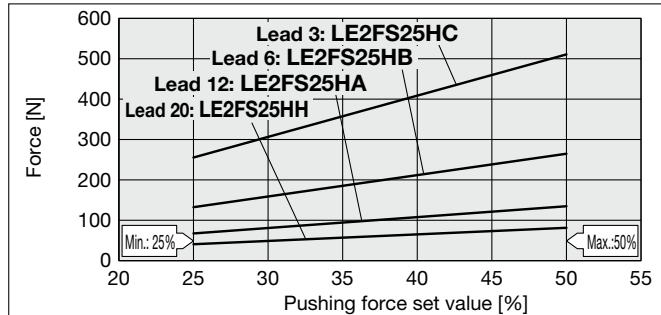

Ambient temperature	Pushing force set value [%]	Duty ratio [%]	Continuous pushing time [min]
40°C or less	50 or less	100	No restriction

LE2FS32□H

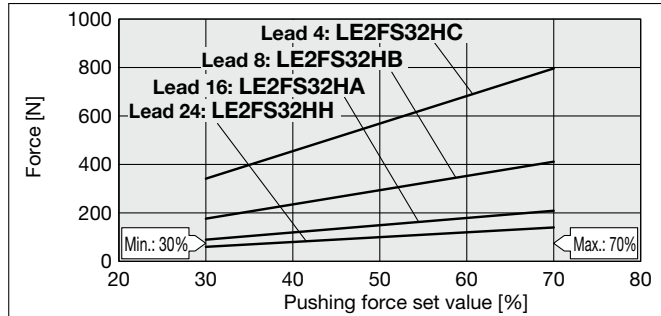

Ambient temperature	Pushing force set value [%]	Duty ratio [%]	Continuous pushing time [min]
40°C or less	70 or less	100	No restriction

LE2FS40□H

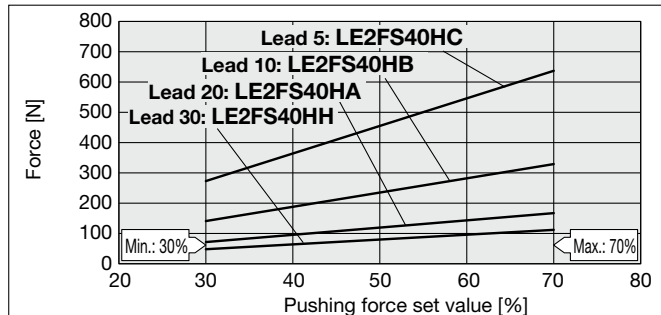

Ambient temperature	Pushing force set value [%]	Duty ratio [%]	Continuous pushing time [min]
40°C or less	70 or less	100	No restriction

<Limit Values for Pushing Force and Trigger Level in Relation to Pushing Speed>

Model	Lead	Pushing speed [mm/s]	Pushing force (Setting input value)
LE2FS16□H	A/B/C	26 to 50	30 to 45%

There is a limit to the pushing force in relation to the pushing speed. If the product is operated outside of the range (low pushing force), the completion signal [INP] may be output before the pushing operation has been completed (during the moving operation).
If operating with the pushing speed below the min. speed, please check for operating problems before using the product.

<Set Values for Vertical Upward Transfer Pushing Operations>

For vertical loads (upward), set the pushing force to the max. value shown below and operate at the work load or less.

Model	LE2FS16□H			LE2FS25□H			LE2FS32□H			LE2FS40□H					
	A	B	C	H	A	B	C	H	A	B	C	H	A	B	C
Work load [kg]	1	1.5	3	1	2.5	5	10	2	4.5	9	18	1.5	3	7	14
Pushing force	45%			50%			70%			70%					

Battery-less Absolute (Step Motor 24 VDC)

Compatible with Manifold Controller

Slider Type/Ball Screw Drive

LE2FS□H Series LE2FS16, 25, 32, 40

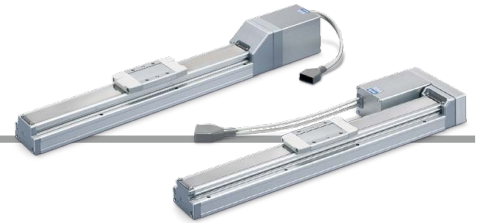

How to Order

LE2FS **32** **R** **1** **H** **A** - **300** **A** **G**

① ② ③ ④ ⑤ ⑥ ⑦ ⑧

① Size

16
25
32
40

② Motor mounting position

D	In-line
R	Right side parallel
L	Left side parallel

③ Motor cable entry direction

1	Axial
2	Right
3	Left
4	Top
5	Bottom

④ Motor type

Symbol	Type	Compatible controller
H	Battery-less absolute (Step motor 24 VDC)	JXD1

⑤ Lead [mm]

Symbol	LE2FS16	LE2FS25	LE2FS32	LE2FS40
H	—	20	24	30
A	10	12	16	20
B	5	6	8	10
C	2.5	3	4	5

⑥ Stroke

50	50
to	to
1200	1200

* For details, refer to the applicable stroke table below.

⑦ Motor option

A	Without option
B	With lock

⑧ Grease application (Seal band part)

G	With
N	Without (Roller specification)

The auto switches should be ordered separately. For details, refer to pages 29 and 131 to 133.

Applicable Stroke Table

Size	Stroke																					
	50	100	150	200	250	300	350	400	450	500	550	600	650	700	750	800	850	900	950	1000	1100	1200
16	●	●	●	●	●	●	●	●	●	●	—	—	—	—	—	—	—	—	—	—	—	—
25	●	●	●	●	●	●	●	●	●	●	●	●	●	●	●	●	—	—	—	—	—	—
32	●	●	●	●	●	●	●	●	●	●	●	●	●	●	●	●	●	●	●	●	—	—
40	—	—	●	●	●	●	●	●	●	●	●	●	●	●	●	●	●	●	●	●	●	●

Motor Mounting Position

D: In-line

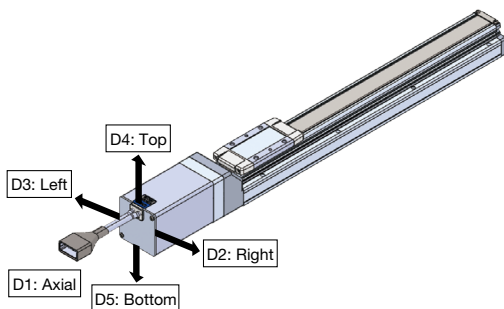

R: Right side parallel

→ R3 is not selectable.

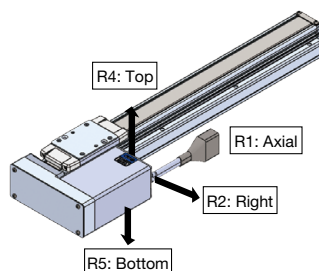

L: Left side parallel

→ L2 is not selectable.

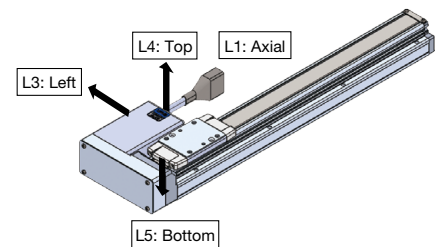

Model Selection

LE2FS□H

LE2FB□H

LE2Y□H

LE2YG□H

LE2S(H)□H

LE2R□H

Auto Switch

Specifications

Model		LE2FS16□H				LE2FS25□H				LE2FS32□H				LE2FS40□H			
Stroke [mm]*1		50 to 500				50 to 800				50 to 1000				150 to 1200			
Work load [kg]*5	Horizontal	10	15	18	15	26	40	40	39.5	50	68	68	26	60	75	80	
	Vertical	3	6	12	2	6	12.5	15	4	10	16	20	4.5	4.5	25	40	
Pushing force [N]**2 *3		23 to 41	44 to 80	86 to 154	41 to 81	67 to 135	132 to 265	255 to 511	60 to 140	90 to 209	176 to 411	341 to 796	48 to 112	72 to 167	141 to 329	273 to 637	
Speed [mm/s]	Stroke range	Up to 400	10 to 800	5 to 400	3 to 195	20 to 1200	12 to 850	6 to 450	3 to 225	24 to 1100	16 to 750	8 to 450	4 to 125	30 to 1200	20 to 1000	10 to 500	5 to 225
		401 to 450	10 to 700	5 to 360	3 to 170	20 to 1100	12 to 750	6 to 400	3 to 225	24 to 1100	16 to 750	8 to 450	4 to 125	30 to 1200	20 to 1000	10 to 500	5 to 225
		401 to 500	10 to 600	5 to 300	3 to 140	20 to 1100	12 to 750	6 to 400	3 to 225	24 to 1100	16 to 750	8 to 450	4 to 125	30 to 1200	20 to 1000	10 to 500	5 to 225
		501 to 600	—	—	—	20 to 900	12 to 540	6 to 270	3 to 135	24 to 1100	16 to 750	8 to 400	4 to 125	30 to 1200	20 to 1000	10 to 500	5 to 225
		601 to 700	—	—	—	20 to 630	12 to 420	6 to 230	3 to 115	24 to 930	16 to 620	8 to 310	4 to 125	30 to 1200	20 to 900	10 to 440	5 to 220
		701 to 800	—	—	—	20 to 550	12 to 330	6 to 180	3 to 90	24 to 750	16 to 500	8 to 250	4 to 125	30 to 1140	20 to 760	10 to 350	5 to 175
		801 to 900	—	—	—	—	—	—	—	24 to 610	16 to 410	8 to 200	4 to 100	30 to 930	20 to 620	10 to 280	5 to 140
		901 to 1000	—	—	—	—	—	—	—	24 to 500	16 to 340	8 to 170	4 to 85	30 to 780	20 to 520	10 to 250	5 to 125
		1001 to 1100	—	—	—	—	—	—	—	—	—	—	—	30 to 660	20 to 440	10 to 220	5 to 110
		1101 to 1200	—	—	—	—	—	—	—	—	—	—	—	30 to 570	20 to 380	10 to 190	5 to 95
Max. acceleration/deceleration [mm/s ²]	Horizontal	10000															
	Vertical	5000															
Pushing speed [mm/s]*4		1 to 50			1 to 35				1 to 30				1 to 30				
Positioning repeatability [mm]		±0.015 (Lead H: ±0.02)															
Lost motion [mm]**6		0.1 or less															
Lead [mm]		10	5	2.5	20	12	6	3	24	16	8	4	30	20	10	5	
Impact/Vibration resistance [m/s ²]*7		50/20															
Actuation type		Ball screw (LE2FS□D□H), Ball screw + Belt (LE2FS□R□H)															
Guide type		Linear guide															
Operating temperature range [°C]		5 to 40															
Operating humidity range [%RH]		90 or less (No condensation)															
Enclosure		IP30															
Electric specifications	Motor size	□28				□42				□56.4							
	Motor type	Battery-less absolute (Step motor 24 VDC)															
	Encoder	Battery-less absolute															
	Power supply voltage [V]	24 VDC ±10%															
Lock unit specifications	Power [W]**8 *10	Max. power 58			Max. power 72				Max. power 93				Max. power 93				
	Type*9	Non-magnetizing lock															
	Holding force [N]	29	59	118	47	78	157	294	72	108	216	421	75	113	225	421	
	Power [W]**10	4			8				8				8				
Power supply voltage [V]		24 VDC ±10%															

*1 Please contact SMC for non-standard strokes as they are produced as special orders.

*2 Pushing force accuracy is ±20% (F.S.).

*3 The pushing force set values for LE2FS16□H are 25% to 45%, for LE2FS25□H are 25% to 50%, for LE2FS32□H are 30% to 70%, and for LE2FS40□H are 30% to 70%. The pushing force values change according to the duty ratio and pushing speed. Check the "Force Conversion Graph" in the catalog.

*4 The allowable speed for pushing operation. When push conveying a workpiece, operate at the vertical work load or less.

*5 The max. work load at 3000 mm/s² acceleration and deceleration speed

Work load varies depending on the speed and acceleration. Check the "Speed-Work Load Graph" in the catalog.

Furthermore, if the cable length exceeds 5 m, the speed and work load specified in the "Speed-Work Load Graph" may decrease by up to 10% for each 5 m increase.

*6 A reference value for correcting errors in reciprocal operation

*7 Impact resistance: No malfunction occurred when the actuator was tested with a drop tester in both an axial direction and a perpendicular direction to the lead screw. (The test was performed with the actuator in the initial state.)

Vibration resistance: No malfunction occurred in a test ranging between 45 to 2000 Hz. The test was performed in both an axial direction and a perpendicular direction to the lead screw. (The test was performed with the actuator in the initial state.)

*8 Indicates the max. power during operation (excluding the controller). This value can be used for the selection of the power supply.

*9 With lock only

*10 For an actuator with lock, add the power for the lock.

Weight

In-line Motor

Series	LE2FS16									
Stroke [mm]	50	100	150	200	250	300	350	400	450	500
Product weight [kg]	0.85	0.92	1.00	1.07	1.15	1.22	1.30	1.37	1.45	1.52
Additional weight with lock [kg]	0.16									

Series	LE2FS25															
Stroke [mm]	50	100	150	200	250	300	350	400	450	500	550	600	650	700	750	800
Product weight [kg]	1.77	1.91	2.05	2.19	2.33	2.47	2.61	2.75	2.89	3.03	3.17	3.31	3.45	3.59	3.73	3.87
Additional weight with lock [kg]	0.31															

Series	LE2FS32																			
Stroke [mm]	50	100	150	200	250	300	350	400	450	500	550	600	650	700	750	800	850	900	950	1000
Product weight [kg]	3.12	3.32	3.52	3.72	3.92	4.12	4.32	4.52	4.72	4.92	5.12	5.32	5.52	5.72	5.92	6.12	6.32	6.52	6.72	6.92
Additional weight with lock [kg]	0.58																			

Series	LE2FS40																			
Stroke [mm]	150	200	250	300	350	400	450	500	550	600	650	700	750	800	850	900	950	1000	1100	1200
Product weight [kg]	4.99	5.27	5.55	5.83	6.11	6.39	6.77	6.95	7.23	7.51	7.79	8.07	8.35	8.63	8.91	9.19	9.47	9.75	10.31	10.87
Additional weight with lock [kg]	0.60																			

Right/Left Side Parallel Motor

Series	LE2FS16 ^R									
Stroke [mm]	50	100	150	200	250	300	350	400	450	500
Product weight [kg]	0.85	0.92	1.00	1.07	1.15	1.22	1.30	1.37	1.45	1.52
Additional weight with lock [kg]	0.16									

Series	LE2FS25 ^R															
Stroke [mm]	50	100	150	200	250	300	350	400	450	500	550	600	650	700	750	800
Product weight [kg]	1.75	1.89	2.03	2.17	2.31	2.45	2.59	2.73	2.87	3.01	3.15	3.29	3.43	3.57	3.71	3.85
Additional weight with lock [kg]	0.31															

Series	LE2FS32 ^R																			
Stroke [mm]	50	100	150	200	250	300	350	400	450	500	550	600	650	700	750	800	850	900	950	1000
Product weight [kg]	3.09	3.29	3.49	3.69	3.89	4.09	4.29	4.49	4.69	4.89	5.09	5.29	5.49	5.69	5.89	6.09	6.29	6.49	6.69	6.89
Additional weight with lock [kg]	0.58																			

Series	LE2FS40 ^R																			
Stroke [mm]	150	200	250	300	350	400	450	500	550	600	650	700	750	800	850	900	950	1000	1100	1200
Product weight [kg]	5.15	5.43	5.71	5.99	6.27	6.55	6.93	7.11	7.39	7.67	7.95	8.23	8.51	8.79	9.07	9.35	9.63	9.91	10.47	11.03
Additional weight with lock [kg]	0.60																			

Model Selection

LE2FS□H

LE2FB□H

LE2Y□H

LE2YG□H

LE2S(H)□H

LE2R□H

Auto Switch

Dimensions: In-line Motor

LE2FS16H

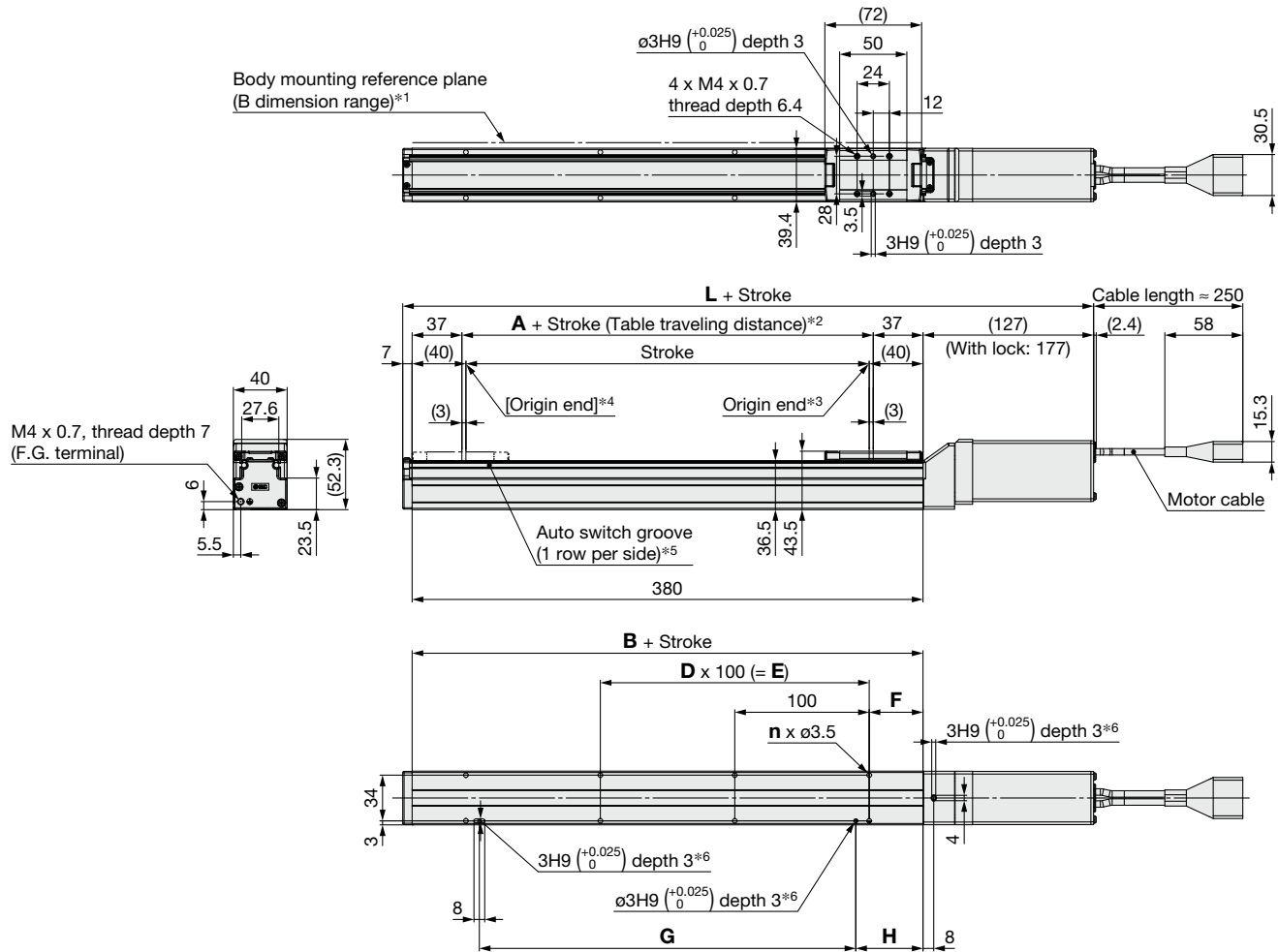

- *1 When mounting the actuator using the body mounting reference plane, set the height of the opposite surface or pin to be 3 mm or more. (Recommended height: 5 mm)
In addition, be aware that surfaces other than the body mounting reference plane (B dimension range) may slightly protrude from the body mounting reference plane. Be sure to provide a clearance of 1 mm or more to avoid interference with workpieces, facilities, etc.
- *2 The distance the table moves according to movement instructions
Make sure that workpieces mounted on the table do not interfere with other workpieces or the facilities around the table.
- *3 Indicates the factory default origin position (0 mm)
- *4 [] refers to when the rotation direction reference is changed.
- *5 The applicable auto switch (D-M9□) should be ordered separately.
- *6 When using the positioning pin holes on the bottom, use either the one on the body side or the one on the housing side.
- * The axial cable entry direction is shown.

Dimensions

Stroke	L		A	B	n	D	E	F	G	H
	Without lock	With lock								
50	214	264	6	80	4	—	—	15	80	25
100, 150					6	2	200			
200, 250					8	3	300	40	180	
300, 350					10	4	400		280	
400, 450					12	5	500		380	
500								480		

Dimensions: In-line Motor

LE2FS25H

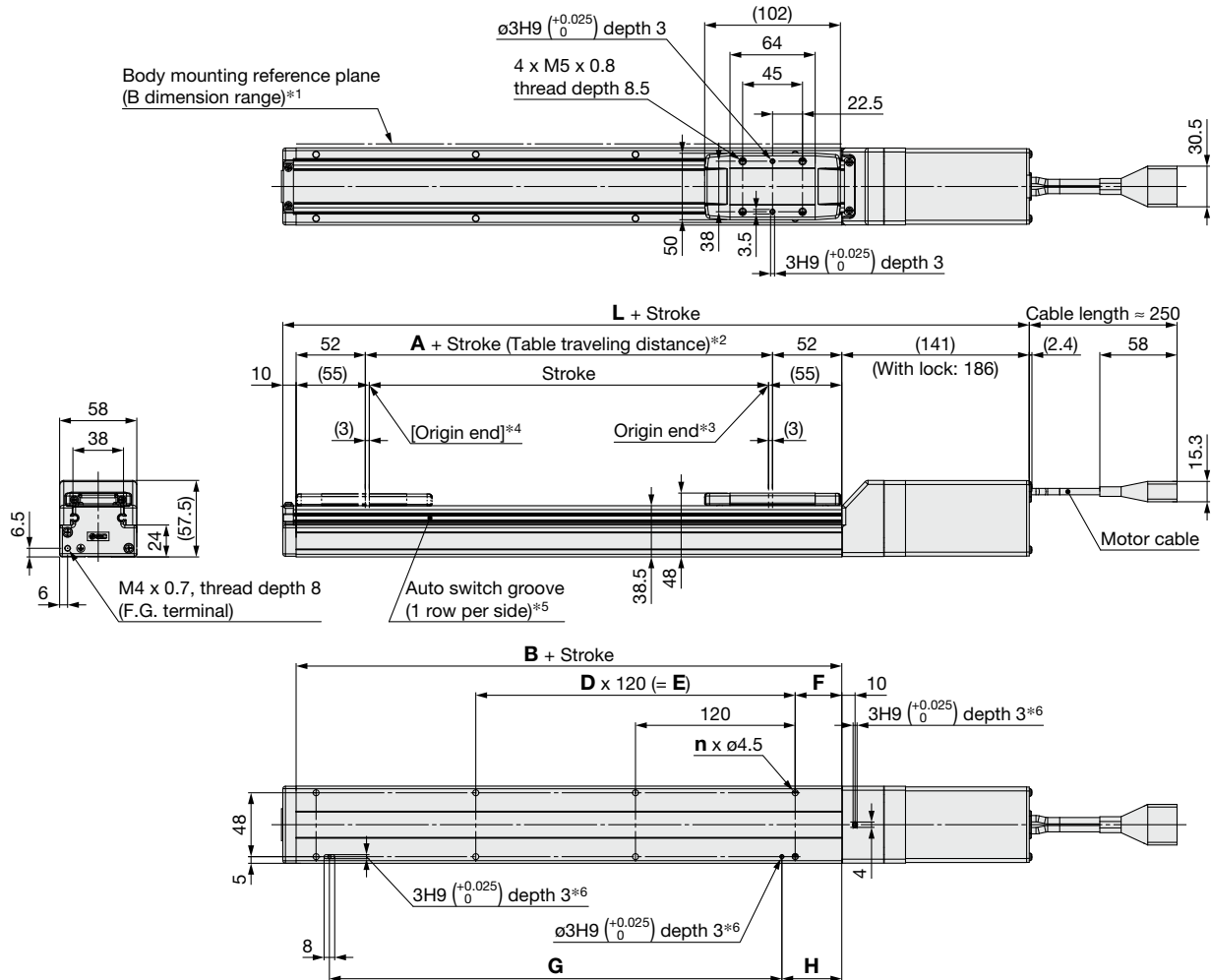

- *1 When mounting the actuator using the body mounting reference plane, set the height of the opposite surface or pin to be 3 mm or more. (Recommended height: 5 mm)
 In addition, be aware that surfaces other than the body mounting reference plane (B dimension range) may slightly protrude from the body mounting reference plane. Be sure to provide a clearance of 1 mm or more to avoid interference with workpieces, facilities, etc.
- *2 The distance the table moves according to movement instructions
 Make sure that workpieces mounted on the table do not interfere with other workpieces or the facilities around the table.
- *3 Indicates the factory default origin position (0 mm)
- *4 [] refers to when the rotation direction reference is changed.
- *5 The applicable auto switch (D-M9□) should be ordered separately.
- *6 When using the positioning pin holes on the bottom, use either the one on the body side or the one on the housing side.
- * The axial cable entry direction is shown.

Dimensions

Stroke	L		A	B	n	D	E	F	G	H
	Without lock	With lock								
50	261	306	6	110	4	—	—	20	100	30
100, 150					6	2	240			
200, 250					8	3	360			
300, 350, 400					10	4	480	35	460	
450, 500					12	5	600			
550, 600, 650					14	6	720			
700, 750					16	7	840			
800										

Model Selection

LE2FS□H

LE2FB□H

LE2Y□H

LE2YG□H

LE2S(H)□H

LE2R□H

Auto Switch

Dimensions: In-line Motor

LE2FS32H

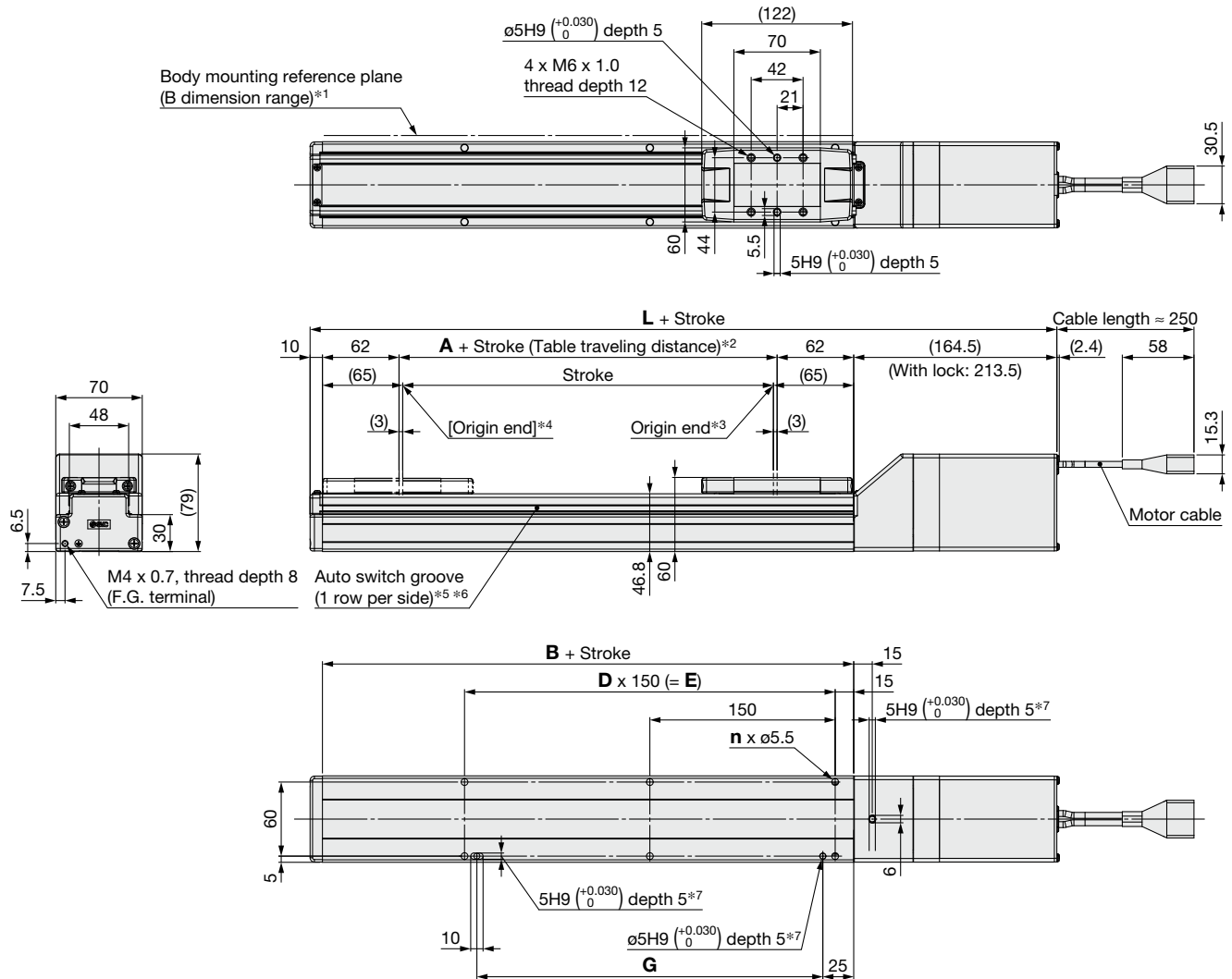

- *1 When mounting the actuator using the body mounting reference plane, set the height of the opposite surface or pin to be 3 mm or more. (Recommended height: 5 mm)
In addition, be aware that surfaces other than the body mounting reference plane (B dimension range) may slightly protrude from the body mounting reference plane. Be sure to provide a clearance of 1 mm or more to avoid interference with workpieces, facilities, etc.
- *2 The distance the table moves according to movement instructions
Make sure that workpieces mounted on the table do not interfere with other workpieces or the facilities around the table.
- *3 Indicates the factory default origin position (0 mm)
- *4 [] refers to when the rotation direction reference is changed.
- *5 The applicable auto switch (D-M9□) should be ordered separately.
- *6 A switch spacer (BM-Y3-016) is required to secure auto switches. Please order it separately.
- *7 When using the positioning pin holes on the bottom, use either the one on the body side or the one on the housing side.
- * The axial cable entry direction is shown.

Dimensions

[mm]

Stroke	L		A	B	n	D	E	G
	Without lock	With lock						
50, 100, 150	304.5	353.5	6	130	4	—	—	130
200, 250, 300					6	2	300	280
350, 400, 450					8	3	450	430
500, 550, 600					10	4	600	580
650, 700, 750					12	5	750	730
800, 850, 900					14	6	900	880
950, 1000					16	7	1050	1030

Dimensions: In-line Motor

LE2FS40H

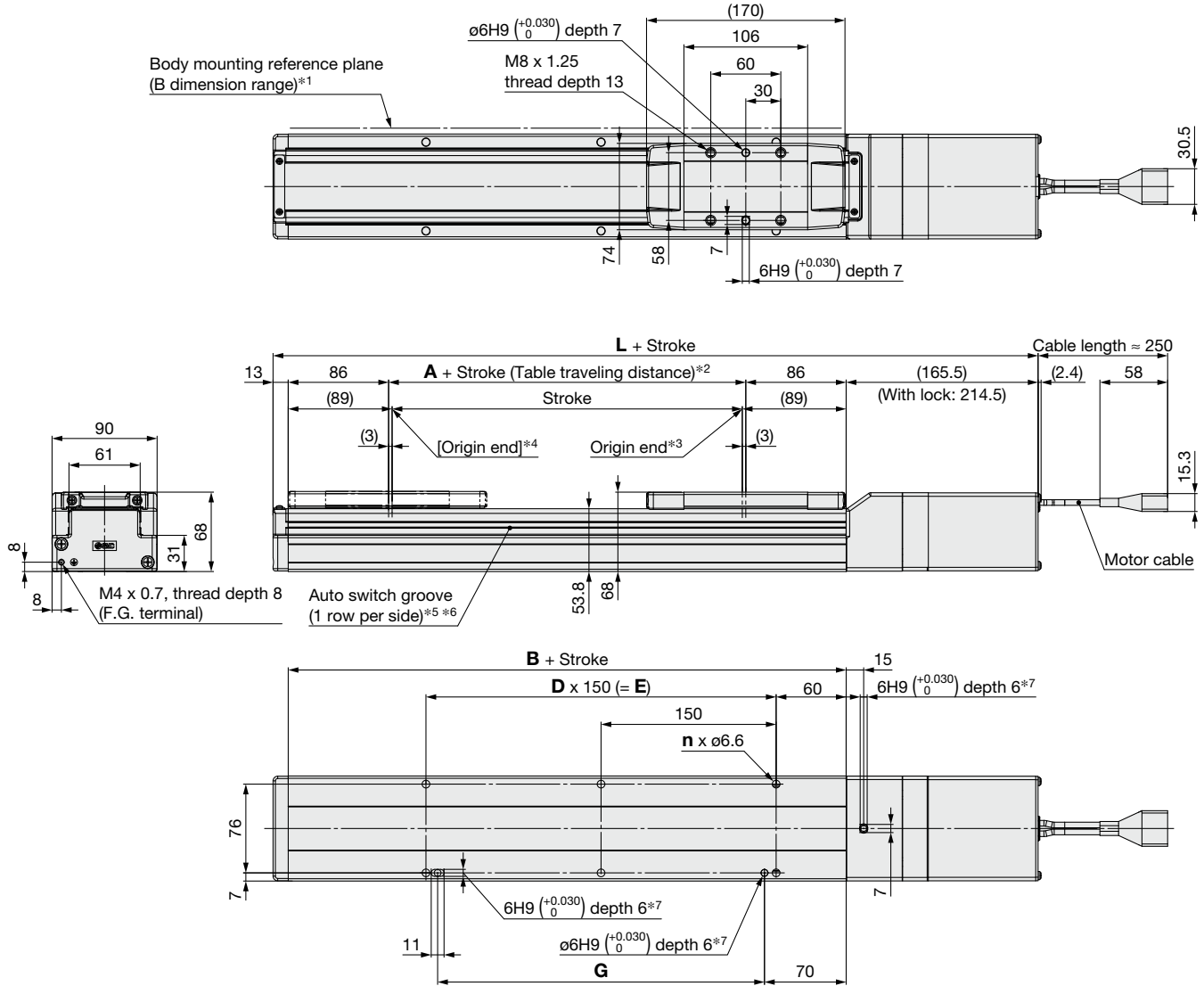

*1 When mounting the actuator using the body mounting reference plane, set the height of the opposite surface or pin to be 3 mm or more. (Recommended height: 5 mm)
 In addition, be aware that surfaces other than the body mounting reference plane (B dimension range) may slightly protrude from the body mounting reference plane. Be sure to provide a clearance of 1 mm or more to avoid interference with workpieces, facilities, etc.

*2 The distance the table moves according to movement instructions
 Make sure that workpieces mounted on the table do not interfere with other workpieces or the facilities around the table.

*3 Indicates the factory default origin position (0 mm)
 [] refers to when the rotation direction reference is changed.

*4 The applicable auto switch (D-M9□) should be ordered separately.

*5 A switch spacer (BM-Y3-016) is required to secure auto switches. Please order it separately.

*6 When using the positioning pin holes on the bottom, use either the one on the body side or the one on the housing side.

* The axial cable entry direction is shown.

Dimensions

Stroke	L		A	B	n	D	E	G
	Without lock	With lock						
150	356.5	405.5	6	178	4	—	—	130
200, 250, 300					6	2	300	280
350, 400, 450					8	3	450	430
500, 550, 600					10	4	600	580
650, 700, 750					12	5	750	730
800, 850, 900					14	6	900	880
950, 1000					16	7	1050	1030
1100, 1200					18	8	1200	1180

Model Selection

LE2FS□H

LE2FB□H

LE2Y□H

LE2YG□H

LE2S(H)□H

LE2R□H

Auto Switch

Dimensions: Right/Left Side Parallel Motor

LE2FS16(L/R)H

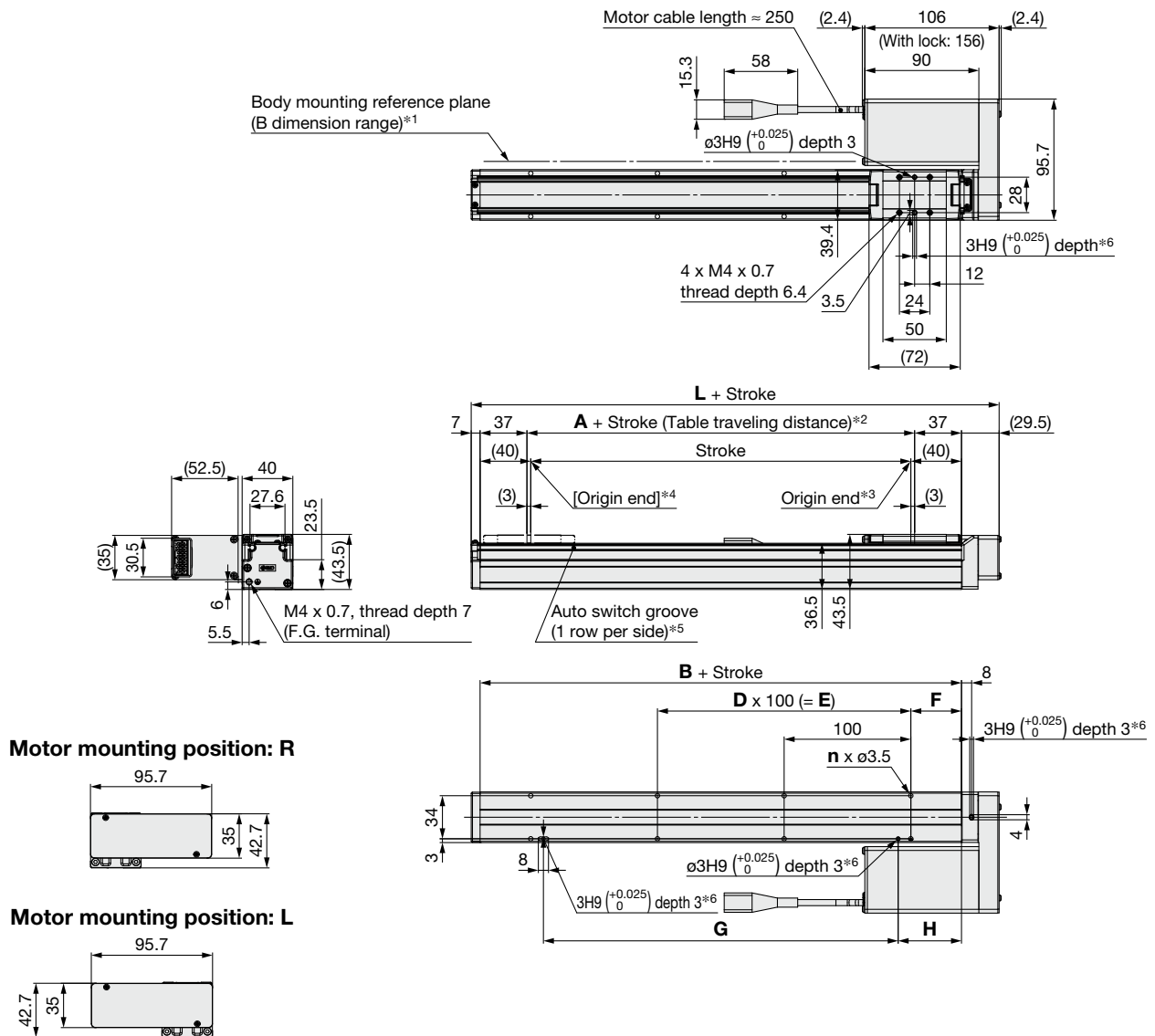

*1 When mounting the actuator using the body mounting reference plane, set the height of the opposite surface or pin to be 3 mm or more. (Recommended height: 5 mm)
 In addition, be aware that surfaces other than the body mounting reference plane (B dimension range) may slightly protrude from the body mounting reference plane. Be sure to provide a clearance of 1 mm or more to avoid interference with workpieces, facilities, etc.
 *2 The distance the table moves according to movement instructions
 Make sure that workpieces mounted on the table do not interfere with other workpieces or the facilities around the table.
 *3 Indicates the factory default origin position (0 mm)
 *4 [] refers to when the rotation direction reference is changed.
 *5 The applicable auto switch (D-M9□) should be ordered separately.
 *6 When using the positioning pin holes on the bottom, use either the one on the body side or the one on the housing side.
 * This illustration shows the motor mounting position for the right side parallel type. Refer to the catalog for detailed dimensions of the left side parallel type.
 * The axial cable entry direction is shown.

Dimensions

Stroke	L	A	B	n	D	E	F	G	H
50	116.5	6	80	4	—	—	15	80	25
100, 150				6	2	200	40	180	50
200, 250				8	3	300		280	
300, 350				10	4	400		380	
400, 450				12	5	500		480	
500									

Dimensions: Right/Left Side Parallel Motor

LE2FS25(L/R)H

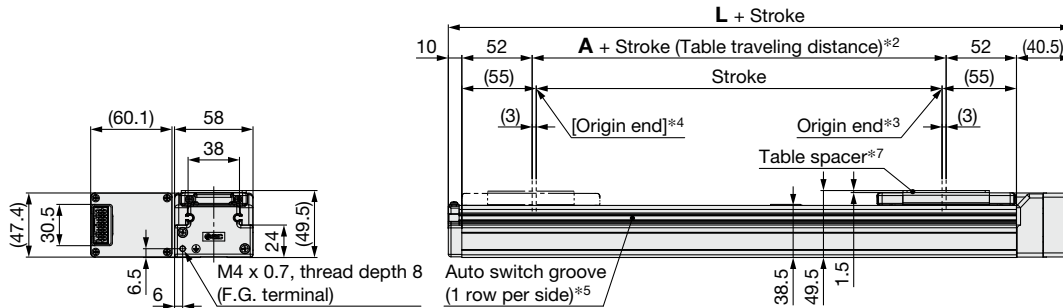
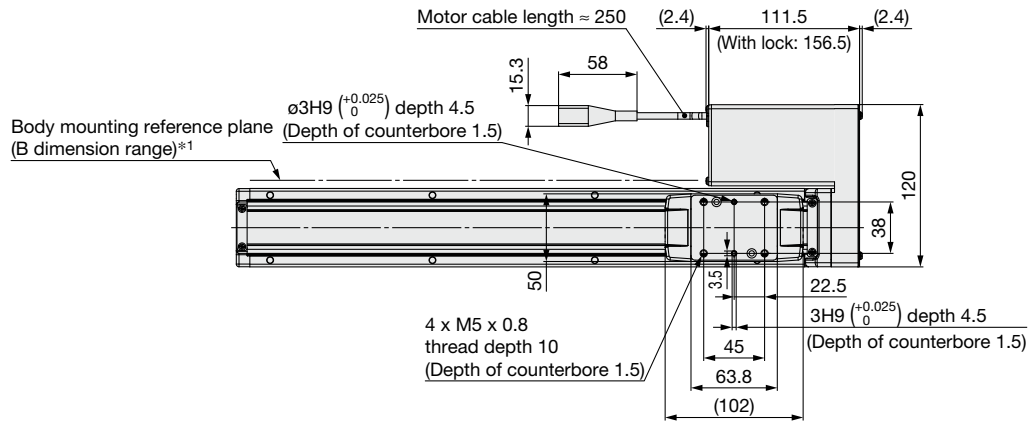

Motor mounting position: R

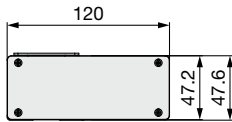

Motor mounting position: L

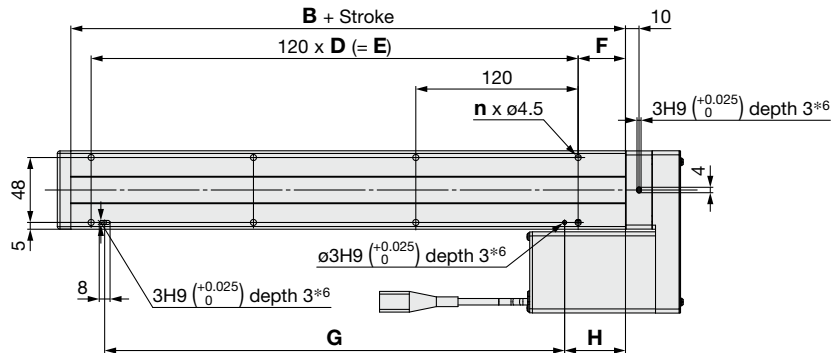
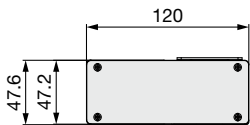

- *1 When mounting the actuator using the body mounting reference plane, set the height of the opposite surface or pin to be 3 mm or more. (Recommended height: 5 mm)
 In addition, be aware that surfaces other than the body mounting reference plane (B dimension range) may slightly protrude from the body mounting reference plane. Be sure to provide a clearance of 1 mm or more to avoid interference with workpieces, facilities, etc.
- *2 The distance the table moves according to movement instructions
 Make sure that workpieces mounted on the table do not interfere with other workpieces or the facilities around the table.
- *3 Indicates the factory default origin position (0 mm)
- *4 [] refers to when the rotation direction reference is changed.
- *5 The applicable auto switch (D-M9L) should be ordered separately.
- *6 When using the positioning pin holes on the bottom, use either the one on the body side or the one on the housing side.
- *7 The table spacer is shipped together with the product but does not come assembled.
- * This illustration shows the motor mounting position for the right side parallel type. Refer to the catalog for detailed dimensions of the left side parallel type.
- * The axial cable entry direction is shown.

Dimensions

Stroke	L	A	B	n	D	E	F	G	H
50	160.5	6	110	4	—	—	20	100	30
100, 150				6	2	240	220		
200, 250				8	3	360	340		
300, 350, 400				10	4	480	460		
450, 500				12	5	600	580		
550, 600, 650				14	6	720	700		
700, 750				16	7	840	820		
800				35	45				

Model Selection

LE2FS□H

LE2FB□H

LE2Y□H

LE2YG□H

LE2S(H)□H

LE2R□H

Auto Switch

Dimensions: Right/Left Side Parallel Motor

LE2FS32(L/R)H

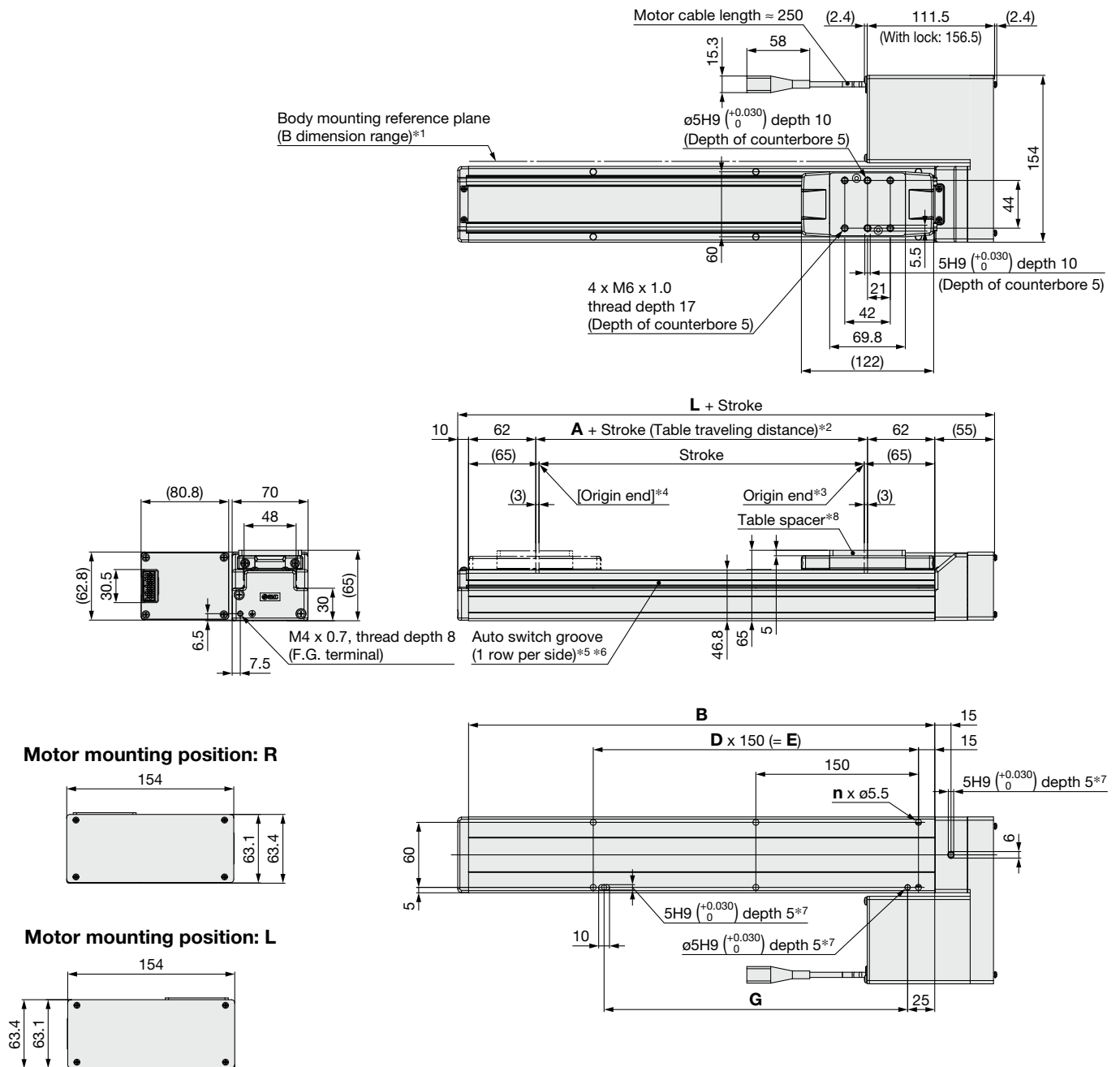

- *1 When mounting the actuator using the body mounting reference plane, set the height of the opposite surface or pin to be 3 mm or more. (Recommended height: 5 mm)
In addition, be aware that surfaces other than the body mounting reference plane (B dimension range) may slightly protrude from the body mounting reference plane. Be sure to provide a clearance of 1 mm or more to avoid interference with workpieces, facilities, etc.
- *2 The distance the table moves according to movement instructions
Make sure that workpieces mounted on the table do not interfere with other workpieces or the facilities around the table.
- *3 Indicates the factory default origin position (0 mm)
- *4 [] refers to when the rotation direction reference is changed.
- *5 The applicable auto switch (D-M9□) should be ordered separately.
- *6 A switch spacer (BMY3-016) is required to secure auto switches. Please order it separately.
- *7 When using the positioning pin holes on the bottom, use either the one on the body side or the one on the housing side.
- *8 The table spacer is shipped together with the product but does not come assembled.
- * This illustration shows the motor mounting position for the right side parallel type. Refer to the catalog for detailed dimensions of the left side parallel type.
- * The axial cable entry direction is shown.

Dimensions

Stroke	L	A	B	n	D	E	G
50, 100, 150	195	6	130	4	—	—	130
200, 250, 300				6	2	300	280
350, 400, 450				8	3	450	430
500, 550, 600				10	4	600	580
650, 700, 750				12	5	750	730
800, 850, 900				14	6	900	880
950, 1000				16	7	1050	1030

Dimensions: Right/Left Side Parallel Motor
LE2FS40(L/R)H

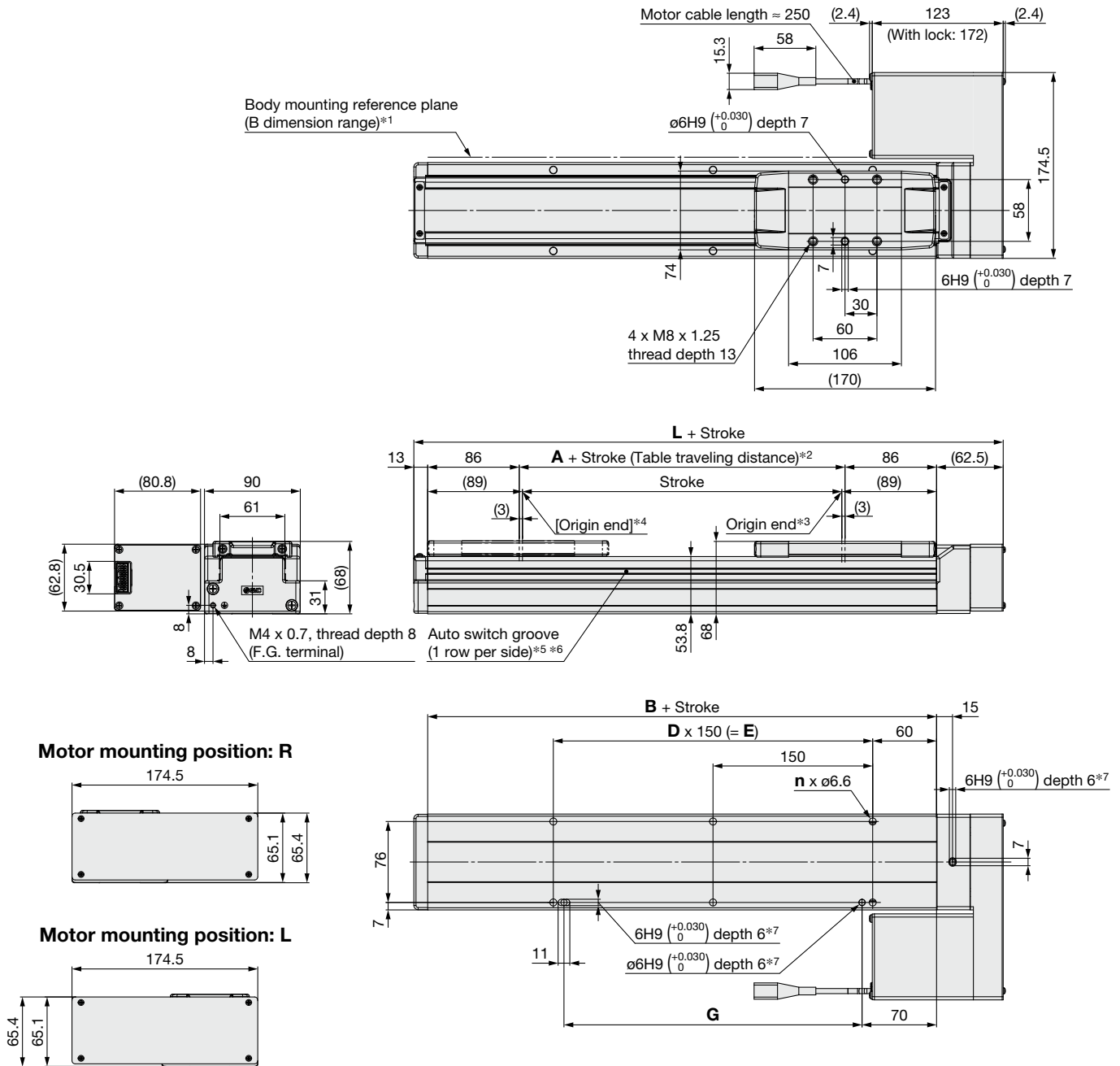

*1 When mounting the actuator using the body mounting reference plane, set the height of the opposite surface or pin to be 3 mm or more. (Recommended height: 5 mm)
 In addition, be aware that surfaces other than the body mounting reference plane (B dimension range) may slightly protrude from the body mounting reference plane. Be sure to provide a clearance of 1 mm or more to avoid interference with workpieces, facilities, etc.
 *2 The distance the table moves according to movement instructions
 Make sure that workpieces mounted on the table do not interfere with other workpieces or the facilities around the table.
 *3 Indicates the factory default origin position (0 mm)
 *4 [] refers to when the rotation direction reference is changed.
 *5 The applicable auto switch (D-M9□) should be ordered separately.
 *6 A switch spacer (BMY3-016) is required to secure auto switches. Please order it separately.
 *7 When using the positioning pin holes on the bottom, use either the one on the body side or the one on the housing side.
 * This illustration shows the motor mounting position for the right side parallel type. Refer to the catalog for detailed dimensions of the left side parallel type.
 * The axial cable entry direction is shown.

Dimensions [mm]

Stroke	L	A	B	n	D	E	G
150	253.5	6	178	4	—	—	130
200, 250, 300				6	2	300	280
350, 400, 450				8	3	450	430
500, 550, 600				10	4	600	580
650, 700, 750				12	5	750	730
800, 850, 900				14	6	900	880
950, 1000				16	7	1050	1030
1100, 1200				18	8	1200	1180

Model Selection

LE2FS□H

LE2FB□H

LE2Y□H

LE2YG□H

LE2S(H)□H

LE2R□H

Auto Switch

LE2FS□H Series Auto Switch Mounting

Detailed specifications: From p. 131

Auto Switch Mounting Position

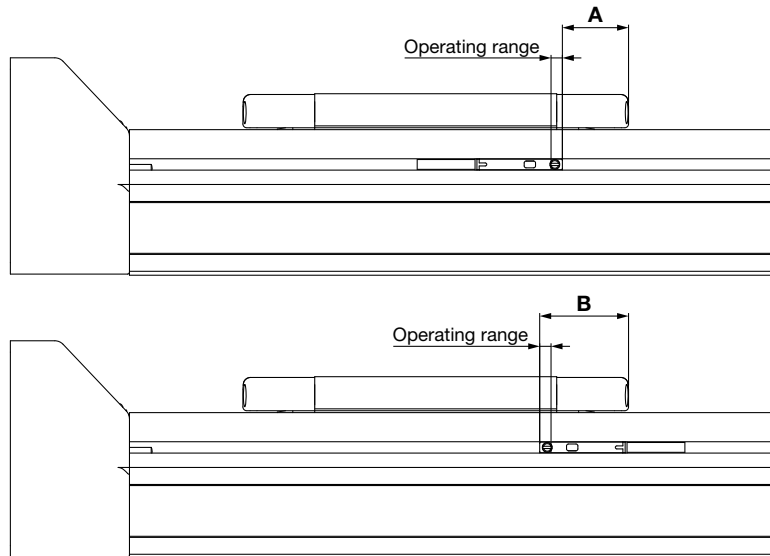

Table 1 Auto Switch Mounting Dimensions [mm]

Model	Size	A	B	Operating range
LE2FS	16	12.5	24.5	3.0
	25	17.5	29.5	3.0
	32	26.3	39.1	3.4
	40	32.2	45.4	3.6

- * The applicable auto switch is D-M9 (N/P/B) (W) (M/L/Z).
- * The operating range is a guideline including hysteresis, not meant to be guaranteed. There may be large variations depending on the ambient environment.
- * Adjust the auto switch after confirming the operating conditions in the actual setting.

Auto Switch Mounting

LE2FS16/25

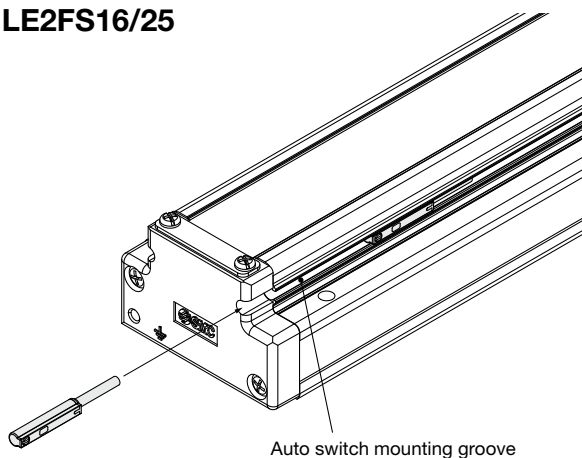

Auto switch mounting groove

Auto Switch Mounting Screw

Tightening torque [N·m]
0.1 to 0.15

LE2FS32/40

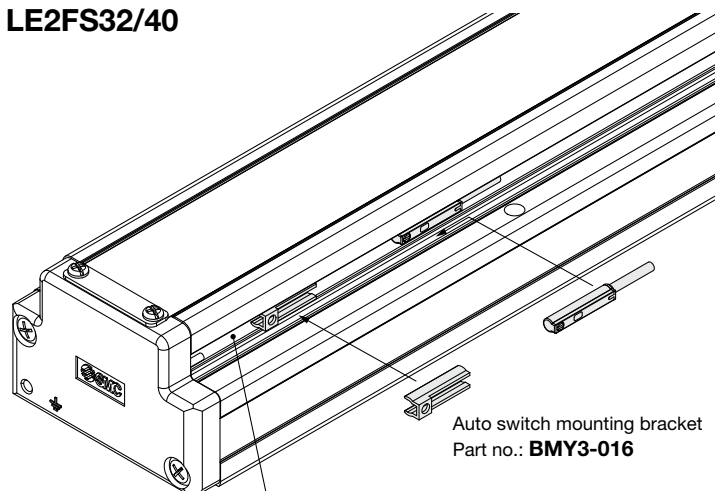

Auto switch mounting bracket
Part no.: **BMY3-016**

Auto switch mounting groove

- * The applicable auto switch is D-M9 (N/P/B) (W) (M/L/Z).
- * When tightening the auto switch mounting screw (included with the auto switch), use a watchmaker's screwdriver with a handle diameter of 5 to 6 mm.
- * Prepare an auto switch mounting bracket (BMY3-016) when mounting the auto switch on to the LE2FS32/40.

Slider Type/Belt Drive

LE2FB□H Series

p. 31

Battery-less Absolute (Step Motor 24 VDC)



Model Selection

LE2FS□H

LE2FB□H

LE2Y□H

LE2YG□H

LE2S(H)□H

LE2R□H

Auto Switch

Compatible with Manifold Controller

Slider Type/Belt Drive

LE2FB□H Series Battery-less Absolute (Step Motor 24 VDC)

Model Selection



Speed-Work Load Graph (Guide)

* The following graph shows the values when the moving force is 100%.

LE2FB/Belt Drive

Horizontal

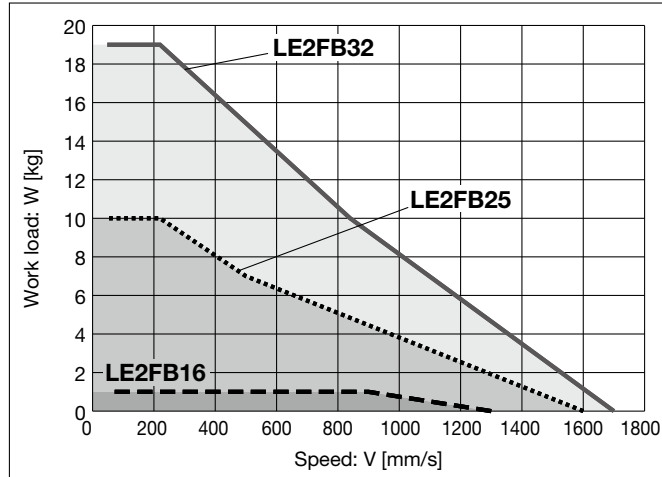

Dynamic Allowable Moment

* These graphs show the amount of allowable overhang (guide unit) when the center of gravity of the workpiece overhangs in one direction.

Acceleration ——— 1000 mm/s² - - - 3000 mm/s²

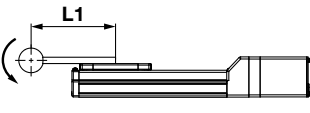
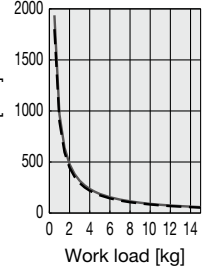
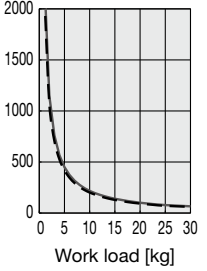
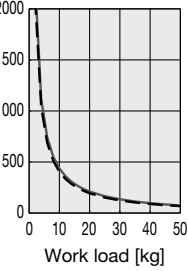
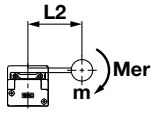
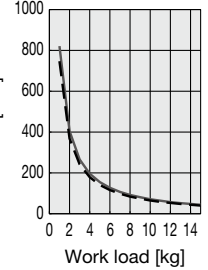
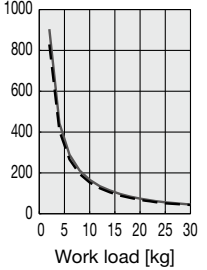
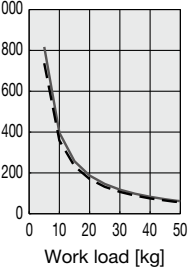
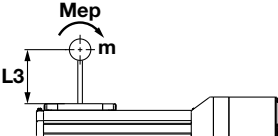
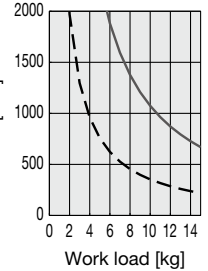
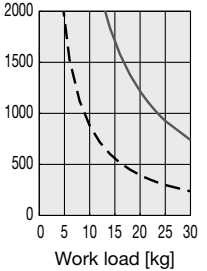
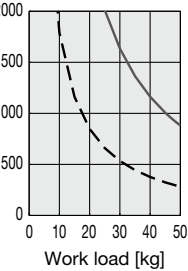
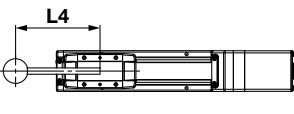
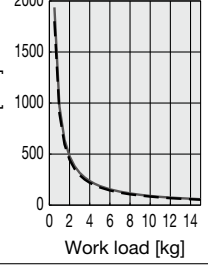
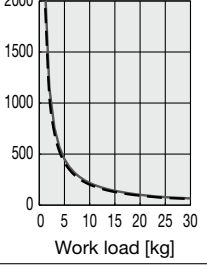
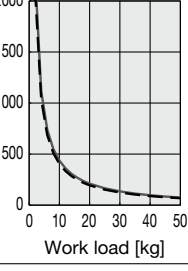
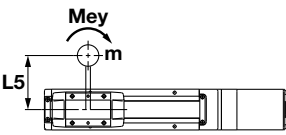
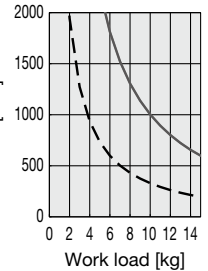
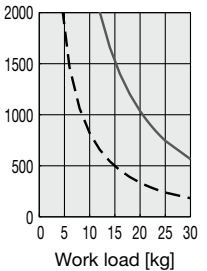
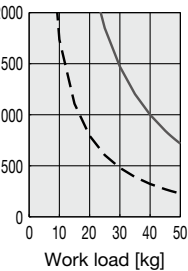
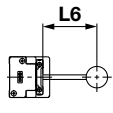
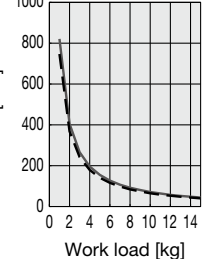
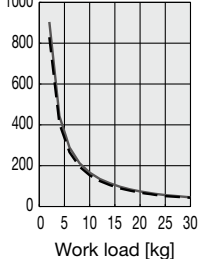
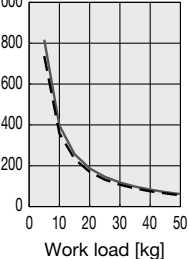
Orientation	Load overhanging direction m : Work load [kg] Me: Allowable moment [N·m] L : Overhang to the work load center of gravity [mm]	Model		
		LE2FB16H	LE2FB25H	LE2FB32H
Horizontal/Bottom	 X			
	 Y			
	 Z			
Wall	 X			
	 Y			
	 Z			

Model Selection

LE2FS□H

LE2FB□H

LE2Y□H

LE2YG□H

LE2S(H)□H

LE2R□H

Auto Switch

Table Accuracy (Reference Value)

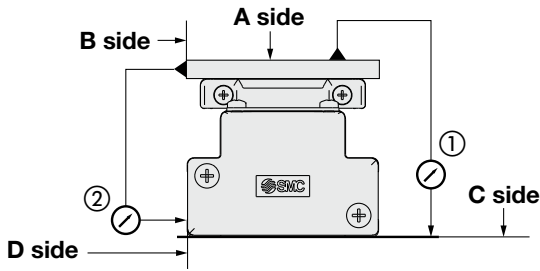

Model	Traveling parallelism [mm] (Every 300 mm)	
	① C side traveling parallelism to A side	② D side traveling parallelism to B side
LE2FB16H	0.05	0.03
LE2FB25H	0.05	0.03
LE2FB32H	0.05	0.03

* Traveling parallelism does not include the mounting surface accuracy. (Excludes when the stroke exceeds 2000 mm)

Table Displacement (Reference Value)

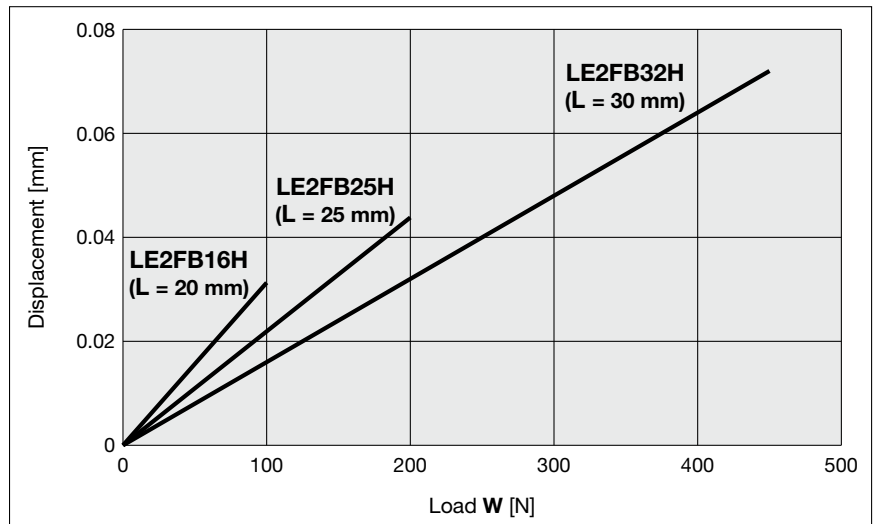
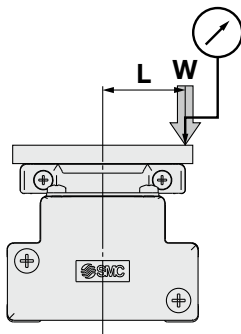

* This displacement is measured when a 15 mm aluminum plate is mounted and fixed on the table.
 * Check the clearance and play of the guide separately.

Overhang Displacement Due to Table Clearance (Initial Reference Value)

Basic type

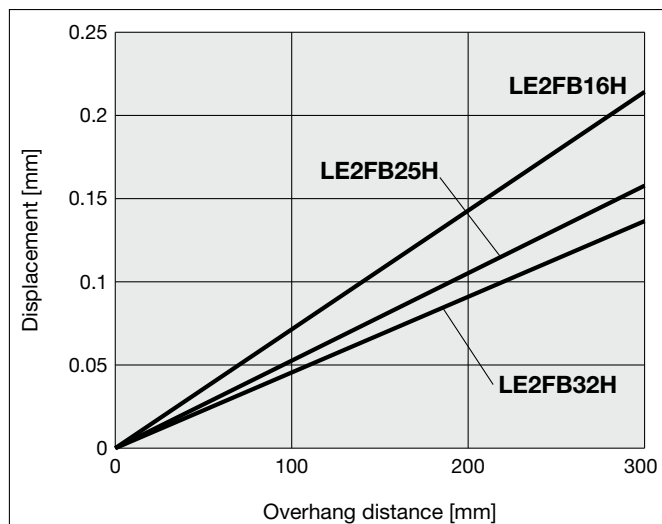

Compatible with Manifold Controller

Slider Type/Belt Drive

LE2FB□H Series LE2FB16, 25, 32



How to Order

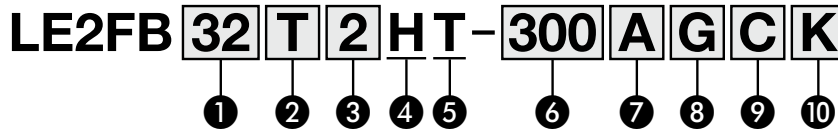

1 Size

16
25
32

2 Motor mounting position

T	Top mounting
U	Bottom mounting

3 Motor cable entry direction

2	Right
3	Left
4	Top
5	Bottom
6	Front
7	Back

4 Motor type

Symbol	Type	Compatible controller
H	Battery-less absolute (Step motor 24 VDC)	JXD1

5 Equivalent lead [mm]

Symbol	LE2FB16	LE2FB25	LE2FB32
T		48	

6 Stroke*1

300	300
to	to
2600	2600

* For details, refer to the applicable stroke table below.

7 Motor option

A	Without option
B	With lock

8 Grease application (Seal band part)

G	With
N	Without (Roller specification)

9 Auto switch compatibility*2 *3 *4 *5

Nil	None
C	With (Includes 1 mounting bracket)

10 Positioning pin hole

Nil *6	Housing B bottom	
K	Body bottom 2 locations	

- *1 Please contact SMC for non-standard strokes as they are produced as special orders.
- *2 Excludes the LE2FB16
- *3 If 2 or more are required, please order them separately.
- *4 Order auto switches separately.
- *5 When "Nil" is selected, the product will not come with a built-in magnet for an auto switch, and so a mounting bracket cannot be secured.
- *6 Motor mounting position "T" only

Applicable Stroke Table

●: Standard/○: Produced upon receipt of order

Size	Stroke													
	300	500	600	700	800	900	1000	1200	1500	1800	2000	2200	2400	2600
16	●	●	●	●	●	●	●	○	—	—	—	—	—	—
25	●	●	●	●	●	●	●	●	●	●	●	○	—	—
32	●	●	●	●	●	●	●	●	●	●	●	○	○	○

The auto switches should be ordered separately. For details, refer to pages 40 and 131 to 133.

Motor Mounting Position

U: Bottom mounting

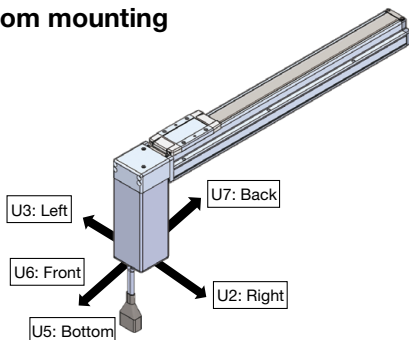

T: Top mounting

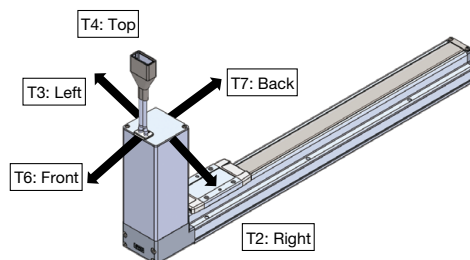

Model Selection

LE2FS□H

LE2FB□H

LE2Y□H

LE2YG□H

LE2S(H)□H

LE2R□H

Auto Switch

Specifications

Model		LE2FB16□H	LE2FB25□H	LE2FB32□H	
Actuator specifications	Stroke [mm]*1	300, 500, 600, 700 800, 900, 1000, 1200	300, 500, 600, 700, 800, 900, 1000, 1200, 1500, 1800, 2000, 2200	300, 500, 600, 700, 800, 900, 1000, 1200, 1500, 1800, 2000, 2200, 2400, 2600	
	Work load [kg]	Horizontal	1	10	19
	Speed [mm/s]		48 to 1300	48 to 1600	48 to 1700
	Max. acceleration/deceleration [mm/s ²]			3000	
	Positioning repeatability [mm]			±0.08	
	Lost motion [mm]*2			0.1 or less	
	Lead [mm]		48	48	48
	Impact/Vibration resistance [m/s ²]*3			50/20	
	Actuation type			Belt	
	Guide type			Linear guide	
	Static allowable moment*4 [N·m]	Mep (Pitching)	10	27	46
		Mey (Yawing)	10	27	46
		Mer (Rolling)	20	52	101
	Operating temperature range [°C]			5 to 40	
	Operating humidity range [%RH]			90 or less (No condensation)	
	Enclosure			IP30	
Motor size		□28	□42	□56.4	
Motor type		Battery-less absolute (Step motor 24 VDC)			
Encoder		Battery-less absolute			
Power supply voltage [V]		24 VDC ±10%			
Power [W]*5 *7		Max. power 22	Max. power 40	Max. power 62	
Type*6		Non-magnetizing lock			
Holding force [N]		4	19	36	
Power [W]*7		4	8	8	
Rated voltage [V]		24 VDC ±10%			

*1 Please contact SMC for non-standard strokes as they are produced as special orders.

*2 A reference value for correcting errors in reciprocal operation

*3 Impact resistance: No malfunction occurred when the actuator was tested with a drop tester in both a sending direction and a perpendicular direction to the belt. (The test was performed with the actuator in the initial state.)

Vibration resistance: No malfunction occurred in a test ranging between 45 to 2000 Hz. The test was performed in both a sending direction and a perpendicular direction to the belt. (The test was performed with the actuator in the initial state.)

*4 The static allowable moment is the amount of static moment which can be applied to the actuator when it is stopped.

If the product is exposed to impact or repeated load, be sure to take adequate safety measures when using the product.

*5 Indicates the max. power during operation (excluding the controller). This value can be used for the selection of the power supply.

*6 With lock only

*7 For an actuator with lock, add the power for the lock.

Weight

Motor Top Mounting

Series	LE2FB16T							
Stroke [mm]	300	500	600	700	800	900	1000	1200
Product weight [kg]	1.22	1.48	1.61	1.74	1.87	2	2.13	2.39
Additional weight with lock [kg]	0.19							

Series	LE2FB25T											
Stroke [mm]	300	500	600	700	800	900	1000	1200	1500	1800	2000	2200
Product weight [kg]	2.31	2.77	3	3.23	3.46	3.69	3.92	4.38	5.07	5.76	6.22	6.68
Additional weight with lock [kg]	0.34											

Series	LE2FB32T													
Stroke [mm]	300	500	600	700	800	900	1000	1200	1500	1800	2000	2200	2400	2600
Product weight [kg]	3.59	4.27	4.61	4.95	5.29	5.63	5.97	6.65	7.67	8.69	9.37	10.05	10.73	11.41
Additional weight with lock [kg]	0.63													

Motor Bottom Mounting

Series	LE2FB16U							
Stroke [mm]	300	500	600	700	800	900	1000	1200
Product weight [kg]	1.24	1.5	1.63	1.76	1.89	2.02	2.15	2.41
Additional weight with lock [kg]	0.19							

Series	LE2FB25U											
Stroke [mm]	300	500	600	700	800	900	1000	1200	1500	1800	2000	2200
Product weight [kg]	2.39	2.85	3.08	3.31	3.54	3.77	4	4.46	5.15	5.84	6.3	6.76
Additional weight with lock [kg]	0.34											

Series	LE2FB32U													
Stroke [mm]	300	500	600	700	800	900	1000	1200	1500	1800	2000	2200	2400	2600
Product weight [kg]	3.81	4.49	4.83	5.17	5.51	5.85	6.19	6.87	7.89	8.91	9.59	10.27	10.95	11.63
Additional weight with lock [kg]	0.63													

Model Selection

LE2FS□H

LE2FB□H

LE2Y□H

LE2YG□H

LE2S(H)□H

LE2R□H

Auto Switch

Dimensions: Motor Top/Bottom Mounting

LE2FB16 (T/U)

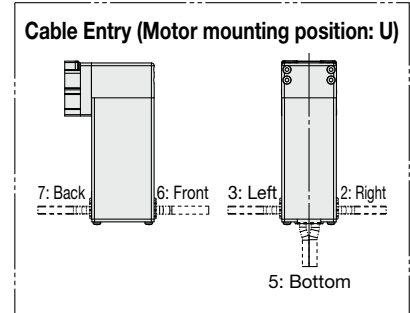
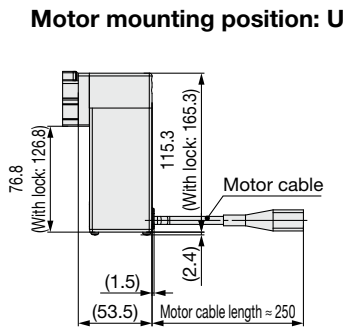
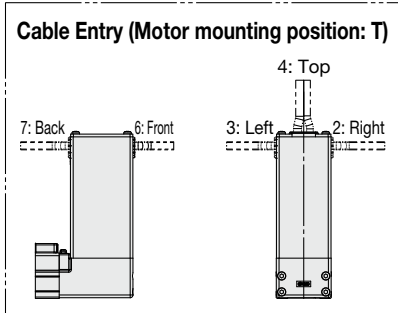
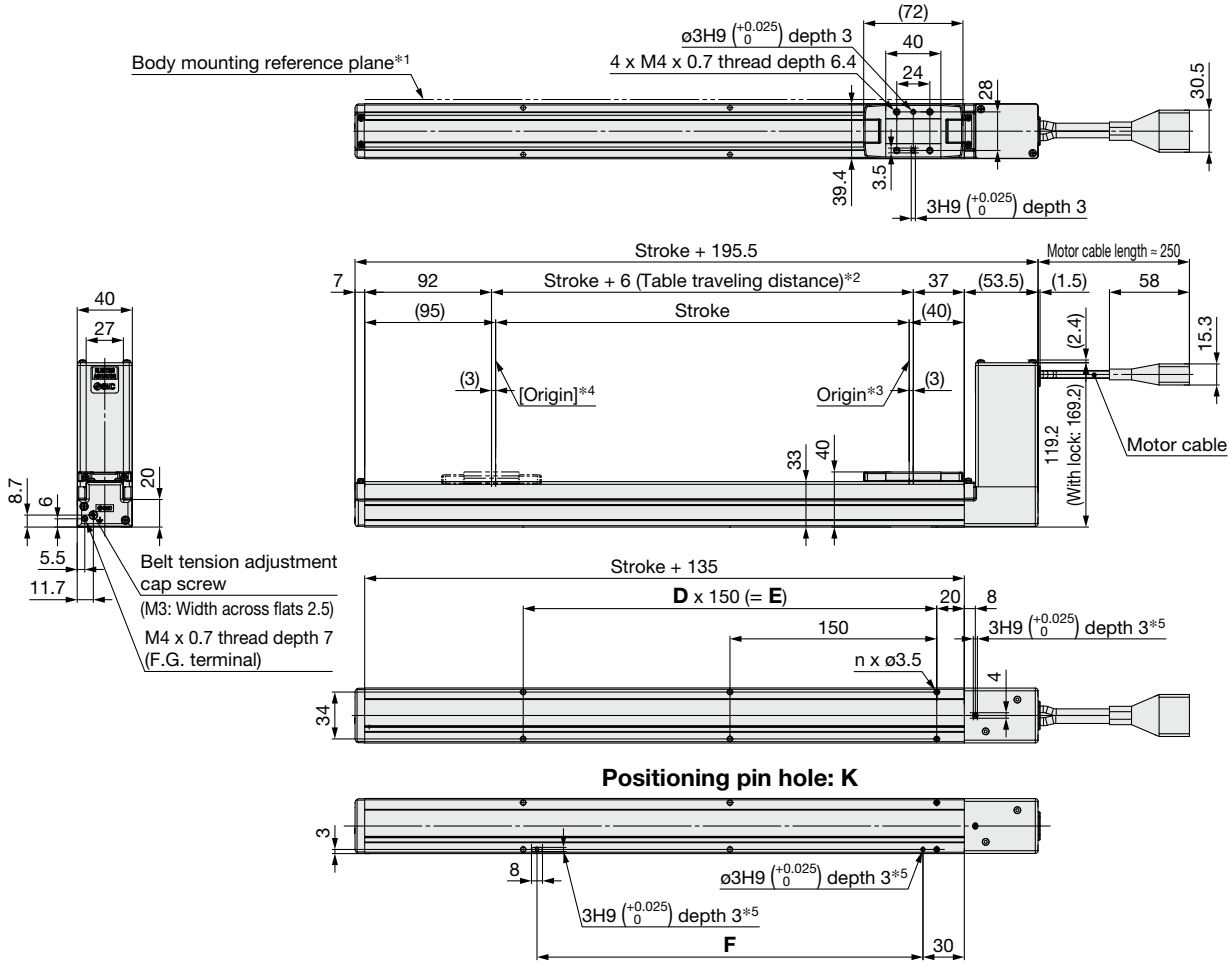

- *1 When mounting the actuator using the body mounting reference plane, set the height of the opposite surface or pin to be 2 mm or more. (Recommended height: 5 mm)
- *2 The distance the table moves according to movement instructions
Make sure that workpieces mounted on the table do not interfere with other workpieces or the facilities around the table.
- *3 Indicates the factory default origin position (0 mm)
- *4 [] refers to when the rotation direction reference is changed.
- *5 The housing B bottom pin hole is only for motor mounting position "T."
When using the body bottom pin holes, do not simultaneously use the housing B bottom pin hole.
- * These figures show motor mounting position "T" (top mounting) and motor cable entry direction "6" (front).

Dimensions

Stroke	n	D	E	F
				(Pin hole: K only)
300	6	2	300	280
500	10	4	600	580
600	10	4	600	580
700	12	5	750	730
800	14	6	900	880
900	14	6	900	880
1000	16	7	1050	1030
1200	18	8	1200	1180

Dimensions: Motor Top/Bottom Mounting

LE2FB25 (T/U)

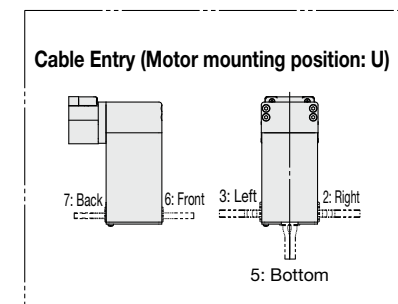
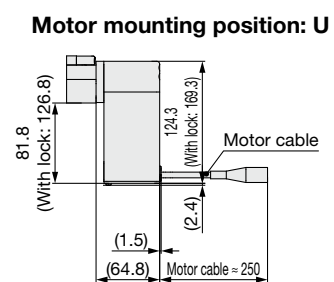
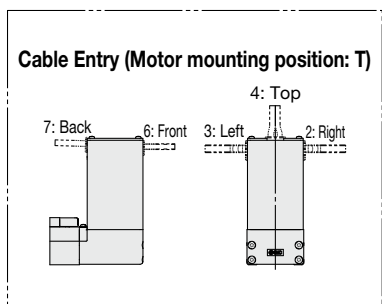
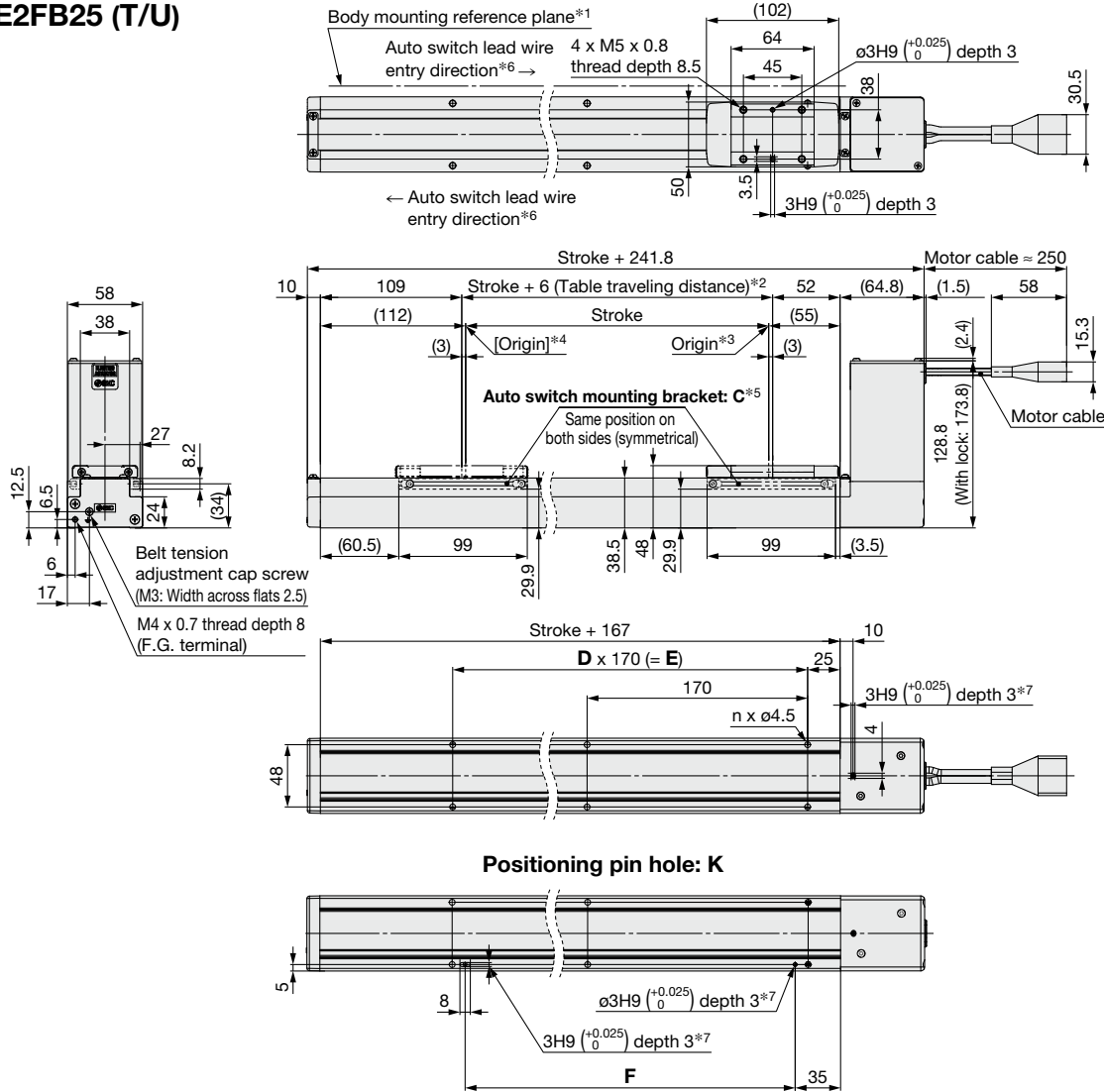

- *1 When mounting the actuator using the body mounting reference plane, set the height of the opposite surface or pin to be 3 mm or more. (Recommended height: 5 mm)
- *2 The distance the table moves according to movement instructions. Make sure that workpieces mounted on the table do not interfere with other workpieces or the facilities around the table.
- *3 Indicates the factory default origin position (0 mm)
- *4 [] refers to when the rotation direction reference is changed.
- *5 The auto switch mounting bracket mounting position (stroke end only) is shown. The auto switch magnet is located in the table center. In addition, the auto switch mounting bracket (1 pc.) is included with the product. Additional auto switch mounting brackets must be ordered separately. (Order no.: LEF-D-2-1)
- *6 The applicable auto switch (D-M9□) should be ordered separately. In addition, the auto switch lead wire entry direction is predetermined. If it is mounted in the opposite direction, the auto switch may malfunction.
- *7 The housing B bottom pin hole is only for motor mounting position "T." When using the body bottom pin holes, do not simultaneously use the housing B bottom pin hole.
- * These figures show motor mounting position "T" (top mounting) and motor cable entry direction "6" (front).

Dimensions [mm]

Stroke	n	D	E	F (Pin hole: K only)
300	6	2	340	320
500	8	3	510	490
600	10	4	680	660
700	10	4	680	660
800	12	5	850	830
900	14	6	1020	1000
1000	14	6	1020	1000
1200	16	7	1190	1170
1500	20	9	1530	1510
1800	24	11	1870	1850
2000	26	12	2040	2020
2200	28	13	2210	2190

Model Selection
 LE2FS□H
 LE2FB□H
 LE2Y□H
 LE2YG□H
 LE2S(H)□H
 LE2R□H
 Auto Switch

Dimensions: Motor Top/Bottom Mounting

LE2FB32 (T/U)

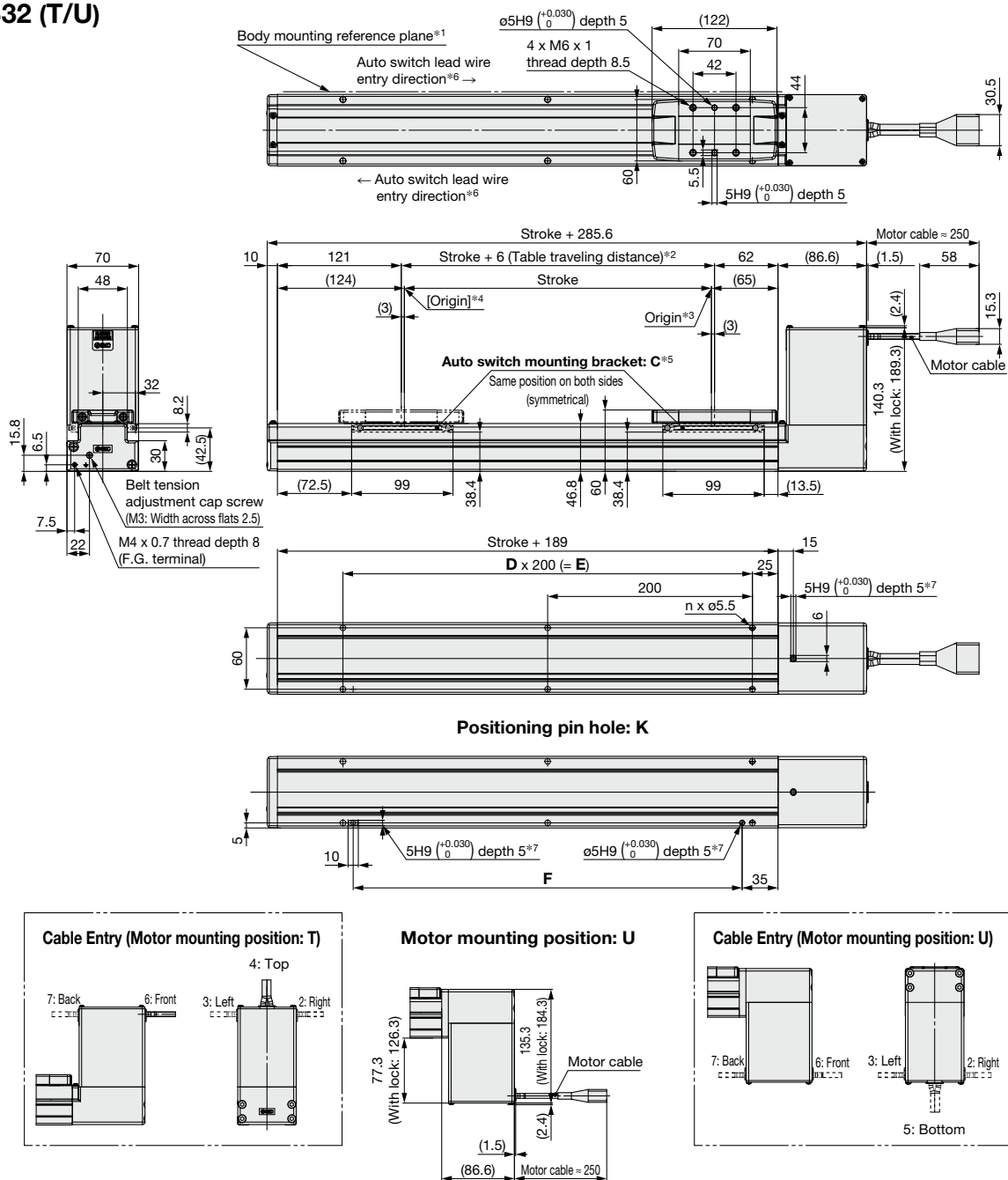

*1 When mounting the actuator using the body mounting reference plane, set the height of the opposite surface or pin to be 3 mm or more. (Recommended height: 5 mm)

*2 The distance the table moves according to movement instructions
Make sure that workpieces mounted on the table do not interfere with other workpieces or the facilities around the table.

*3 Indicates the factory default origin position (0 mm)

*4 [] refers to when the rotation direction reference is changed.

*5 The auto switch mounting bracket mounting position (stroke end only) is shown.
The auto switch magnet is located in the table center.
In addition, the auto switch mounting bracket (1 pc.) is included with the product.
Additional auto switch mounting brackets must be ordered separately. (Order no.: LEF-D-2-1)

*6 The applicable auto switch (D-M9□) should be ordered separately.
In addition, the auto switch lead wire entry direction is predetermined.
If it is mounted in the opposite direction, the auto switch may malfunction.

*7 The housing B bottom pin hole is only for motor mounting position "T."
When using the body bottom pin holes, do not simultaneously use the housing B bottom pin hole.

* These figures show motor mounting position "T" (top mounting) and motor cable entry direction "6" (front).

Dimensions

Stroke	n	D	E	F (Pin hole: K only)
300	6	2	400	380
500	8	3	600	580
600	8	3	600	580
700	10	4	800	780
800	10	4	800	780
900	12	5	1000	980
1000	12	5	1000	980
1200	14	6	1200	1180
1500	18	8	1600	1580
1800	20	9	1800	1780
2000	22	10	2000	1980
2200	24	11	2200	2180
2400	26	12	2400	2380
2600	28	13	2600	2580

LE2FB□H Series Auto Switch Mounting

Auto Switch Mounting Position

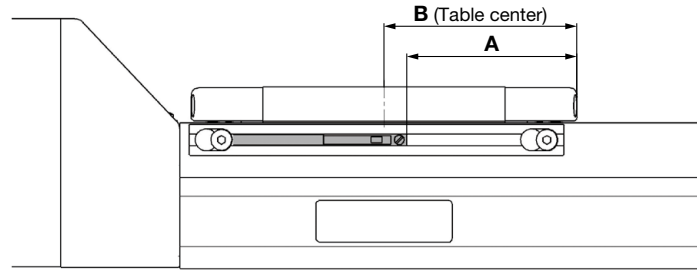

Model	Size	A	B	Operating range
LE2FB	25	45	51	4.9
	32	55	61	3.9

- * The applicable auto switch is D-M9 (N/P/B) (W) (M/L/Z).
- * The operating range is a guideline including hysteresis, not meant to be guaranteed. There may be large variations depending on the ambient environment.
- * Adjust the auto switch after confirming the operating conditions in the actual setting.

Auto Switch Mounting

Rotate the bolts for auto switch mounting bracket three to four times to loosen them (Removing them is not required), and slide and remove the auto switch mounting bracket. Then, insert a switch into the groove on the mounting bracket. As the mounting bolts for installing the product body interfere with the auto switch mounting bracket, mount the auto switch mounting bracket after installing the product body. After installing product body, tighten the bolts for the auto switch mounting bracket.

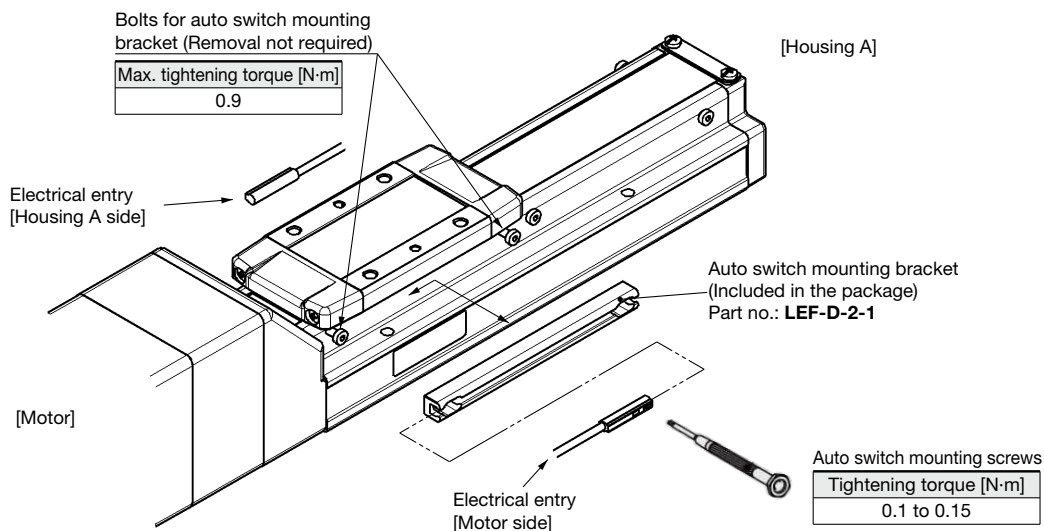

- * The applicable auto switch is D-M9 (N/P/B) (W) (M/L/Z).
- * The direction of the lead wire entry is specified. If it is mounted in the opposite direction, the auto switch may malfunction.
- * Tighten the auto switch mounting screws (provided together with the auto switch), using a precision screwdriver with a handle diameter of approximately 5 to 6 mm.
- * If more than two auto switch mounting brackets are required, please order them separately. All eight bolts for attaching the auto switch mounting bracket at the stroke end are tightened into the body when the product is shipped. For 50-mm stroke type, only four bolts are tightened on the motor side.

Model Selection

LE2FS□H

LE2FB□H

LE2Y□H

LE2YG□H

LE2S(H)□H

LE2R□H

Auto Switch

Rod Type

LE2Y□H Series

p. 43

Battery-less Absolute (Step Motor 24 VDC)

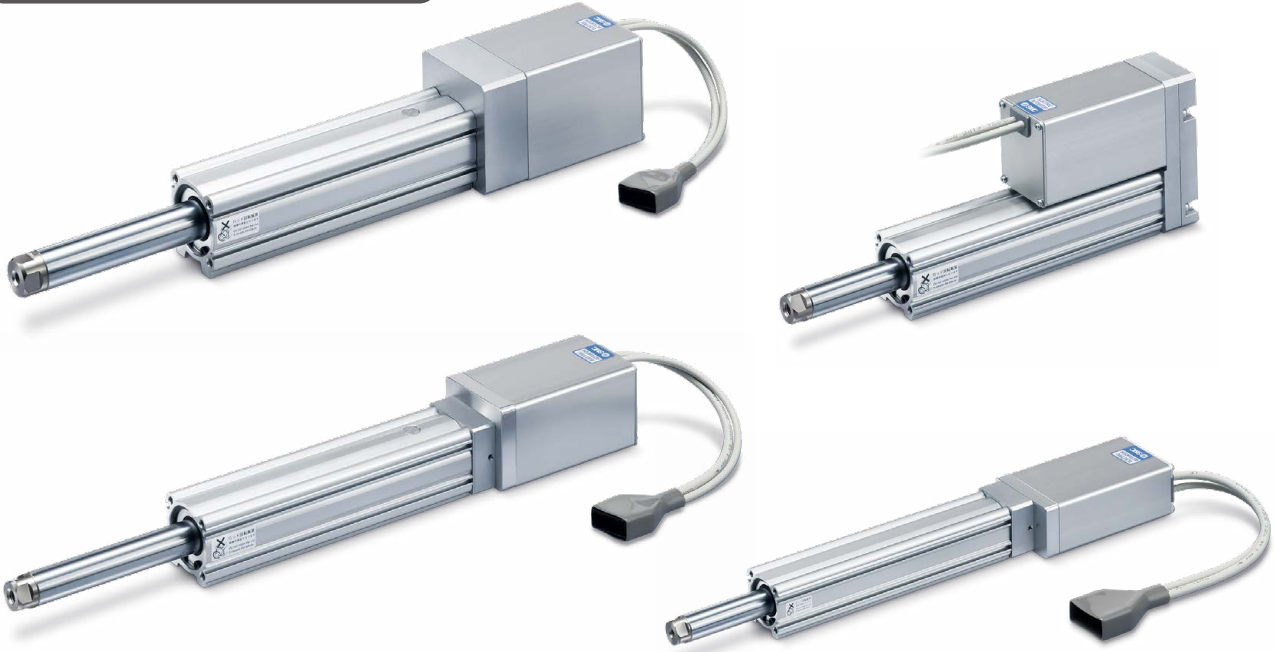

Model Selection

LE2FS□H

LE2FB□H

LE2Y□H

LE2YG□H

LE2S(H)□H

LE2R□H

Auto Switch

Model Selection

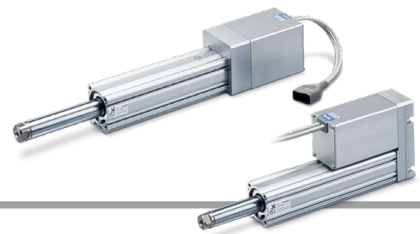

Selection Procedure

Positioning Control Selection Procedure



Selection Example

Operating conditions

- Workpiece mass: 2 [kg]
- Speed: 100 [mm/s]
- Acceleration/Deceleration: 5000 [mm/s²]
- Stroke: 200 [mm]
- Workpiece mounting condition: Vertical upward downward transfer

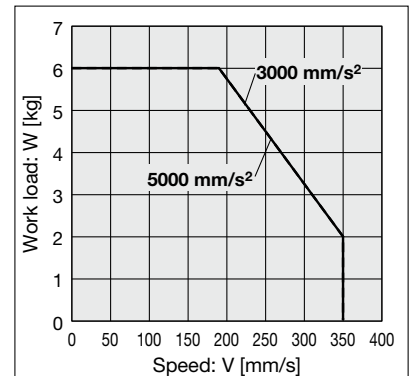

<Speed-Vertical work load graph>
(LE2Y16□HB/Step motor)

Step 1 Check the work load–speed. <Speed-Vertical work load graph>

Select a model based on the workpiece mass and speed while referencing the speed–vertical work load graph.

Selection example) The LE2Y16T□HB-200 can be temporarily selected as a possible candidate based on the graph shown on the right side.

* It is necessary to mount a guide outside the actuator when used for horizontal transfer. When selecting the target model, refer to the horizontal work load in the specifications on page 51 and the precautions.

Step 2 Check the cycle time.

Calculate the cycle time using the following calculation method.

Cycle time:

T can be found from the following equation.

$$T = T1 + T2 + T3 + T4 \text{ [s]}$$

- T1: Acceleration time and T3: Deceleration time can be found by the following equation.

$$T1 = V/a1 \text{ [s]} \quad T3 = V/a2 \text{ [s]}$$

- T2: Constant speed time can be found from the following equation.

$$T2 = \frac{L - 0.5 \cdot V \cdot (T1 + T3)}{V} \text{ [s]}$$

- T4: Settling time varies depending on the conditions such as actuator types, load, and in position of the step data. Reference value for settling time: 0.15 s or less. The following value is used for this calculation.

$$T4 = 0.15 \text{ [s]}$$

Calculation example)

T1 to T4 can be calculated as follows.

$$T1 = V/a1 = 100/5000 = 0.02 \text{ [s]}, \quad T3 = V/a2 = 100/5000 = 0.02 \text{ [s]}$$

$$T2 = \frac{L - 0.5 \cdot V \cdot (T1 + T3)}{V} = \frac{200 - 0.5 \cdot 100 \cdot (0.02 + 0.02)}{100} = 1.98 \text{ [s]}$$

$$T4 = 0.15 \text{ [s]}$$

The cycle time can be found as follows.

$$T = T1 + T2 + T3 + T4 = 0.02 + 1.98 + 0.02 + 0.15 = 2.17 \text{ [s]}$$

Based on the above calculation result, the LE2Y16T□HB-200 should be selected.

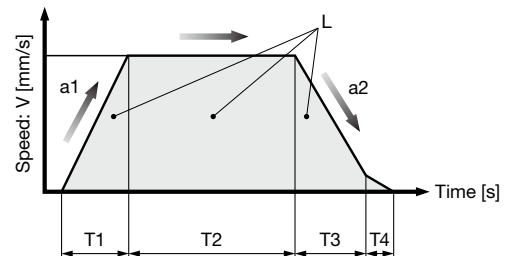

- L : Stroke [mm] ... (Operating condition)
- V : Speed [mm/s] ... (Operating condition)
- a1: Acceleration [mm/s²] ... (Operating condition)
- a2: Deceleration [mm/s²] ... (Operating condition)

- T1: Acceleration time [s] ... Time until reaching the set speed
- T2: Constant speed time [s] ... Time while the actuator is operating at a constant speed
- T3: Deceleration time [s] ... Time from the beginning of the constant speed operation to stop
- T4: Settling time [s] ... Time until positioning is completed

Selection Procedure

Pushing Control Selection Procedure



* The duty ratio is a ratio of the operation time in one cycle.

Selection Example

Operating conditions

- Mounting condition: Horizontal (pushing)
- Attachment weight: 0.2 [kg]
- Pushing force: 50 [N]
- Duty ratio: 15 [%]
- Speed: 100 [mm/s]
- Stroke: 200 [mm]

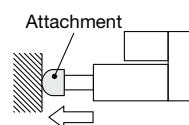

Step 1 Check the duty ratio.

<Conversion table of pushing force–duty ratio>

Select the [Pushing force] from the duty ratio while referencing the conversion table of pushing force–duty ratio.

Selection example)

Based on the table below,

- Duty ratio: 15 [%]

The pushing force set value will be 45 [%].

<Conversion table of pushing force–duty ratio>

(LE2Y16□H/Battery-less absolute)

Ambient temperature	Pushing force set value [%]	Duty ratio [%]	Continuous pushing time [min]
40°C or less	45 or less	100	No restriction

* [Pushing force set value] is one of the step data input to the controller.

* [Continuous pushing time] is the time that the actuator can continuously keep pushing.

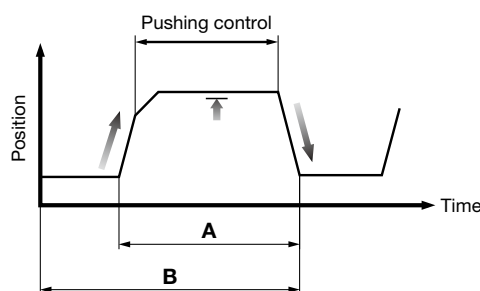

$$\text{Duty ratio} = A/B \times 100 [\%]$$

Step 2 Check the pushing force.

<Force conversion graph>

Select a model based on the pushing force set value and force while referencing the force conversion graph.

Selection example)

Based on the graph shown on the right side,

- Pushing force: 50 [N]
- Pushing force set value: 28 [%]

The LE2Y16□HB can be temporarily selected as a possible candidate.

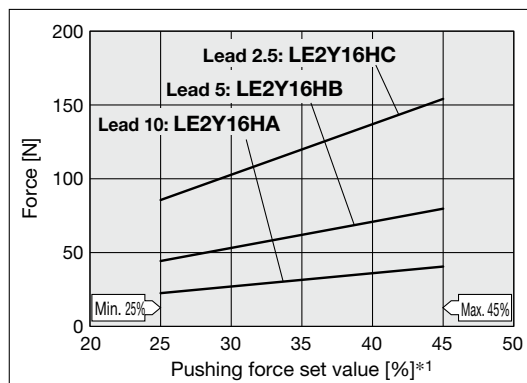

<Force conversion graph> (LE2Y16□H/Step motor)

*1 Set values for the controller

Step 3 Check the lateral load on the rod end.

<Graph of allowable lateral load on the rod end>

Confirm the allowable lateral load on the rod end of the actuator: LE2Y16□, which has been selected temporarily while referencing the graph of allowable lateral load on the rod end.

Selection example)

Based on the graph shown on the right side,

- Attachment weight: 0.2 [kg] ≈ 2 [N]
- Product stroke: 200 [mm]

The lateral load on the rod end is in the allowable range.

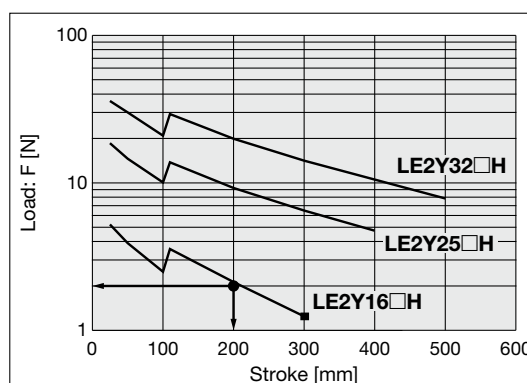

<Graph of allowable lateral load on the rod end>

Based on the above calculation result, the LE2Y16□HB-200 should be selected.

Model Selection
 LE2FS□H
 LE2FB□H
 LE2Y□H
 LE2YG□H
 LE2S(H)□H
 LE2R□H
 Auto Switch

Speed-Work Load Graph (Guide)

* The following graphs show the values when the external guide is used together.

LE2Y16□HA

Horizontal/Lead 10

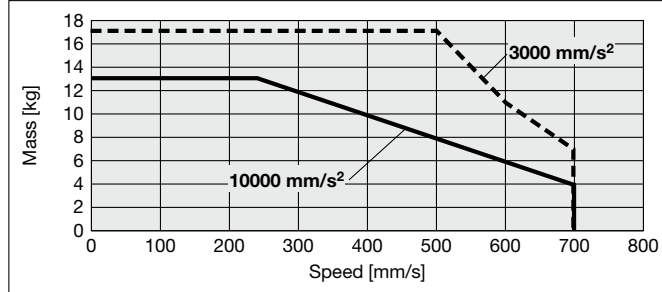

Vertical/Lead 10

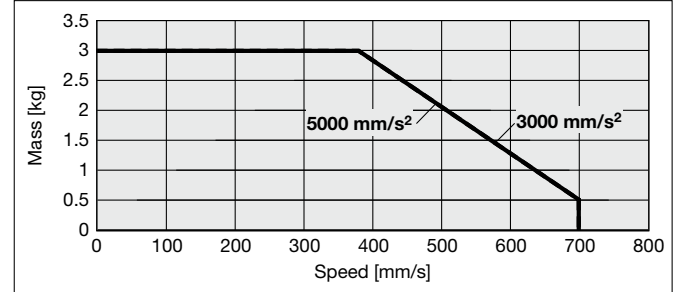

LE2Y16□HB

Horizontal/Lead 5

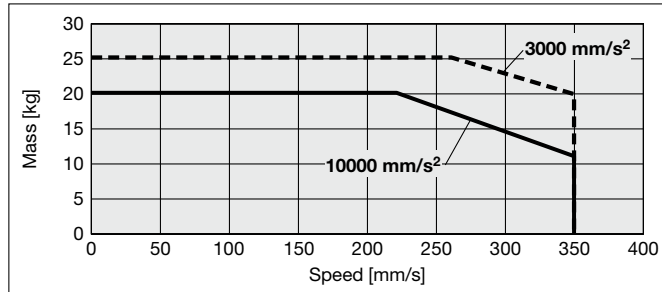

Vertical/Lead 5

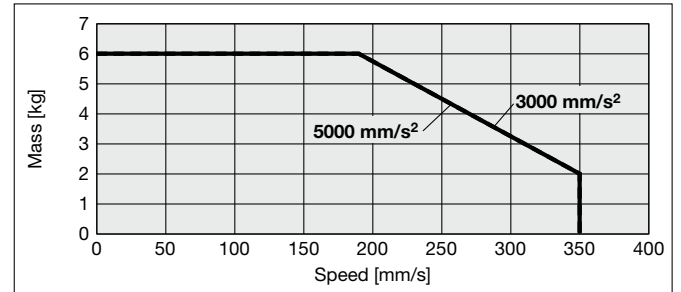

LE2Y16□HC

Horizontal/Lead 2.5

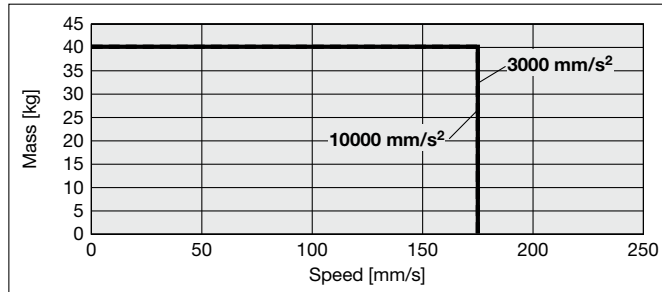

Vertical/Lead 2.5

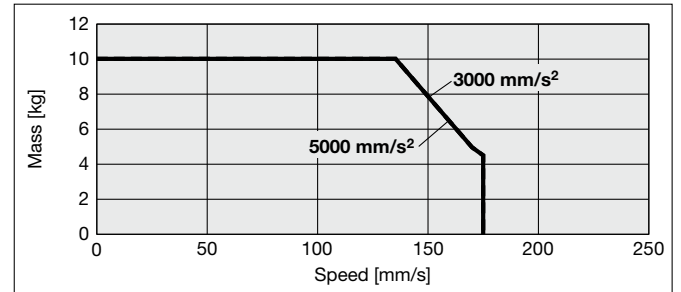

Speed-Work Load Graph (Guide)

* The following graphs show the values when the external guide is used together.

LE2Y25□HH

Horizontal/Lead 20

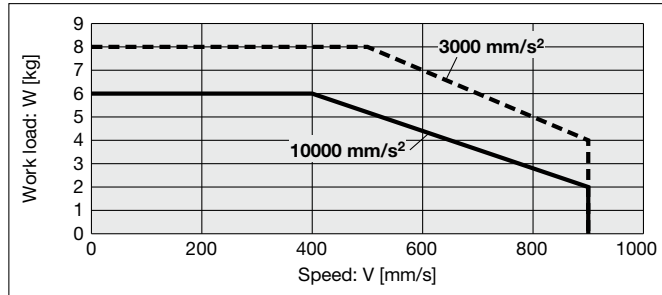

Vertical/Lead 20

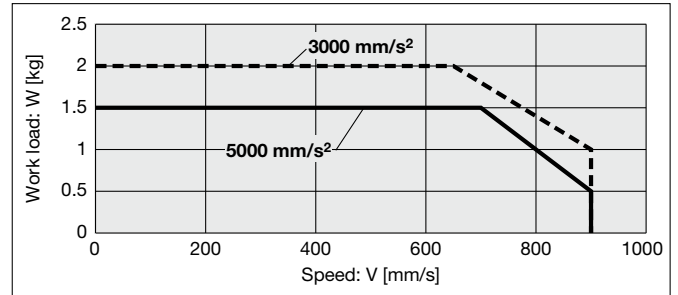

LE2Y25□HA

Horizontal/Lead 12

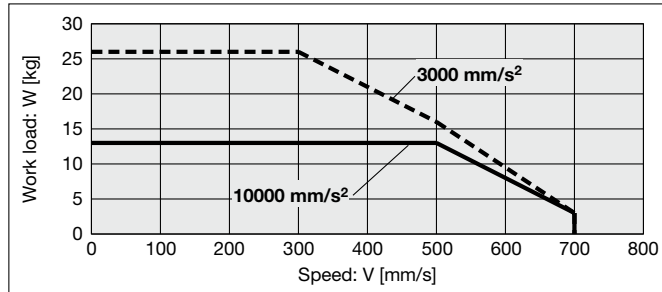

Vertical/Lead 12

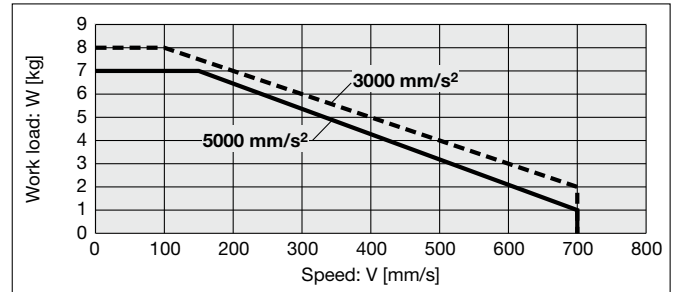

LE2Y25□HB

Horizontal/Lead 6

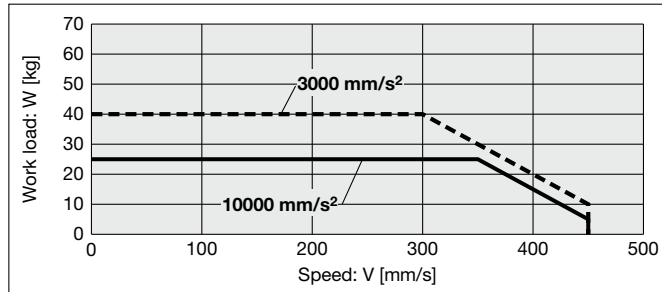

Vertical/Lead 6

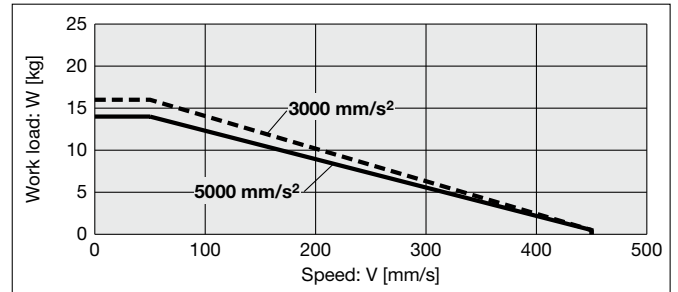

LE2Y25□HC

Horizontal/Lead 3

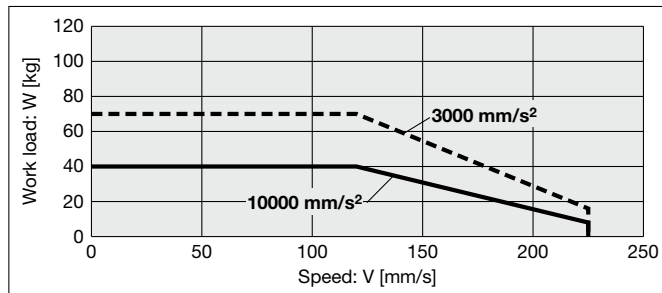

Vertical/Lead 3

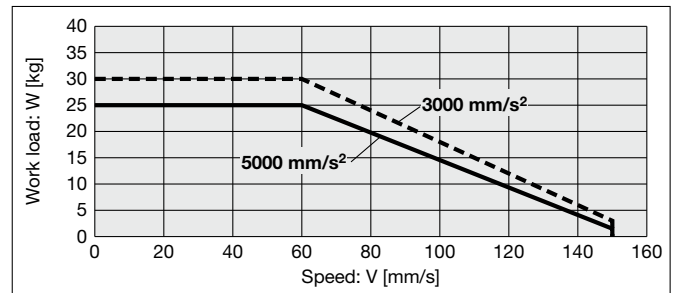

Model Selection

LE2FS□H

LE2FB□H

LE2Y□H

LE2YG□H

LE2S(H)□H

LE2R□H

Auto Switch

Speed-Work Load Graph (Guide)

* The following graphs show the values when the external guide is used together.

LE2Y32□HH

Horizontal/Lead 24

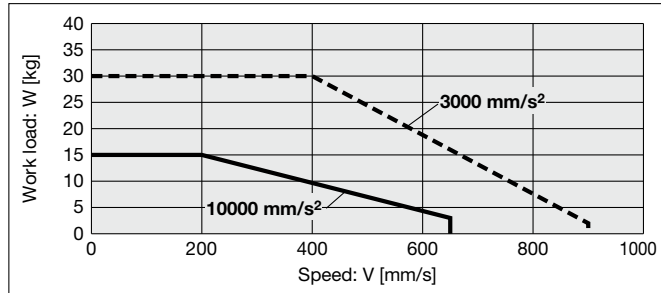

Vertical/Lead 24

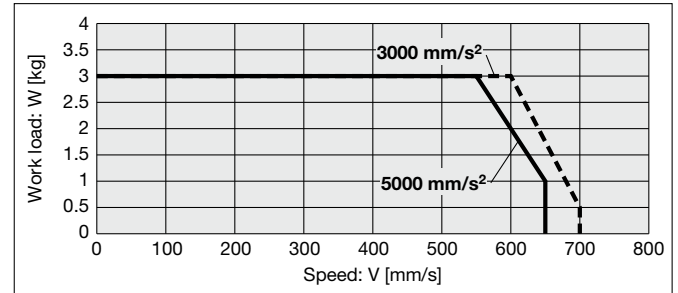

LE2Y32□HA

Horizontal/Lead 16

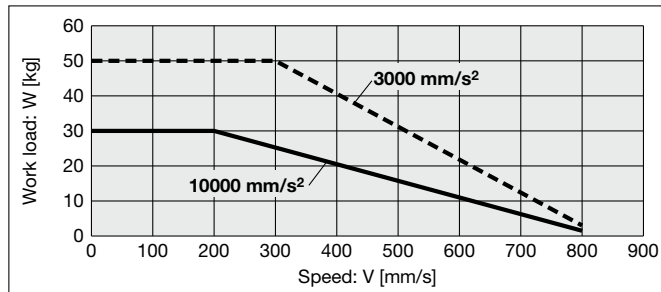

Vertical/Lead 16

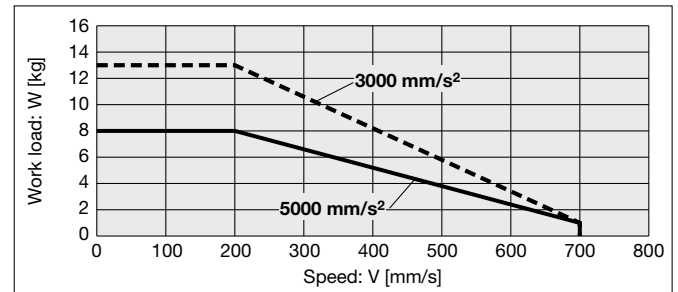

LE2Y32□HB

Horizontal/Lead 8

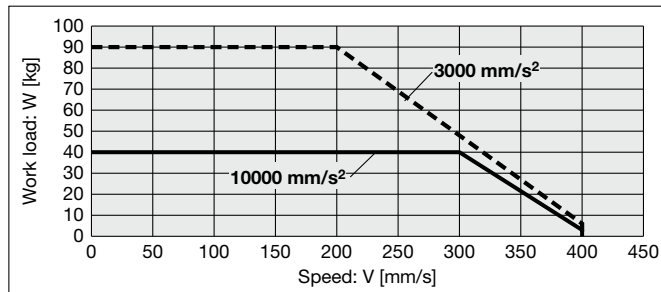

Vertical/Lead 8

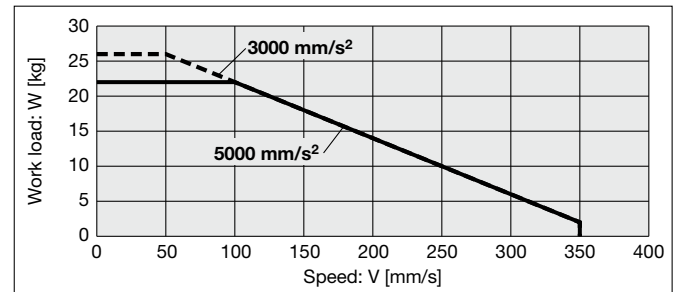

LE2Y32□HC

Horizontal/Lead 4

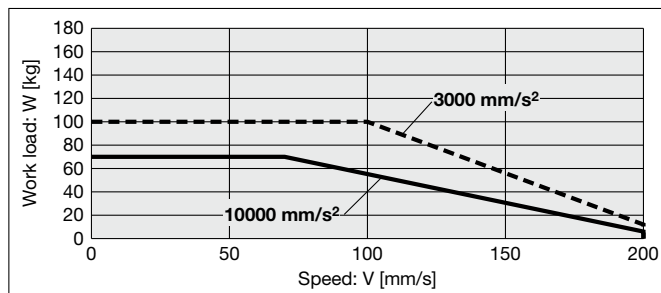

Vertical/Lead 4

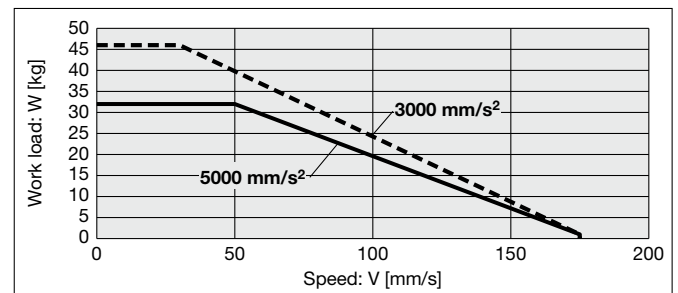

Graph of Allowable Lateral Load on the Rod End (Guide)

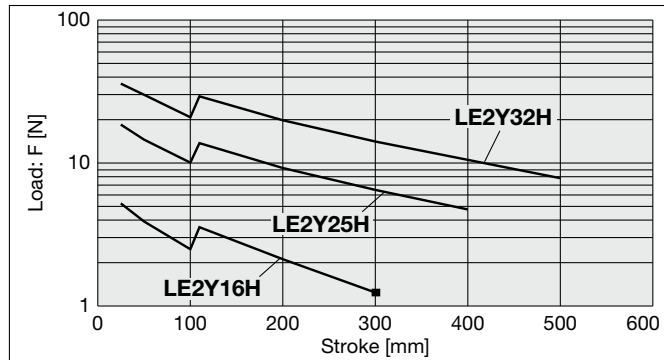

[Stroke] = [Product stroke] + [Distance from the rod end to the center of gravity of the workpiece]

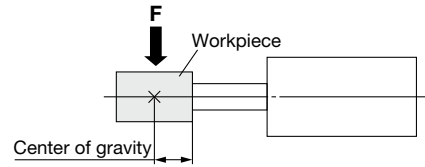

Rod Displacement: δ [mm]

Stroke \ Size	30	50	100	150	200	250	300	350	400	450	500
16	±0.4	±0.5	±0.9	±0.8	±1.1	±1.3	±1.5	—	—	—	—
25	±0.3	±0.4	±0.7	±0.7	±0.9	±1.1	±1.3	±1.5	±1.7	—	—
32	±0.3	±0.4	±0.7	±0.6	±0.8	±1.0	±1.1	±1.3	±1.5	±1.7	±1.8

* The values without a load are shown.

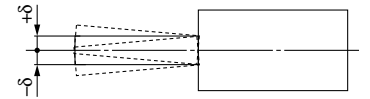

Non-rotating Accuracy of Rod

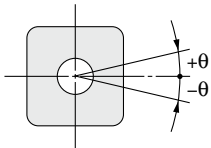

Size	Non-rotating accuracy θ
16	±1.1°
25	±0.8°
32	±0.7°

* Avoid using the electric actuator in such a way that rotational torque would be applied to the piston rod. Failure to do so may result in the deformation of the non-rotating guide, abnormal auto switch responses, play in the internal guide, or an increase in the sliding resistance.

Model Selection

LE2FS□H

LE2FB□H

LE2Y□H

LE2YG□H

LE2S(H)□H

LE2R□H

Auto Switch

Force Conversion Graph (Guide)

LE2Y16□H

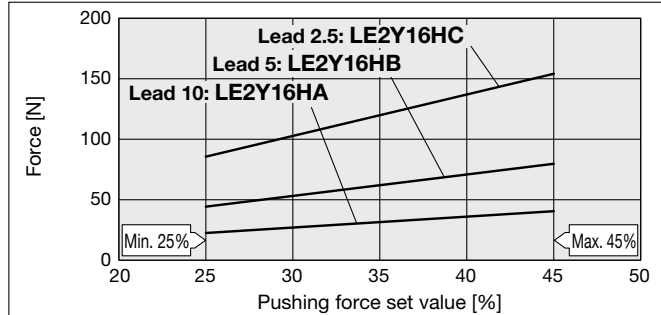

Ambient temperature	Pushing force set value [%]	Duty ratio [%]	Continuous pushing time [min]
40°C or less	45 or less	100	No restriction

LE2Y25□H

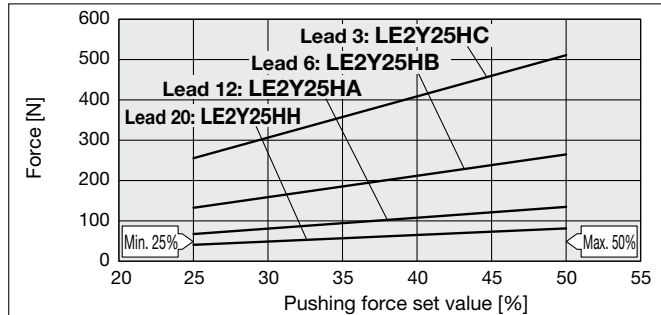

Ambient temperature	Pushing force set value [%]	Duty ratio [%]	Continuous pushing time [min]
40°C or less	50 or less	100	No restriction

LE2Y32□H

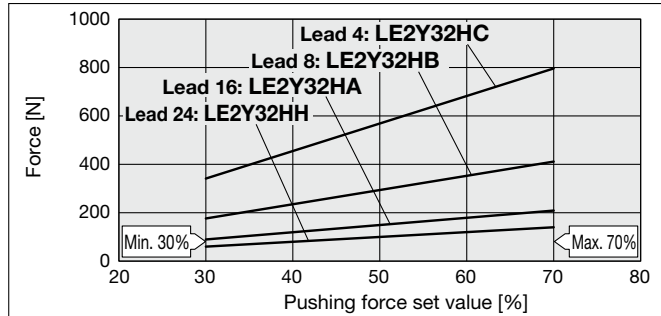

Ambient temperature	Pushing force set value [%]	Duty ratio [%]	Continuous pushing time [min]
40°C or less	70 or less	100	No restriction

<Limit Values for Pushing Force and Trigger Level in Relation to Pushing Speed>

Model	Lead	Pushing speed [mm/s]	Pushing force (Setting input value)
LE2Y16□H	A/B/C	26 to 50	30 to 45%

There is a limit to the pushing force in relation to the pushing speed. If the product is operated outside of the range (low pushing force), the completion signal [INP] may be output before the pushing operation has been completed (during the moving operation).

If operating with the pushing speed below the min. speed, please check for operating problems before using the product.

<Set Values for Vertical Upward Transfer Pushing Operations>

For vertical loads (upward), set the pushing force to the max. value shown below and operate at the work load or less.

Model	LE2Y16□H			LE2Y25□H			LE2Y32□H					
	Lead	A	B	C	H	A	B	C	H	A	B	C
Work load [kg]	1	1.5	3	1	2.5	5	10	2	4.5	9	18	
Pushing force	45%			50%			70%					

Compatible with Manifold Controller

Rod Type

LE2Y□H Series LE2Y16, 25, 32

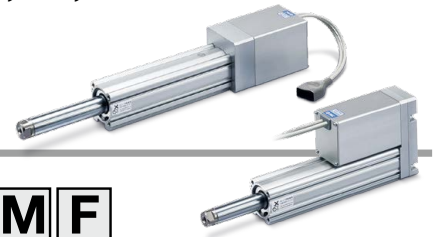

How to Order

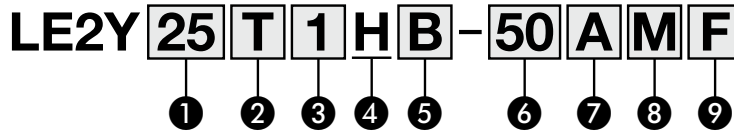

1 Size

16
25
32

2 Motor mounting position

T	Top side parallel
R	Right side parallel
L	Left side parallel
D	In-line

3 Motor cable entry direction

1	Axial
2	Right
3	Left
4	Top
5	Bottom

4 Motor type

Symbol	Type	Compatible controller
H	Battery-less absolute (Step motor 24 VDC)	JXD1

5 Lead [mm]

Symbol	LE2Y16	LE2Y25	LE2Y32
H	—	20	24
A	10	12	16
B	5	6	8
C	2.5	3	4

6 Stroke [mm]

30	30
to	to
500	500

7 Motor option

A	Without option
B	With lock

8 Rod end thread

F	Rod end female thread
M	Rod end male thread (1 rod end nut is included.)

9 Mounting

Symbol	Type	Motor mounting position	
		Parallel	In-line
S	Ends tapped Body bottom tapped	●*1	●
L	Foot bracket	●	—
F	Rod flange	●*1, *3	●
G	Head flange	●*4	—
D	Double clevis	●*2	—

Applicable Stroke Table

Size	Stroke [mm]											Manufacturable stroke range
	30	50	100	150	200	250	300	350	400	450	500	
16	●	●	●	●	●	●	●	—	—	—	—	15 to 300
25	●	●	●	●	●	●	●	●	—	—	—	15 to 400
32	●	●	●	●	●	●	●	●	●	●	●	20 to 500

The auto switches should be ordered separately. For details, refer to pages 61 and 131 to 133.

- *1 For the horizontal cantilever mounting of the rod flange or ends tapped types, use the actuator within the following stroke range.
 - LE2Y25: 200 mm or less · LE2Y32: 100 mm or less
- *2 For the mounting of the double clevis type, use the actuator within the following stroke range.
 - LE2Y16: 50 mm or less · LE2Y25: 150 mm or less · LE2Y32: 200 mm or less
- *3 The rod flange type is not available for the LE2Y16 when the stroke is 50 mm or less and the "With lock" motor option is selected. It is also not available for the LE2Y25/32 when the stroke is 30 mm or less and the "With lock" motor option is selected.
- *4 The head flange type is not available for the LE2Y32.
- * The mounting bracket is shipped together with the product but does not come assembled.

Motor Mounting Position

D: In-line

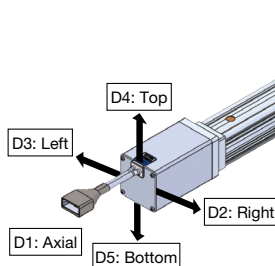

T: Top side parallel

→ T5 is not selectable.

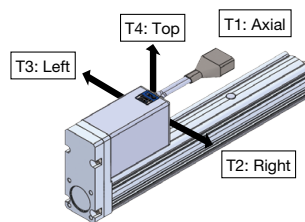

R: Right side parallel

→ R3 is not selectable.

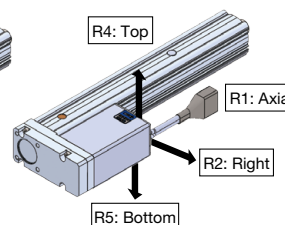

L: Left side parallel

→ L2 is not selectable.

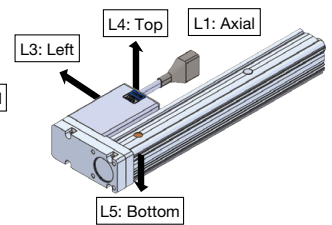

Model Selection

LE2FS□H

LE2FB□H

LE2Y□H

LE2YG□H

LE2S(H)□H

LE2R□H

Auto Switch

Specifications

Model		LE2Y16□H			LE2Y25□H				LE2Y32□H					
Actuator specifications	Stroke [mm]	30 to 300			30 to 400				30 to 500					
	Work load [kg]*1	Horizontal	17	25	40	8	26	40	70	30	50	90	100	
		Vertical	3	6	10	2	8	16	30	3	13	26	46	
	Pushing force [N]*2 *3		23 to 41	44 to 80	86 to 154	41 to 81	67 to 135	132 to 265	255 to 511	60 to 140	90 to 209	176 to 411	341 to 796	
	Speed [mm/s]	Stroke range	Up to 300	15 to 700	8 to 350	4 to 175	30 to 900	18 to 700	9 to 450	5 to 225	30 to 900	24 to 800	12 to 400	6 to 200
			350 to 400	—	—	—	30 to 900	18 to 600	9 to 300	5 to 150	30 to 900	24 to 640	12 to 320	6 to 160
			450 to 500	—	—	—	—	—	—	—	30 to 900	24 to 640	12 to 320	6 to 160
	Max. acceleration/ deceleration [mm/s ²]	Horizontal	10000											
		Vertical	5000											
	Pushing speed [mm/s]*4		1 to 50			1 to 35				1 to 30				
	Positioning repeatability [mm]		±0.02											
	Lost motion [mm]*5		0.1 or less											
	Lead [mm]		10	5	2.5	20	12	6	3	24	16	8	4	
	Impact/Vibration resistance [m/s ²]*6		50/20											
Actuation type		Ball screw + Belt (LE2Y□ (T/L/R)), /Ball screw (LE2Y□D□H)												
Guide type		Sliding bushing (Piston rod)												
Operating temperature range [°C]		5 to 40												
Operating humidity range [%RH]		90 or less (No condensation)												
Enclosure		IP40												
Electric specifications	Motor size	□28			□42				□56.4					
	Motor type	Battery-less absolute (Step motor 24 VDC)												
	Encoder	Battery-less absolute												
	Power supply voltage [V]	24 VDC ±10%												
Lock unit specifications	Power [W]*7 *8	Max. power 74			Max. power 71				Max. power 93					
	Type*9	Non-magnetizing lock												
	Holding force [N]	29	59	98	20	78	157	294	29	127	255	451		
	Power [W]*8	4			8				8					
Power supply voltage [V]		24 VDC ±10%												

*1 Horizontal: Please use an external guide (friction coefficient: 0.1 or less). The work load shows the maximum value. The actual work load and transfer speed change according to the condition of the external guide.

For the speed, acceleration, and duty ratio according to the work load, check the "Speed-Work Load Graph" in the catalog.

Vertical: If the rod orientation is vertical or radial load is applied to the rod, please use an external guide (friction coefficient: 0.1 or less). The work load represents the maximum value. The actual work load and transfer speed change according to the condition of the external guide.

For the speed, acceleration, and duty ratio according to the work load, check the "Speed-Work Load Graph" in the catalog.

The values shown in () are the max. acceleration/deceleration.

Set the acceleration/deceleration speed to 10000 [mm/s²] or less for the horizontal direction and 5000 [mm/s²] or less for the vertical direction.

*2 Pushing force accuracy is ±20% (F.S.).

*3 The pushing force set values for LE2Y16□H are 25% to 45%, for LE2Y25□H are 25% to 50%, and for LE2Y32□H are 30% to 70%.

The pushing force values change according to the duty ratio and pushing speed. Check the "Force Conversion Graph" on page 49.

*4 The allowable speed for pushing operation. When push conveying a workpiece, operate at the vertical work load or less.

*5 A reference value for correcting errors in reciprocal operation

*6 Impact resistance: No malfunction occurred when the actuator was tested with a drop tester in both an axial direction and a perpendicular direction to the lead screw. (The test was performed with the actuator in the initial state.)

Vibration resistance: No malfunction occurred in a test ranging between 45 to 2000 Hz. The test was performed in both an axial direction and a perpendicular direction to the lead screw. (The test was performed with the actuator in the initial state.)

*7 Indicates the max. power during operation (excluding the controller). This value can be used for the selection of the power supply.

*8 For an actuator with lock, add the power for the lock.

*9 With lock only

Weight

Top/Right/Left Side Parallel Motor

Series	LE2Y16						
Stroke [mm]	30	50	100	150	200	250	300
Product weight [kg]	0.80	0.84	0.96	1.11	1.23	1.34	1.45
Additional weight with lock [kg]	0.19						

Series	LE2Y25									LE2Y32										
Stroke [mm]	30	50	100	150	200	250	300	350	400	30	50	100	150	200	250	300	350	400	450	500
Product weight [kg]	1.51	1.58	1.76	2.05	2.22	2.40	2.58	2.76	2.94	2.50	2.61	2.90	3.38	3.67	3.96	4.25	4.53	4.82	5.11	5.40
Additional weight with lock [kg]	0.33									0.64										

In-line Motor

Series	LE2Y16						
Stroke [mm]	30	50	100	150	200	250	300
Product weight [kg]	0.76	0.80	0.91	1.07	1.18	1.30	1.41
Additional weight with lock [kg]	0.19						

Series	LE2Y25									LE2Y32										
Stroke [mm]	30	50	100	150	200	250	300	350	400	30	50	100	150	200	250	300	350	400	450	500
Product weight [kg]	1.43	1.50	1.68	1.97	2.14	2.32	2.50	2.68	2.86	2.38	2.49	2.78	3.26	3.54	3.83	4.12	4.41	4.70	4.99	5.27
Additional weight with lock [kg]	0.34									0.63										

Additional Weight

Size		16	25	32
Rod end male thread	Male thread	0.01	0.03	0.03
	Nut	0.01	0.02	0.02
Foot bracket (2 sets including mounting bolt)		0.06	0.08	0.14
Rod flange (including mounting bolt)		0.13	0.17	0.2
Head flange (including mounting bolt)				
Double clevis (including pin, retaining ring, and mounting bolt)		0.08	0.16	0.22

Model Selection

LE2FS□H

LE2FB□H

LE2Y□H

LE2YG□H

LE2S(H)□H

LE2R□H

Auto Switch

Dimensions: Top Side Parallel Motor

LE2Y16(T/R/L)H

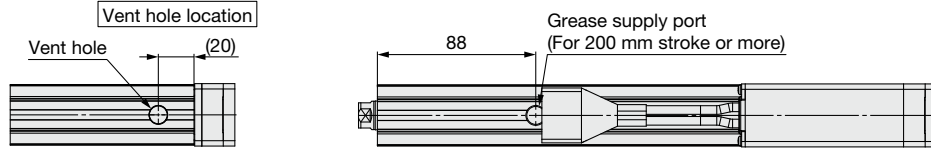

<Rod operating range>

- *1 The range of movement of the rod according to the movement instructions.
Make sure that workpieces mounted on the rod do not interfere with other workpieces or the facilities around the rod.
- *2 Indicates the factory default origin position (0 mm)
- *3 [] refers to when the rotation direction reference is changed.

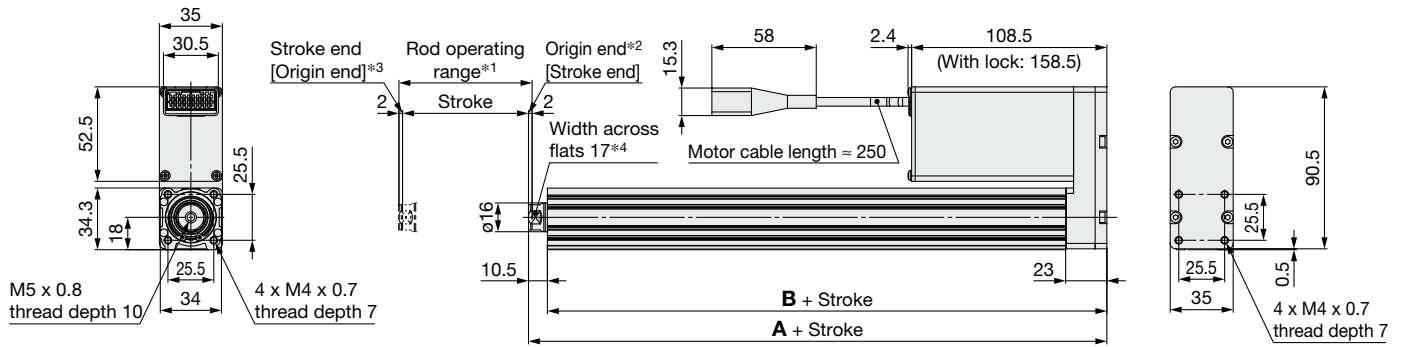

Rod end male thread

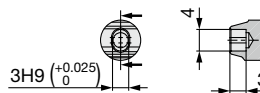
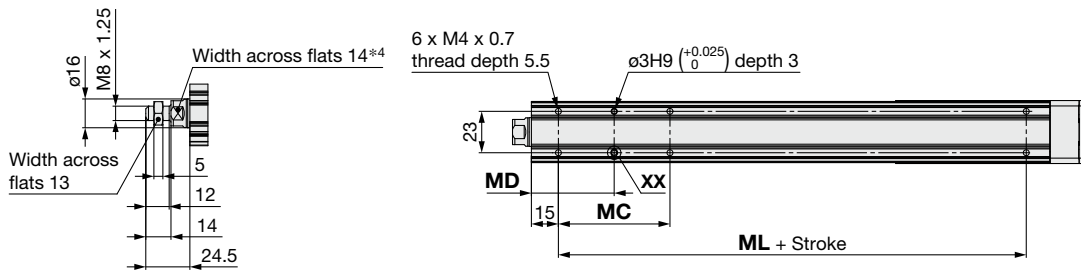

XX (2:1)

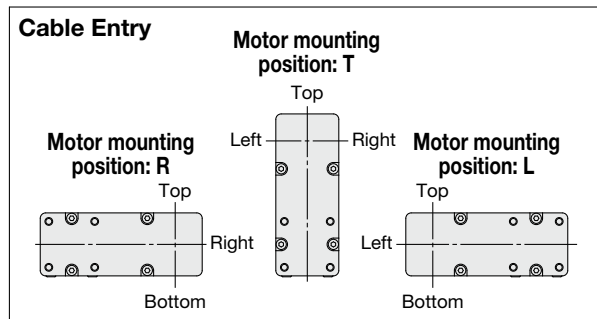

- *4 The direction of the rod end width across flats is different for each single unit, so it is not always the same as the direction in the drawing.
- * For details on the mounting bracket dimensions, refer to the catalog.
- * This illustration shows the motor mounting position for the top side parallel type. Refer to the catalog for detailed dimensions of the right/left side parallel type.
- * The axial cable entry direction is shown.

Dimensions

Stroke	A	B	MC	MD	ML
30	101.5	91	17	23.5	40
50, 100			32	31	
150, 200, 250, 300	121.5	111	62	46	60

Dimensions: Top Side Parallel Motor

LE2Y25(T/R/L)H

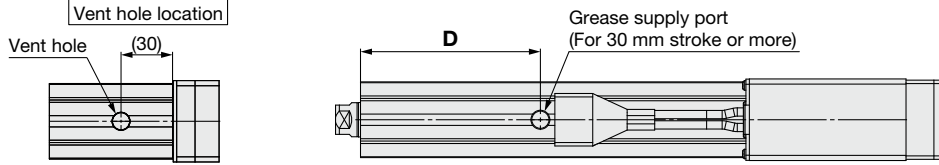

<Rod operating range>
 *1 The range of movement of the rod according to the movement instructions.
 Make sure that workpieces mounted on the rod do not interfere with other workpieces or the facilities around the rod.
 *2 Indicates the factory default origin position (0 mm)
 *3 [] refers to when the rotation direction reference is changed.

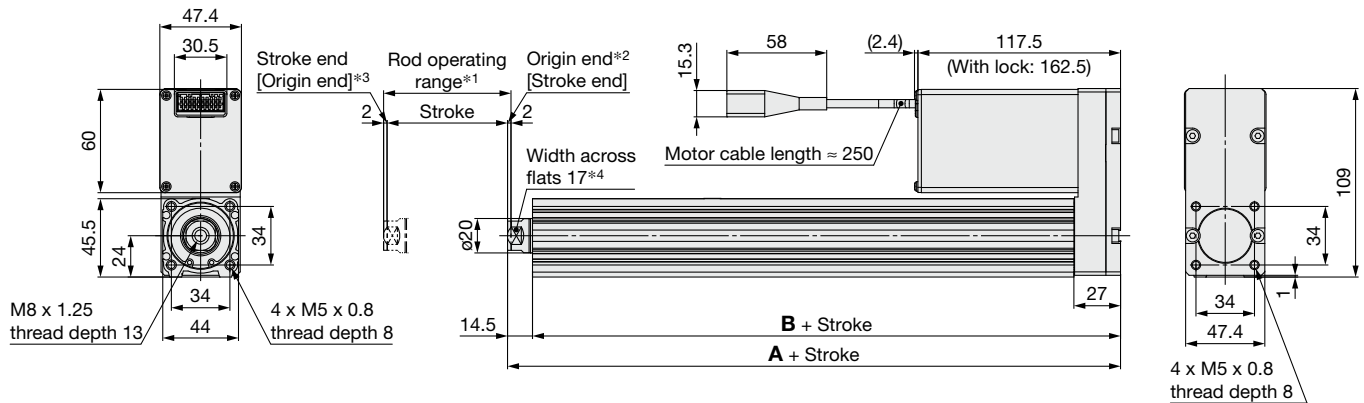

Rod end male thread

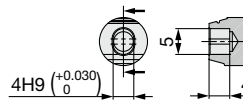
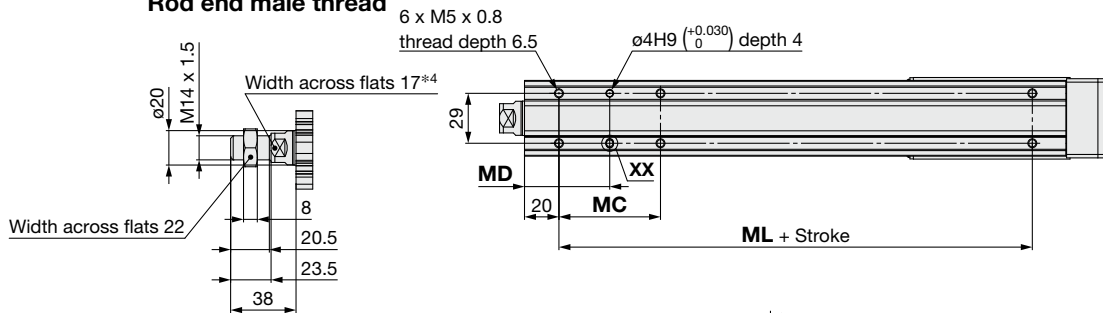

XX (2:1)

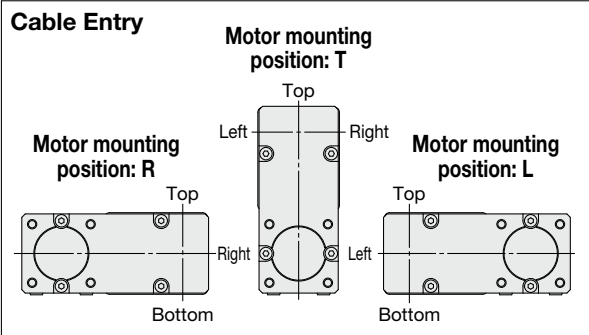

*4 The direction of the rod end width across flats is different for each single unit, so it is not always the same as the direction in the drawing.
 * For details on the mounting bracket dimensions, refer to the catalog.
 * This illustration shows the motor mounting position for the top side parallel type. Refer to the catalog for detailed dimensions of the right/left side parallel type.
 * The axial cable entry direction is shown.

Dimensions

Stroke	A	B	D	MC	MD	ML
30	131	116.5	74.5	24	32	50
50, 100			79.5	42	41	
150, 200	156	141.5	104.5	59	49.5	75
250, 300, 350, 400				76	58	

Dimensions: Top Side Parallel Motor

LE2Y32(T/R/L)H

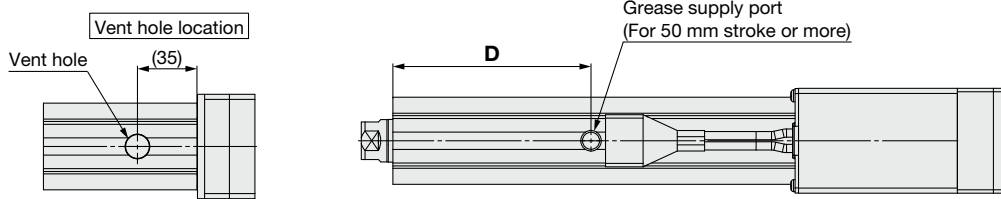

<Rod operating range>

- *1 The range of movement of the rod according to the movement instructions.
Make sure that workpieces mounted on the rod do not interfere with other workpieces or the facilities around the rod.
- *2 Indicates the factory default origin position (0 mm)
- *3 [] refers to when the rotation direction reference is changed.

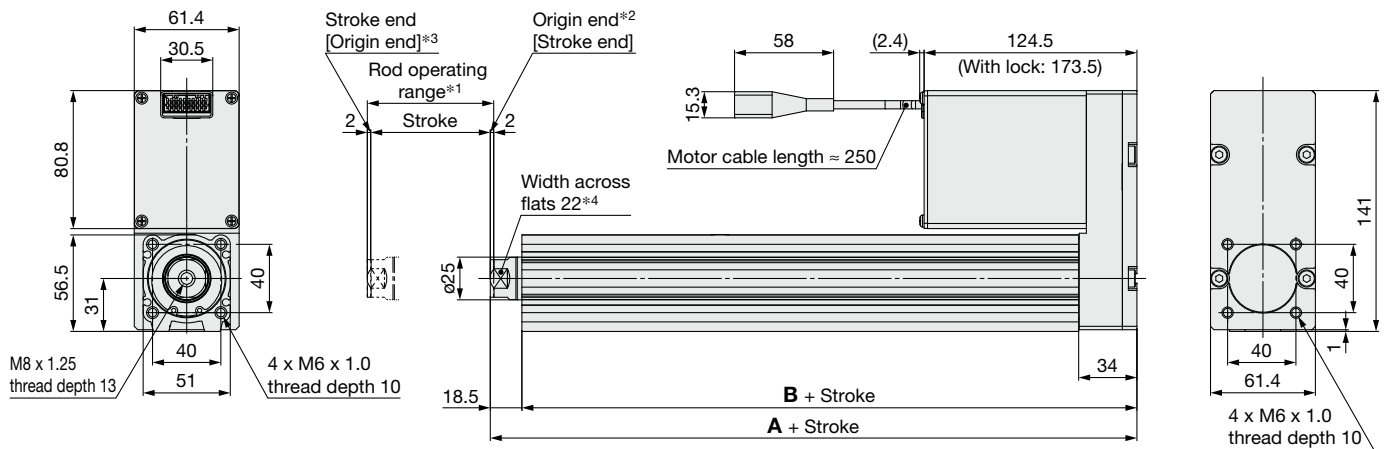

Rod end male thread

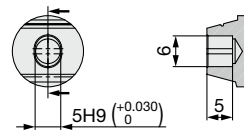
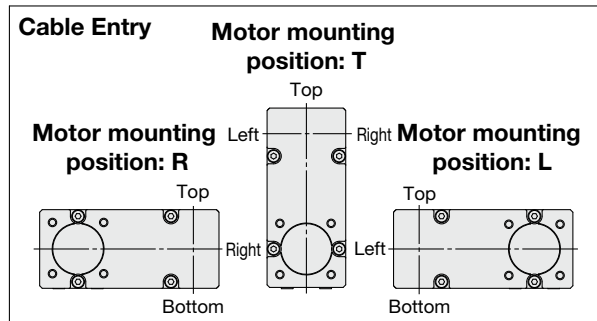
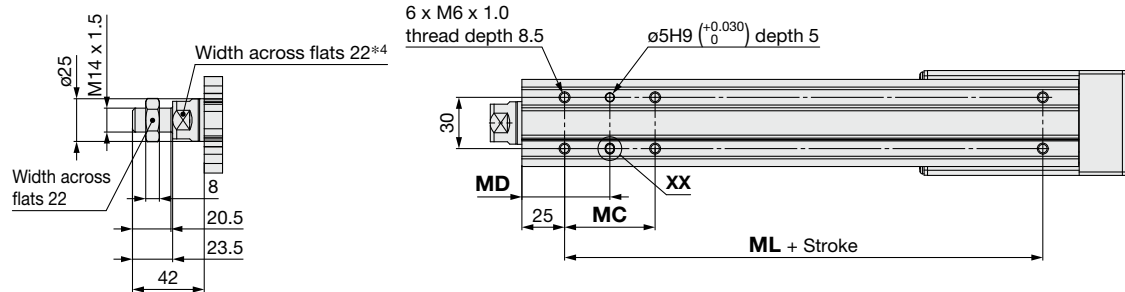

XX (2:1)

- *4 The direction of the rod end width across flats is different for each single unit, so it is not always the same as the direction in the drawing.
- * For details on the mounting bracket dimensions, refer to the catalog.
- * This illustration shows the motor mounting position for the top side parallel type. Refer to the catalog for detailed dimensions of the right/left side parallel type.
- * The axial cable entry direction is shown.

Dimensions

[mm]

Stroke	A	B	D	MC	MD	ML
30	148.5	130	—	22	36	50
50, 100			86	36	43	
150, 200	178.5	160	116	53	51.5	80
250, 300, 350, 400				70	60	

Dimensions: In-line Motor

LE2Y16DH

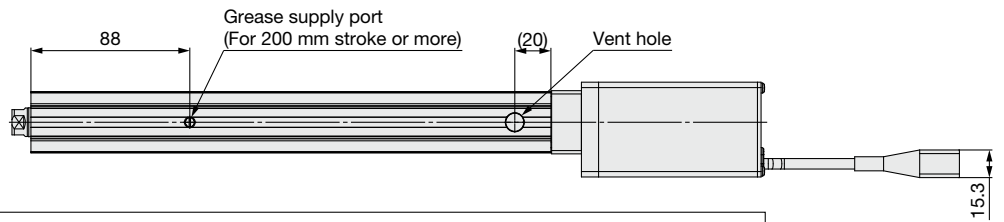

<Rod operating range>
 *1 The range of movement of the rod according to the movement instructions.
 Make sure that workpieces mounted on the rod do not interfere with other workpieces or the facilities around the rod.
 *2 Indicates the factory default origin position (0 mm)
 *3 [] refers to when the rotation direction reference is changed.

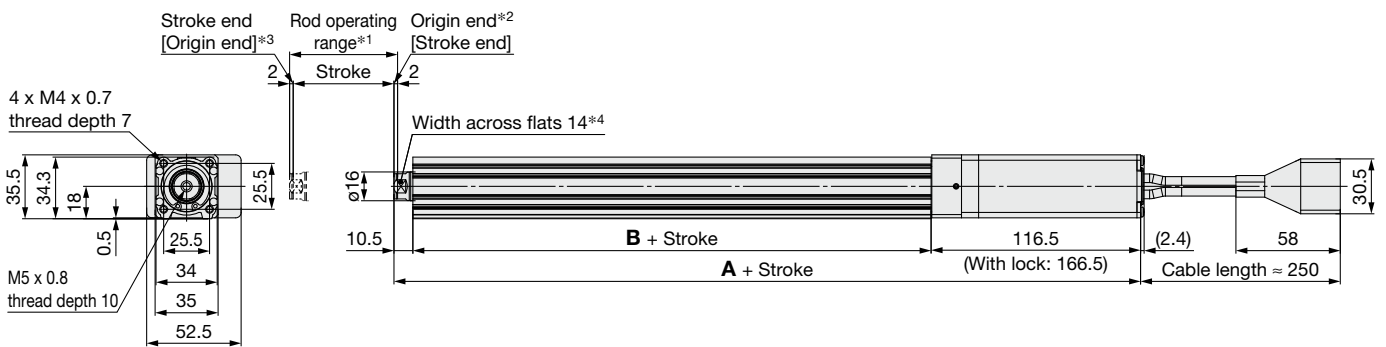

Rod end male thread

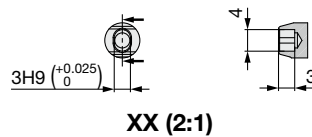
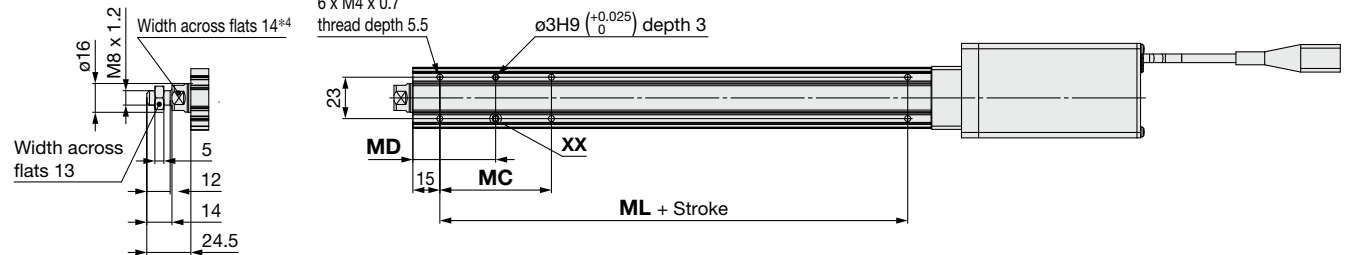

*4 The direction of the rod end width across flats is different for each single unit, so it is not always the same as the direction in the drawing.
 * For details on the mounting bracket dimensions, refer to the catalog.
 * The axial cable entry direction is shown.

Dimensions

Stroke	A		B	MC	MD	ML
	Without lock	With lock				
30	195	245	68	17	23.5	40
50, 100				32	31	
150, 200, 250, 300	215	265	88	62	46	60

Model Selection

LE2FS□H

LE2FB□H

LE2Y□H

LE2YG□H

LE2S(H)□H

LE2R□H

Auto Switch

Dimensions: In-line Motor

LE2Y25DH

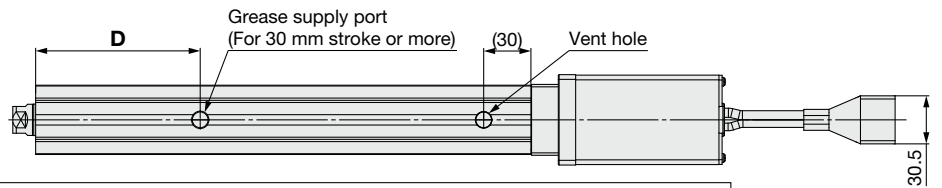

<Rod operating range>
 *1 The range of movement of the rod according to the movement instructions.
 Make sure that workpieces mounted on the rod do not interfere with other workpieces or the facilities around the rod.
 *2 Indicates the factory default origin position (0 mm)
 *3 [] refers to when the rotation direction reference is changed.

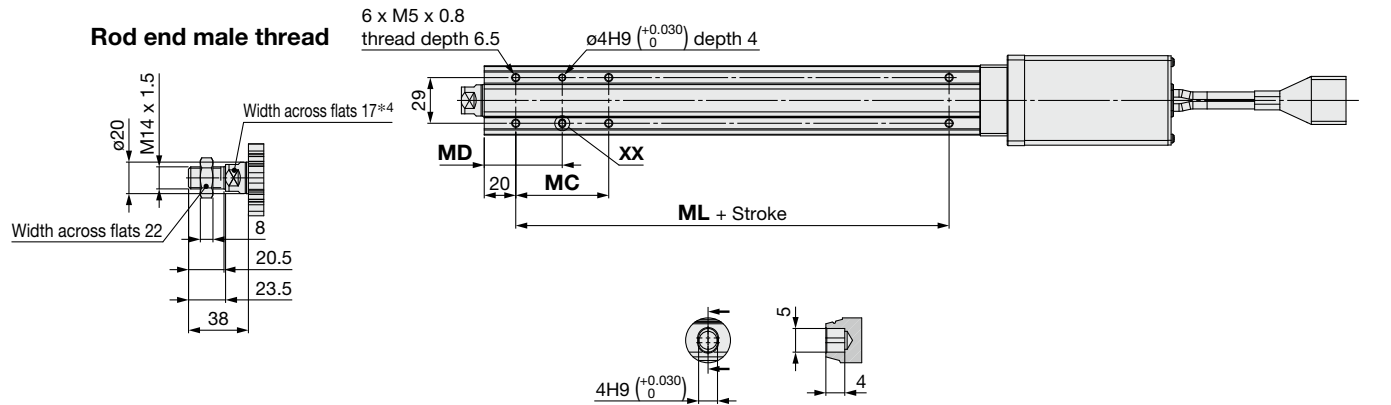
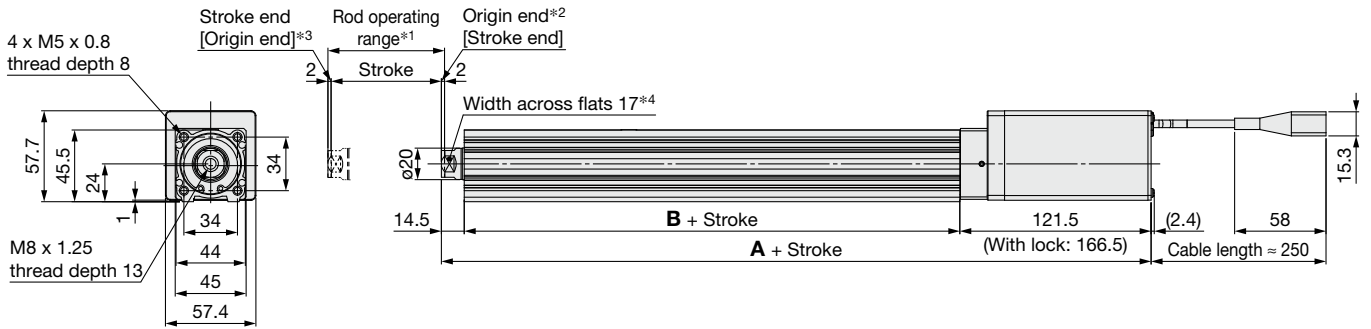

XX (2:1)

*4 The direction of the rod end width across flats is different for each single unit, so it is not always the same as the direction in the drawing.
 * For details on the mounting bracket dimensions, refer to the catalog.
 * The axial cable entry direction is shown.

Dimensions

Stroke	A		B	D	MC	MD	ML
	Without lock	With lock					
30	225.5	270.5	89.5	74.5	24	32	50
50, 100	250.5	295.5	114.5	79.5	42	41	
150, 200	250.5	295.5	114.5	104.5	59	49.5	75
250, 300, 350, 400	250.5	295.5	114.5	104.5	76	58	

Dimensions: In-line Motor

LE2Y32DH

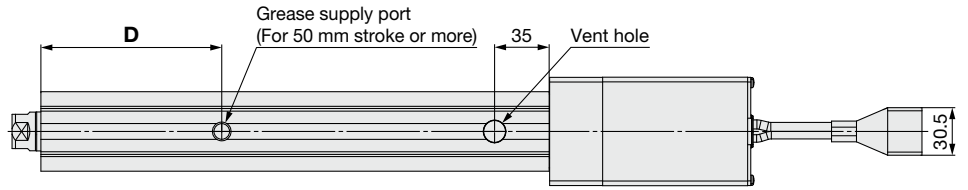

<Rod operating range>

- *1 The range of movement of the rod according to the movement instructions.
Make sure that workpieces mounted on the rod do not interfere with other workpieces or the facilities around the rod.
- *2 Indicates the factory default origin position (0 mm)
- *3 [] refers to when the rotation direction reference is changed.

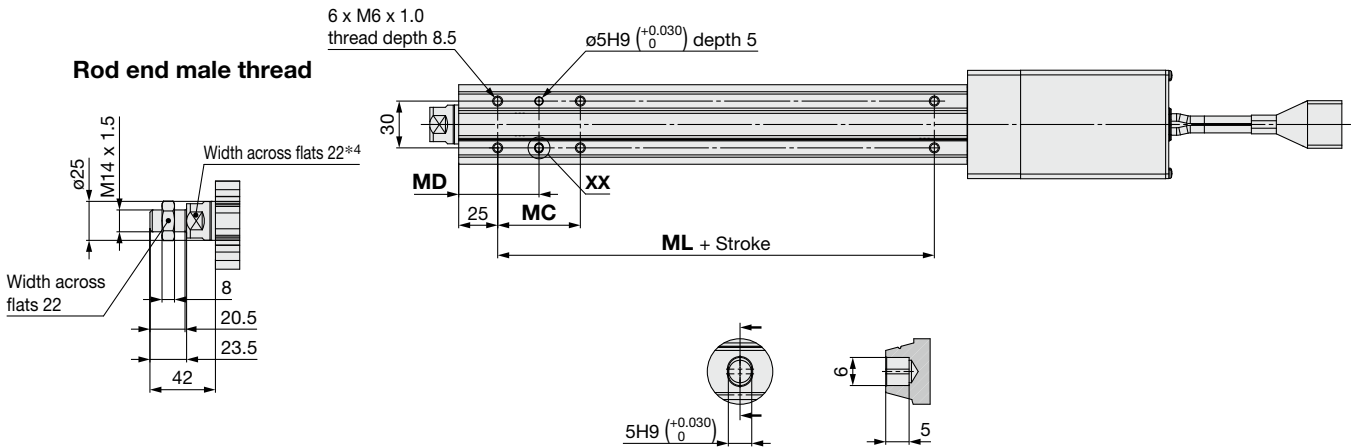
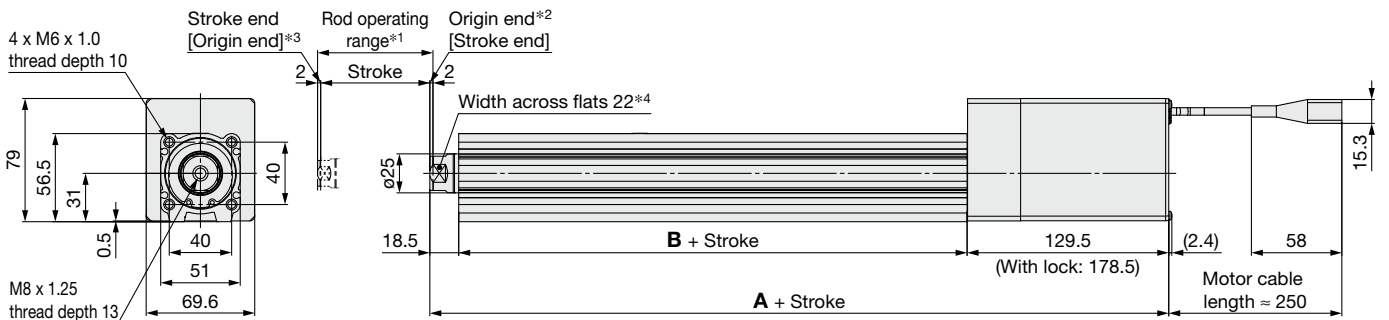

XX (2:1)

- *4 The direction of the rod end width across flats is different for each single unit, so it is not always the same as the direction in the drawing.
- * For details on the mounting bracket dimensions, refer to the catalog.
- * The axial cable entry direction is shown.

Dimensions

Stroke	A		B	D	MC	MD	ML
	Without lock	With lock					
30				—	22	36	50
50, 100	244	293	96	86	36	43	
150, 200	274	323	126	116	53	51.5	80
250, 300, 350, 400					70	60	

Model Selection

LE2FS□H

LE2FB□H

LE2Y□H

LE2YG□H

LE2S(H)□H

LE2R□H

Auto Switch

Dimensions

End male thread: LE2Y¹⁶25□H^A□B□C³²-□□M□

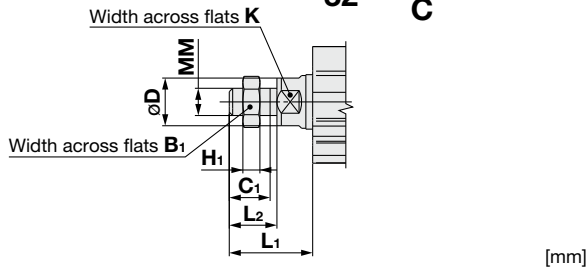

Size	B ₁	C ₁	øD	H ₁	K	L ₁	L ₂	MM
16	13	12	16	5	14	24.5	14	M8 x 1.25
25	22	20.5	20	8	17	38	23.5	M14 x 1.5
32	22	20.5	25	8	22	42	23.5	M14 x 1.5

* The L₁ measurement is when the unit is in the original position. At this position, 2 mm at the end.

* Refer to the **Web Catalog** for details on the rod end nut and mounting bracket.
 * Refer to the specific product precautions (“Handling”) in the **Web Catalog** when mounting end brackets such as knuckle joint or workpieces.

Foot bracket: LE2Y¹⁶25□H^A□B□C³²-□□□L

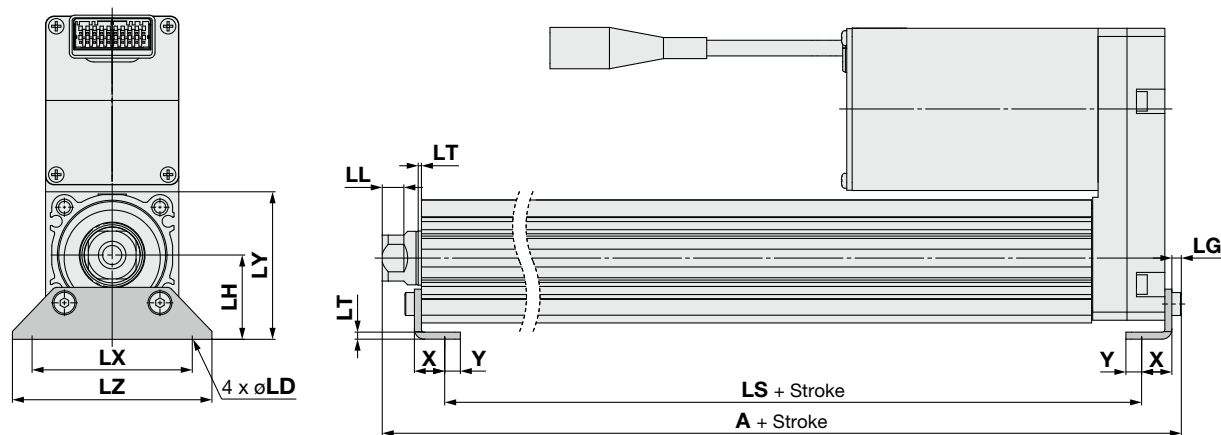

Outward mounting

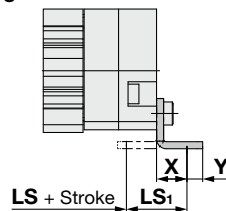

Included parts
 · Foot bracket
 · Body mounting bolt

Foot Bracket

Size	Stroke range [mm]	A	LS	LS ₁	LL	LD	LG	LH	LT	LX	LY	LZ	X	Y
16	30 to 100	106.1	76.7	16.1	5.4	6.6	2.8	24	2.3	48	40.3	62	9.2	5.8
	101 to 300	126.1	96.7											
25	30 to 100	136.6	98.8	19.8	8.4	6.6	3.5	30	2.6	57	51.5	71	11.2	5.8
	101 to 400	161.6	123.8											
32	30 to 100	155.7	114	19.2	11.3	6.6	4	36	3.2	76	61.5	90	11.2	7
	101 to 500	185.7	144											

Material: Carbon steel (Chromating)

* The A measurement is when the unit is in the original position. At this position, 2 mm at the end.

* When the motor mounting is the right or left side parallel type, the head side foot bracket should be mounted outward.

Dimensions

Rod flange: LE2Y16□HB-□□□F

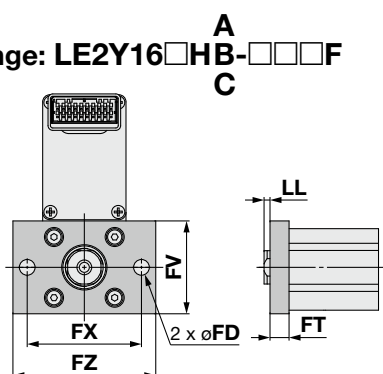

Head flange: LE2Y16HB-□□□G

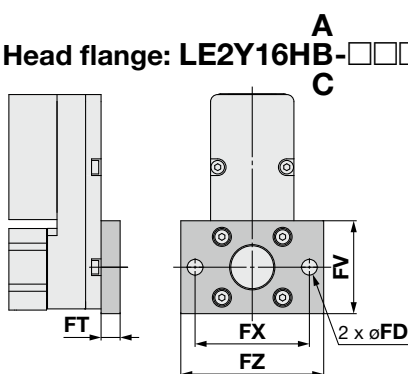

Rod flange: LE2Y²⁵/₃₂□H^A/_B-□□□F

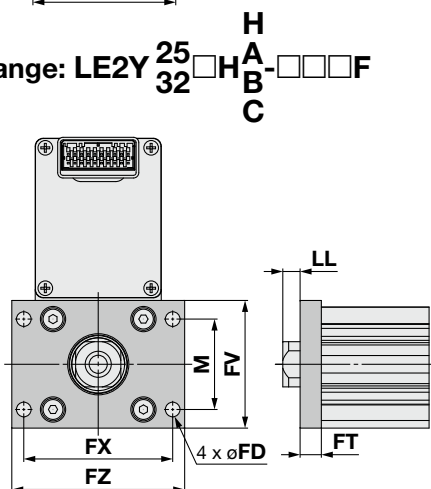

Head flange: LE2Y²⁵/₃₂□H^A/_B-□□□G

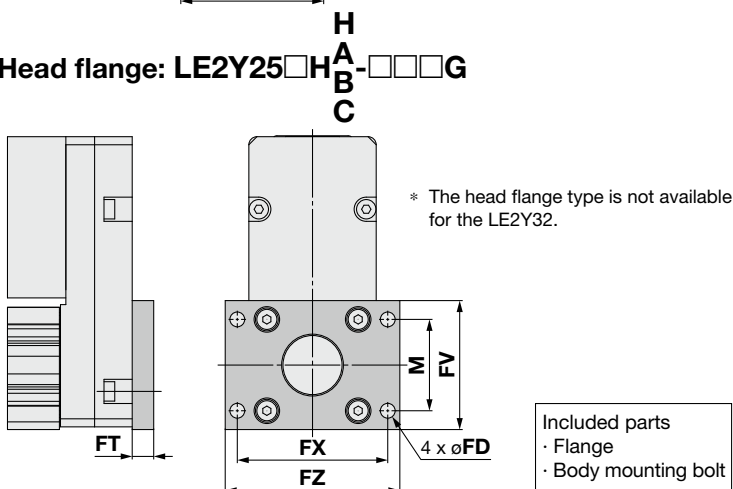

Included parts
· Flange
· Body mounting bolt

Double clevis: LE2Y16HB-□□□D

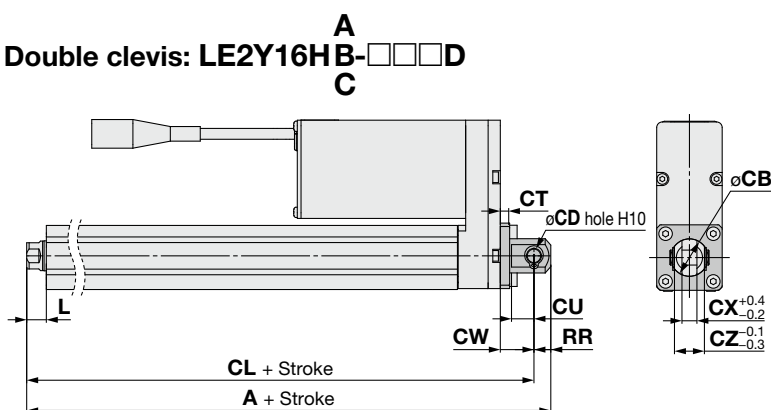

Rod/Head Flange [mm]

Size	FD	FT	FV	FX	FZ	LL	M
16	6.6	8	39	48	60	2.5	—
25	5.5	8	48	56	65	6.5	34
32	5.5	8	54	62	72	10.5	40

Material: Carbon steel (Nickel plating)

Included parts
· Double clevis
· Clevis pin
· Body mounting bolt
· Retaining ring

* Refer to the **Web Catalog** for details on the rod end nut and mounting bracket.

Double clevis: LE2Y²⁵/₃₂□H^A/_B-□□□D

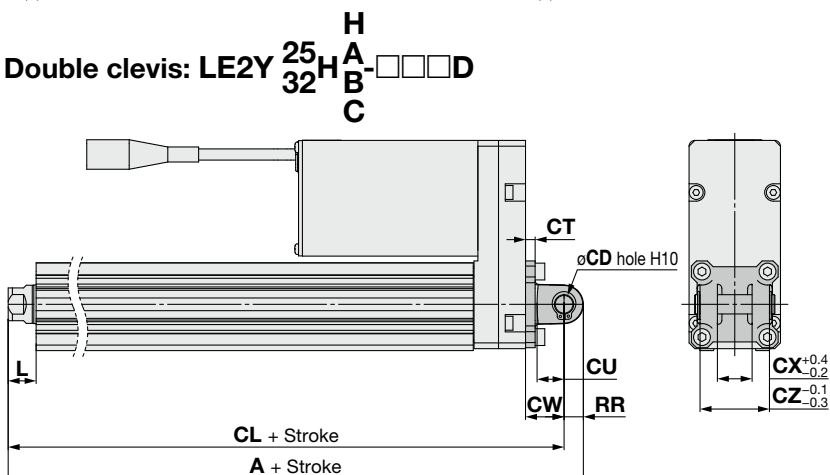

Double Clevis [mm]

Size	Stroke range [mm]	A	CL	CB	CD	CT
16	30 to 100	128	119	20	8	5
	101 to 200	160.5	150.5	—	10	5
25	30 to 100	180.5	170.5	—	10	6
	101 to 200	210.5	200.5	—	10	6

Size	Stroke range [mm]	CU	CW	CX	CZ	L	RR
16	30 to 100	12	18	8	16	10.5	9
	101 to 200	14	20	18	36	14.5	10
25	30 to 100	14	22	18	36	18.5	10
	101 to 200	14	22	18	36	18.5	10

Material: Cast iron (Coating)

* The A and CL measurements are when the unit is in the original position. At this position, 2 mm at the end.

For the models and dimensions of the mounting bracket and simple joint bracket, refer to the **Web Catalog** for the LEY series.

Model Selection
 LE2FS□H
 LE2FB□H
 LE2Y□H
 LE2YG□H
 LE2S(H)□H
 LE2R□H
 Auto Switch

LE2Y□H Series

Auto Switch Mounting

Auto Switch Proper Mounting Position

Applicable auto switch: D-M9□(V), D-M9□E(V), D-M9□W(V), D-M9□A(V)

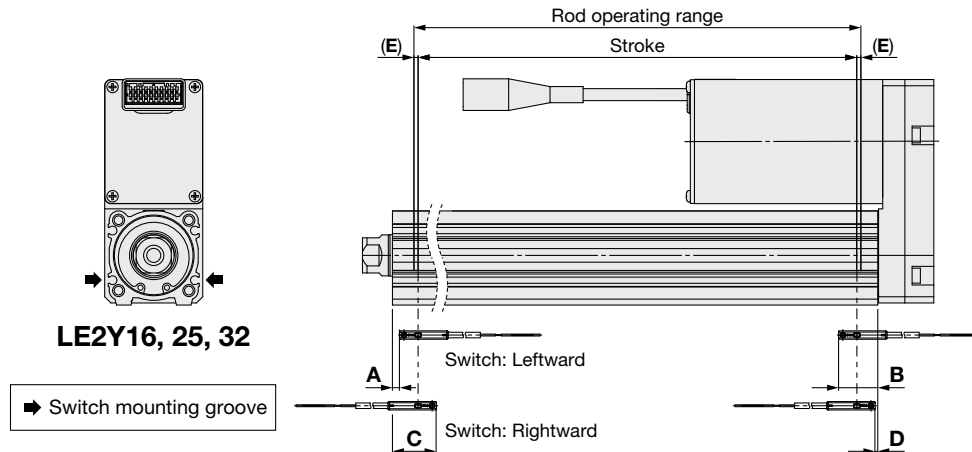

Size	Stroke range	Auto switch position				Return to origin distance	Operating range
		Leftward mounting		Rightward mounting			
		A	B	C	D		
16	30 to 100	21.5	46.5	33.5	34.5	(2)	2.9
	105 to 300	41.5		53.5			
25	30 to 100	27	62.5	39	50.5	(2)	4.2
	105 to 400	52		64			
32	30 to 100	30.5	65.5	42.5	53.5	(2)	4.9
	105 to 500	60.5		72.5			

- * The values in the table above are to be used as a reference when mounting auto switches for stroke end detection. Adjust the auto switch after confirming the operating conditions in the actual setting.
- * An auto switch cannot be mounted on the same side as a motor.
- * Since the operating range is provided as a guideline including hysteresis, it cannot be guaranteed (assuming approx. $\pm 30\%$ dispersion). It may change substantially depending on the ambient environment.
- * For the LE2YG guide rod type, auto switches cannot be mounted behind the guide attachment (in the bottom groove on the side of the rod that sticks out). In addition, auto switches with perpendicular electrical entries cannot be used.

Auto Switch Mounting

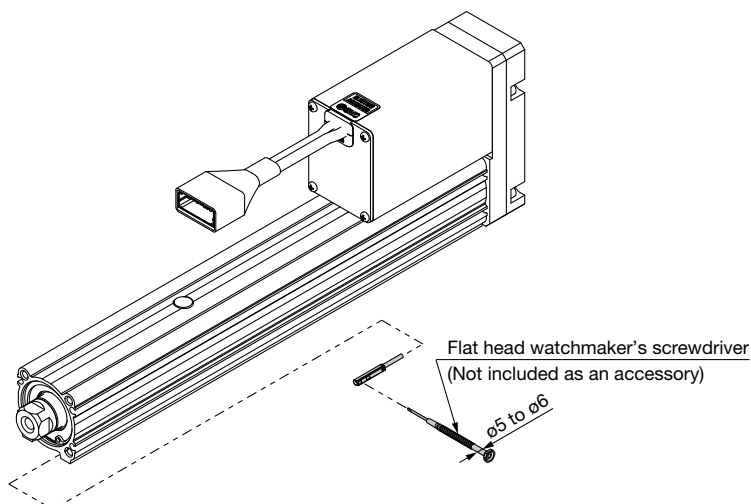

Tightening Torque for Auto Switch Mounting Screw [N·m]

Auto switch model	Tightening torque
D-M9□(V) D-M9□E(V) D-M9□W(V)	0.05 to 0.15
D-M9□A(V)	0.05 to 0.10

- * When tightening the auto switch mounting screw (included with the auto switch), use a watchmaker's screwdriver with a handle diameter of 5 to 6 mm.

Guide Rod Type

LE2YG□H Series

p. 63

Battery-less Absolute (Step Motor 24 VDC)

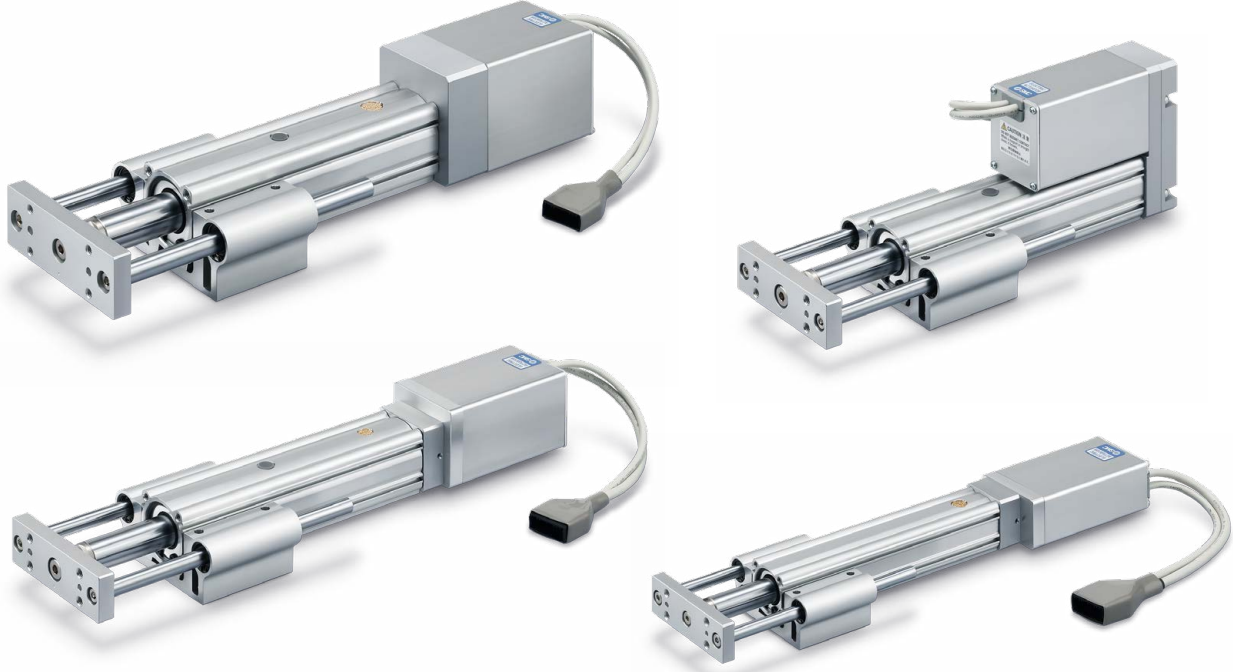

Model Selection

LE2FS□H

LE2FB□H

LE2Y□H

LE2YG□H

LE2S(H)□H

LE2R□H

Auto Switch

Model Selection



Moment Load Graph

Selection conditions

Mounting position		Vertical		Horizontal	
Max. speed [mm/s]		"Speed-Work Load Graph"		200 or less	Over 200
Bearing	Sliding bearing	Graphs ①, ②		Graphs ⑤, ⑥	Graphs ⑦, ⑧
	Ball bushing bearing	Graphs ③, ④		Graphs ⑨, ⑩	Graphs ⑪, ⑫

Vertical Mounting, Sliding Bearing

① 70 mm stroke or less

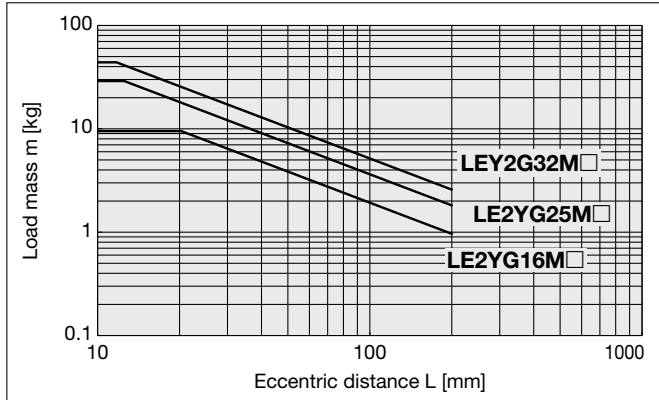

② 75 mm stroke or more

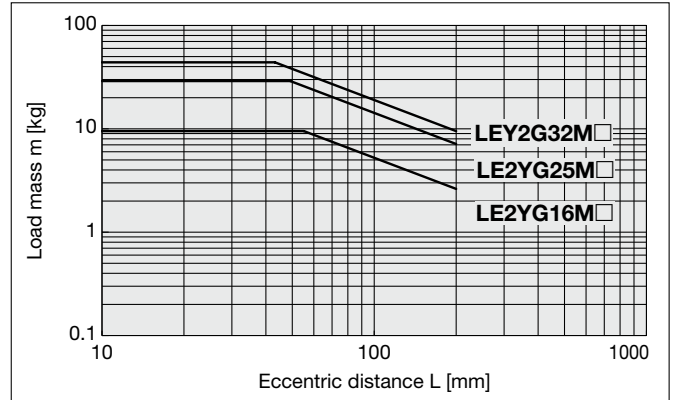

* The limit of vertical load mass varies depending on "lead" and "speed."
Check the "Speed-Work Load Graph" on pages 65 to 70.

Vertical Mounting, Ball Bushing Bearing

③ 35 mm stroke or less

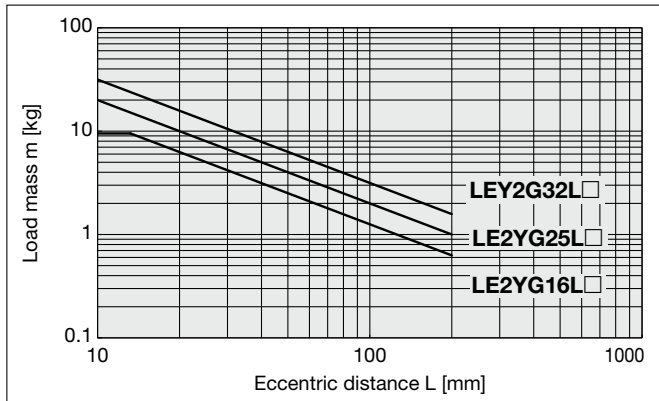

④ 40 mm stroke or more

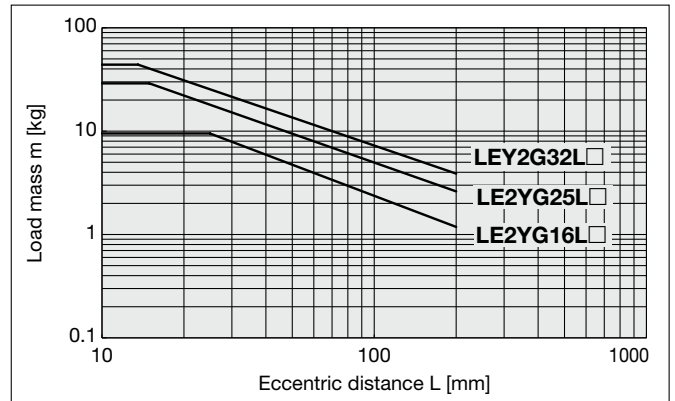

* The limit of vertical load mass varies depending on "lead" and "speed."
Check the "Speed-Work Load Graph" on pages 65 to 70.

Moment Load Graph

Horizontal Mounting, Sliding Bearing

⑤ L = 50 mm Max. speed = 200 mm/s or less

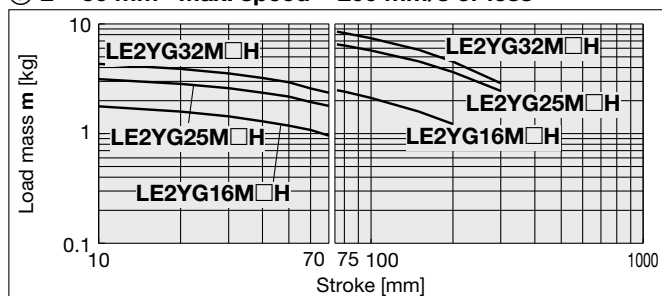

⑥ L = 100 mm Max. speed = 200 mm/s or less

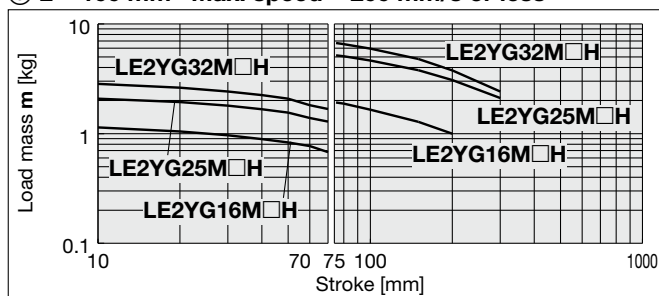

⑦ L = 50 mm Max. speed = Over 200 mm/s

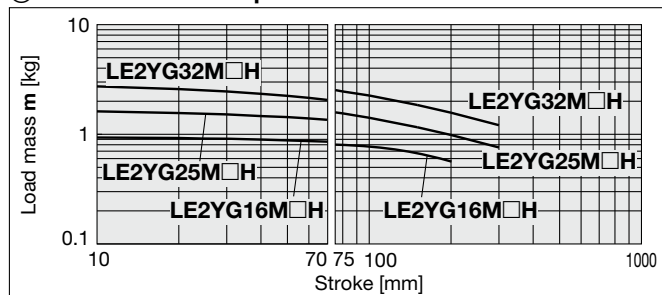

⑧ L = 100 mm Max. speed = Over 200 mm/s

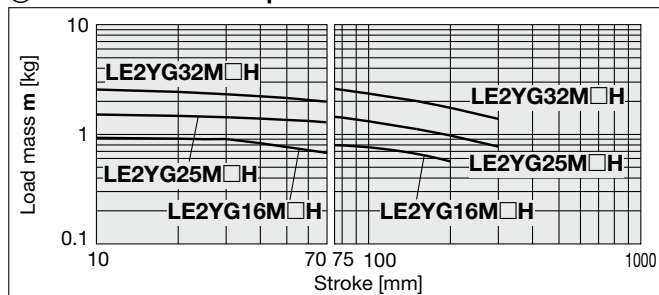

Horizontal Mounting, Ball Bushing Bearing

⑨ L = 50 mm Max. speed = 200 mm/s or less

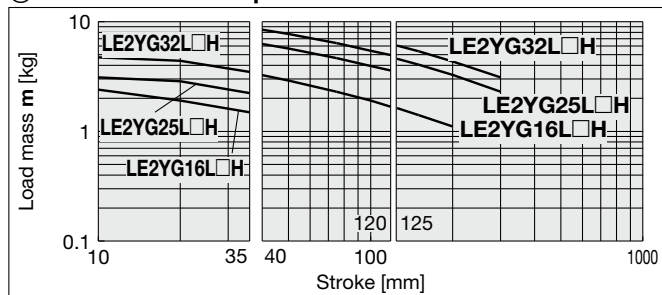

⑩ L = 100 mm Max. speed = 200 mm/s or less

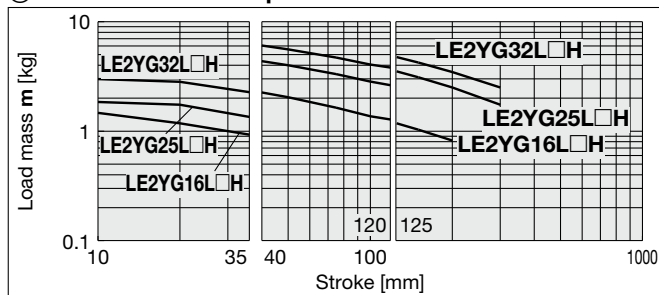

⑪ L = 50 mm Max. speed = Over 200 mm/s

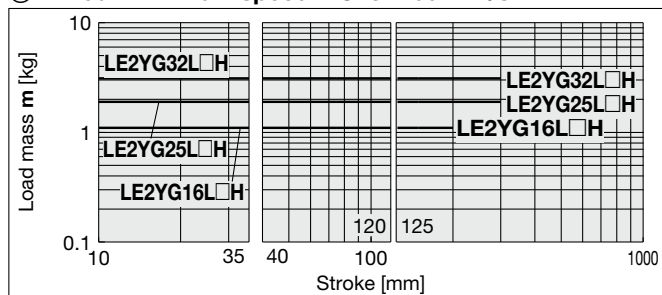

⑫ L = 100 mm Max. speed = Over 200 mm/s

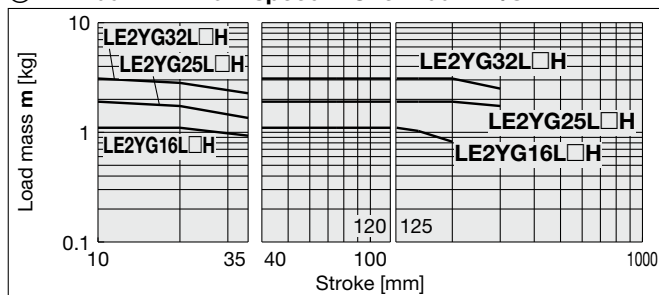

Operating Range when Used as a Stopper

LE2YG□M (Sliding bearing)

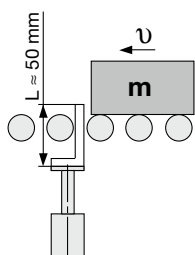

Caution

Handling Precautions

- * When used as a stopper, select a model with a stroke of 30 mm or less.
- * LE2YG□L (ball bushing bearing) cannot be used as a stopper.
- * Workpiece collision in series with guide rod cannot be permitted (Fig. a).
- * The body should not be mounted on the end. It must be mounted on the top or bottom (Fig. b).

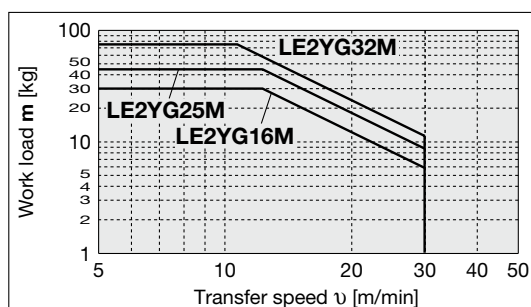
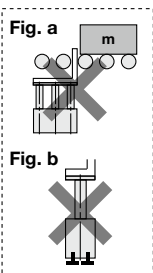

Model Selection

LE2FS□H

LE2FB□H

LE2Y□H

LE2YG□H

LE2S(H)□H

LE2R□H

Auto Switch

Speed-Work Load Graph (Guide)

* The following graphs show the values when the external guide is used together.

LE2YG16M□HA

Horizontal/Lead 10

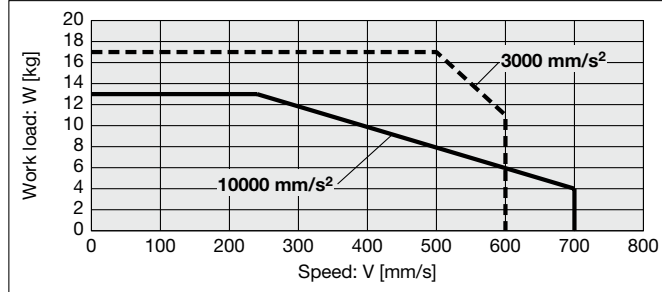

Vertical/Lead 10

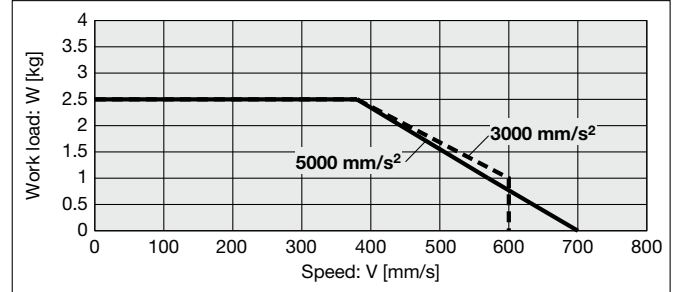

LE2YG16M□HB

Horizontal/Lead 5

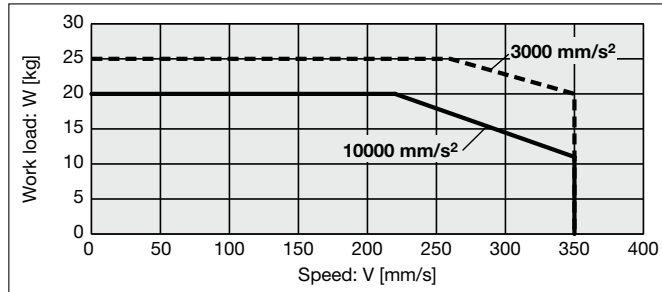

Vertical/Lead 5

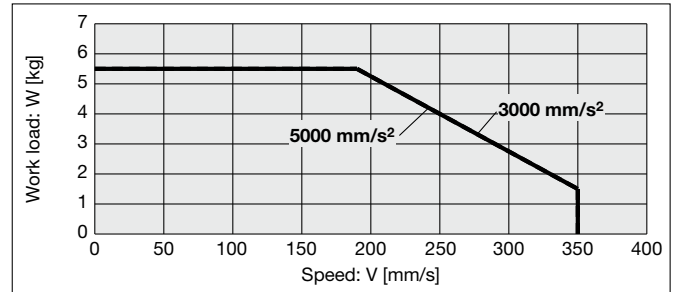

LE2YG16M□HC

Horizontal/Lead 2.5

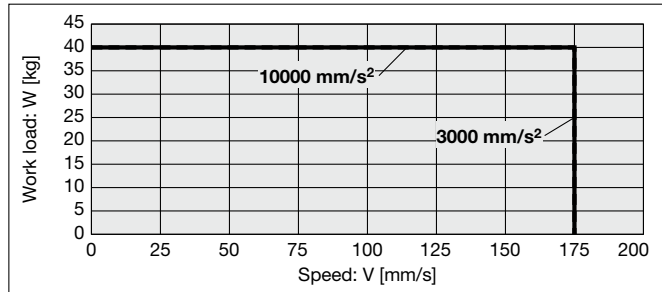

Vertical/Lead 2.5

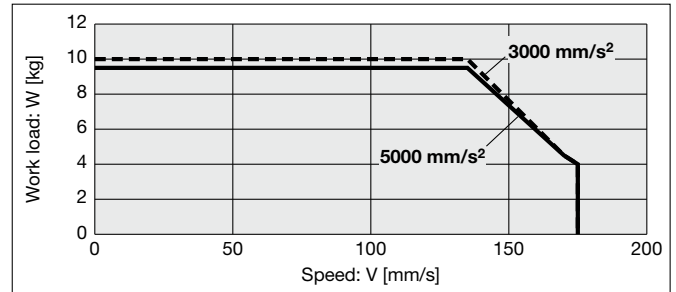

Speed-Work Load Graph (Guide)

* The following graphs show the values when the external guide is used together.

LE2YG16L□HA

Horizontal/Lead 10

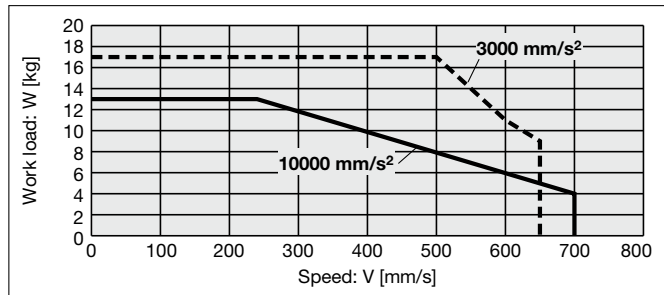

Vertical/Lead 10

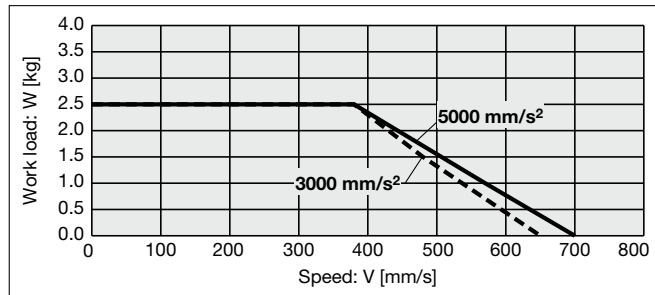

LE2YG16L□HB

Horizontal/Lead 5

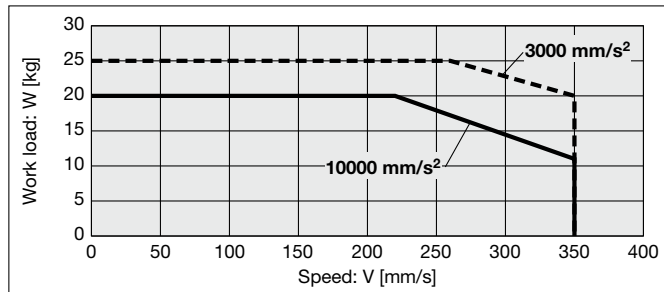

Vertical/Lead 5

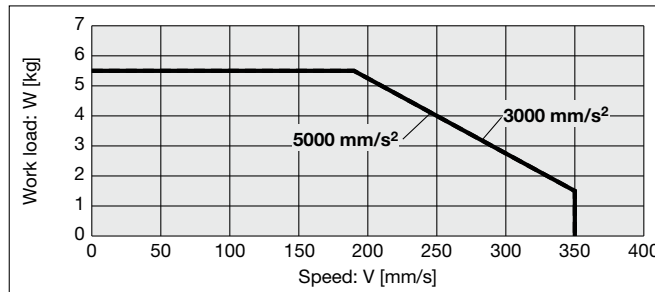

LE2YG16L□HC

Horizontal/Lead 2.5

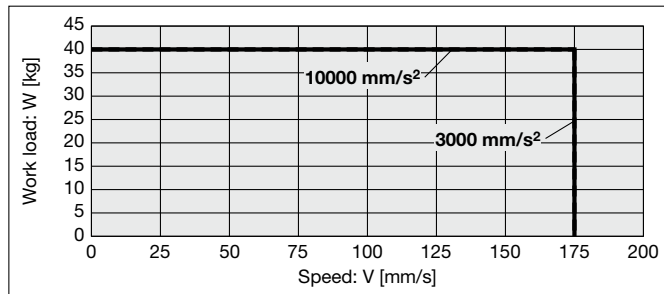

Vertical/Lead 2.5

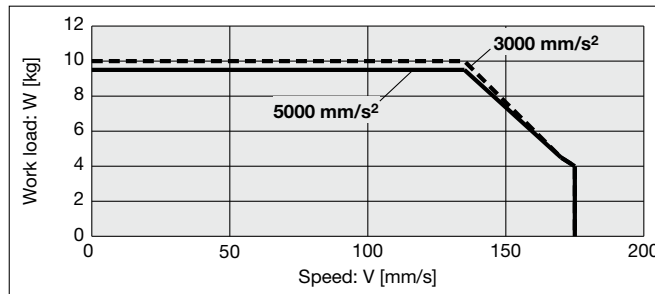

Model Selection

LE2FS□H

LE2FB□H

LE2Y□H

LE2YG□H

LE2S(H)□H

LE2R□H

Auto Switch

Speed-Work Load Graph (Guide)

* The following graphs show the values when the external guide is used together.

LE2YG25M□HH

Horizontal/Lead 20

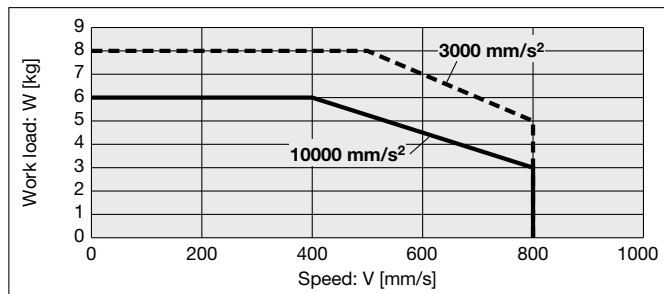

Vertical/Lead 20

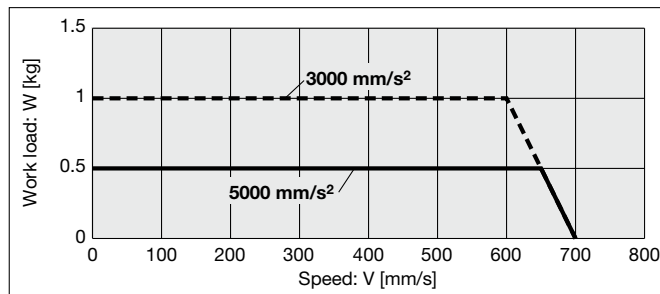

LE2YG25M□HA

Horizontal/Lead 12

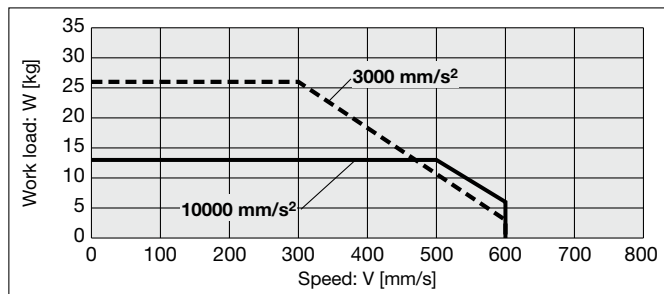

Vertical/Lead 12

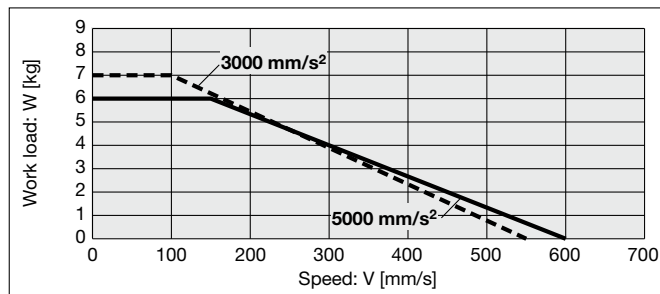

LE2YG25M□HB

Horizontal/Lead 6

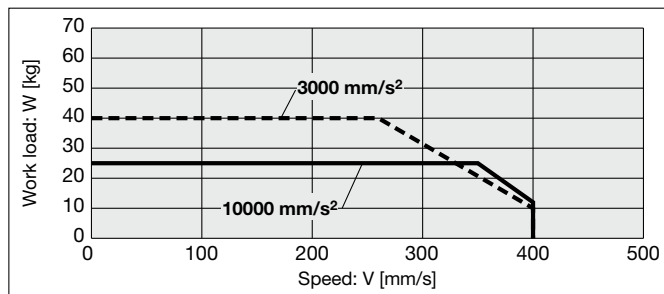

Vertical/Lead 6

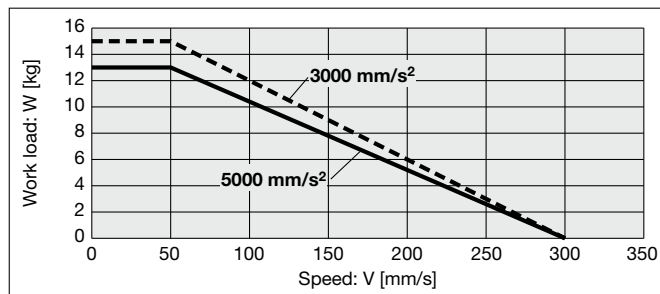

LE2YG25M□HC

Horizontal/Lead 3

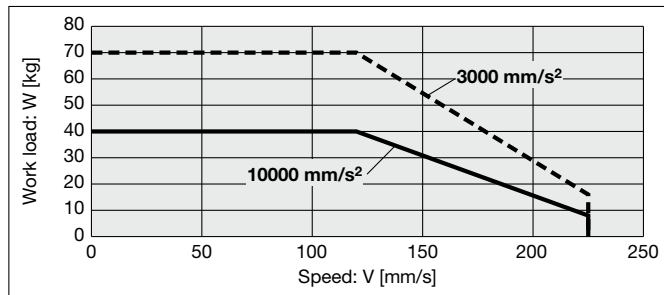

Vertical/Lead 3

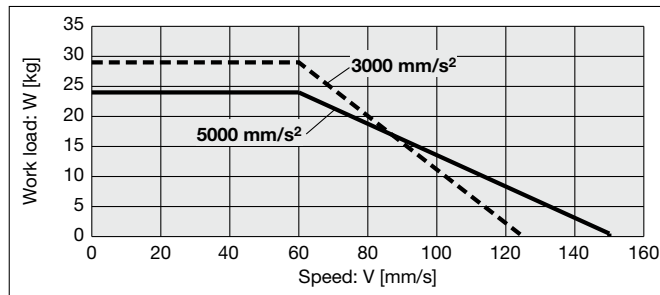

Speed-Work Load Graph (Guide)

* The following graphs show the values when the external guide is used together.

LE2YG25L□HH

Horizontal/Lead 20

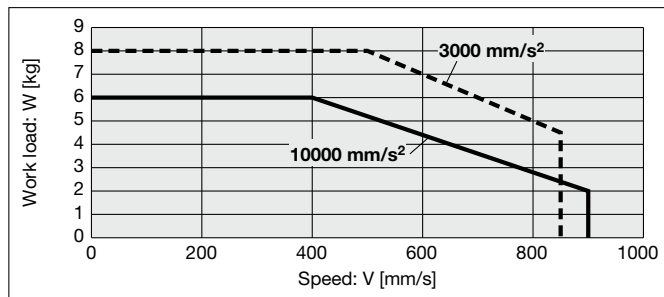

Vertical/Lead 20

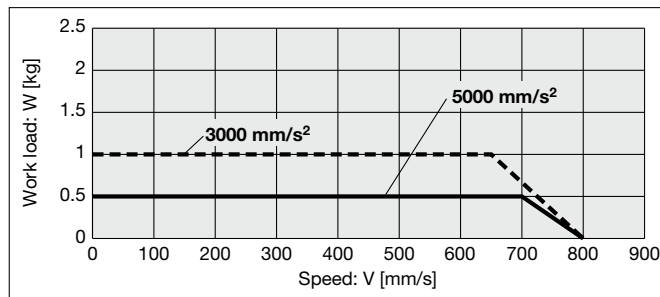

LE2YG25L□HA

Horizontal/Lead 12

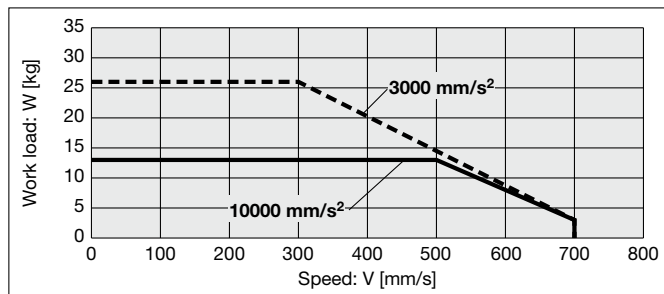

Vertical/Lead 12

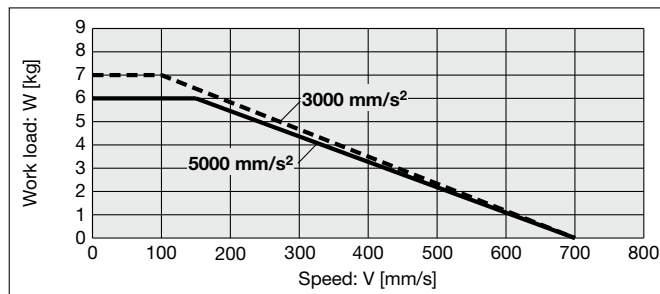

LE2YG25L□HB

Horizontal/Lead 6

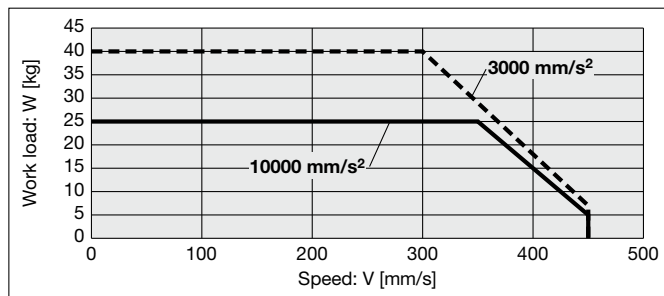

Vertical/Lead 6

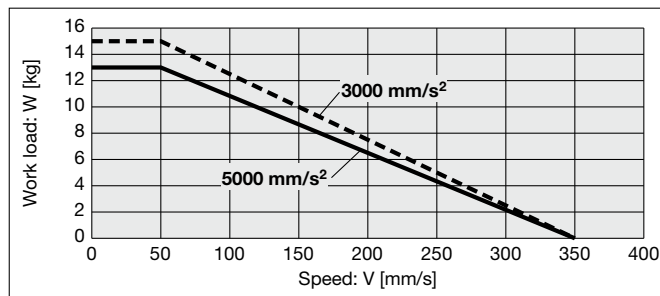

LE2YG25L□HC

Horizontal/Lead 3

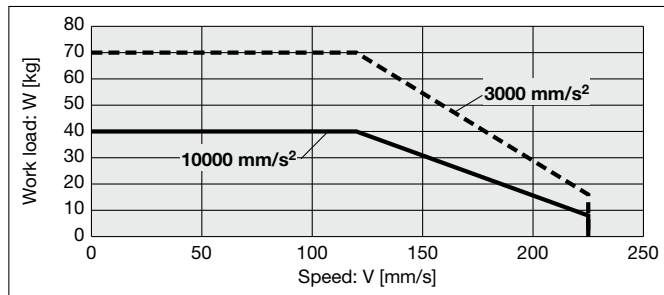

Vertical/Lead 3

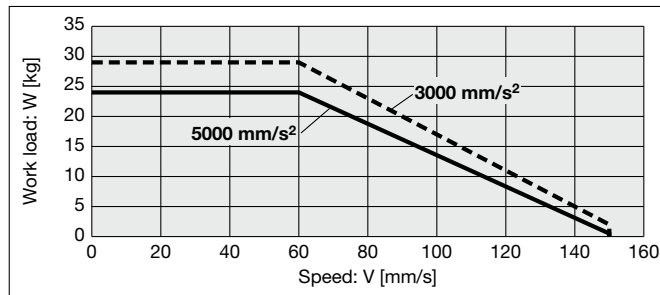

Model Selection

LE2FS□H

LE2FB□H

LE2Y□H

LE2YG□H

LE2S(H)□H

LE2R□H

Auto Switch

Speed-Work Load Graph (Guide)

* The following graphs show the values when the external guide is used together.

LE2YG32M□HH

Horizontal/Lead 24

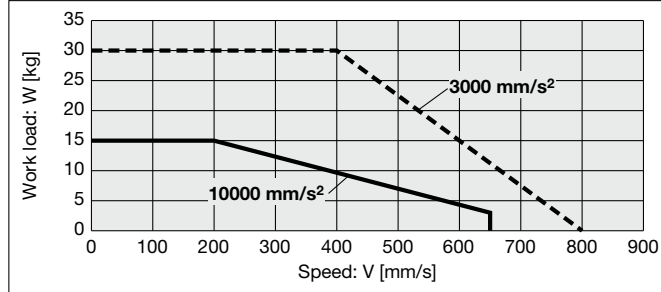

Vertical/Lead 24

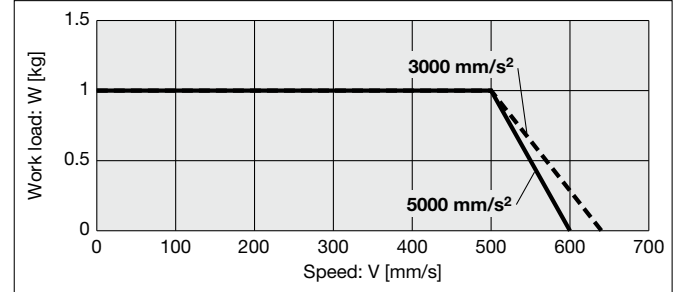

LE2YG32M□HA

Horizontal/Lead 16

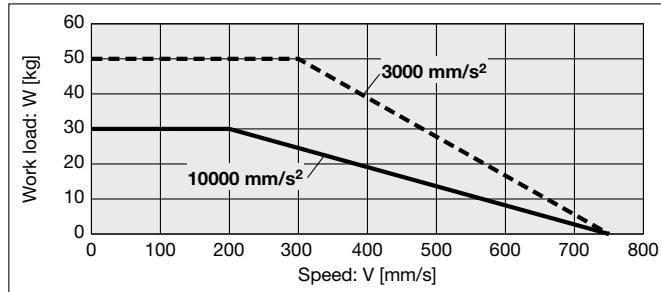

Vertical/Lead 16

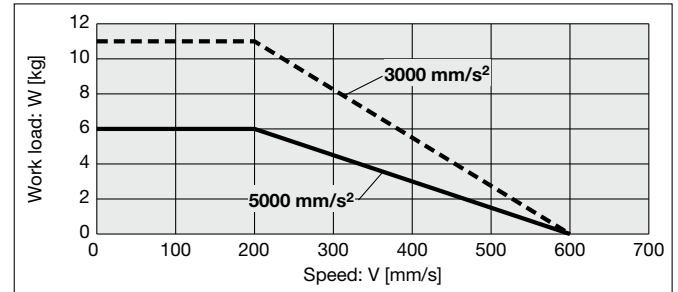

LE2YG32M□HB

Horizontal/Lead 8

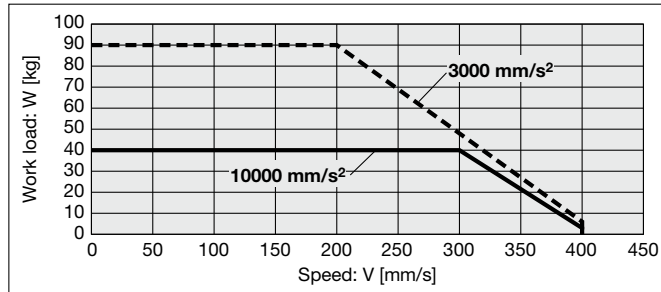

Vertical/Lead 8

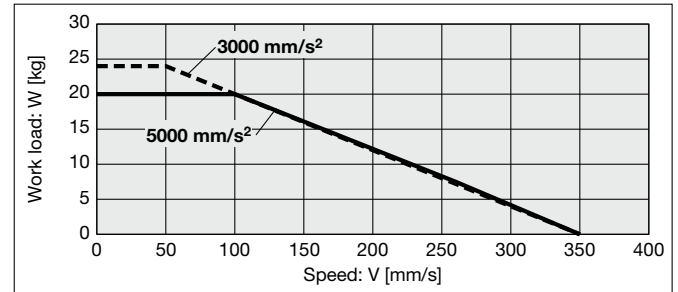

LE2YG32M□HC

Horizontal/Lead 4

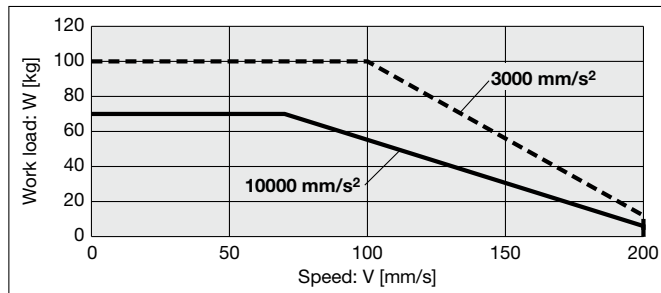

Vertical/Lead 4

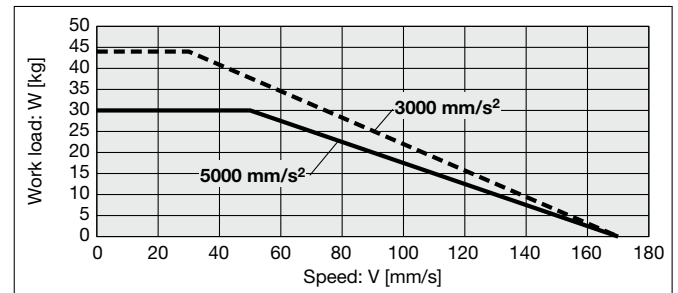

Speed-Work Load Graph (Guide)

* The following graphs show the values when the external guide is used together.

LE2YG32L□HH

Horizontal/Lead 24

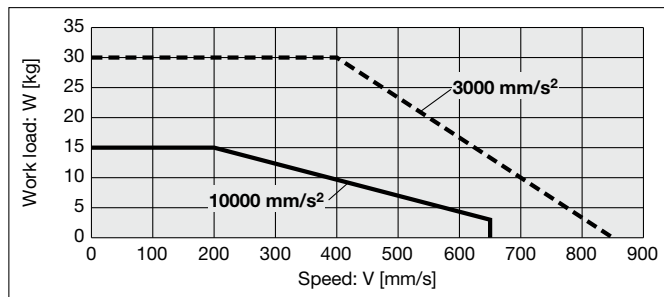

Vertical/Lead 24

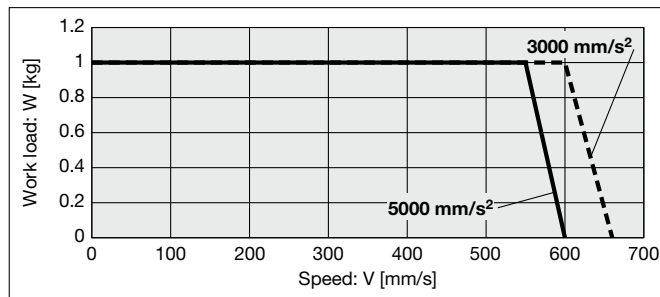

LE2YG32L□HA

Horizontal/Lead 16

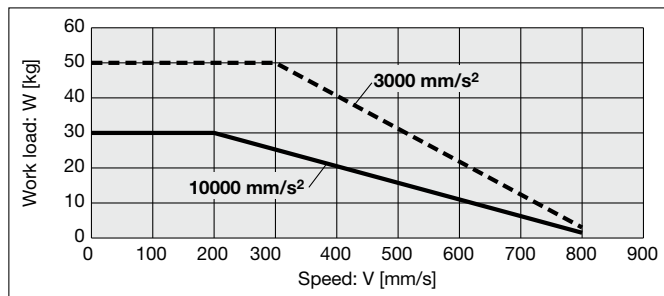

Vertical/Lead 16

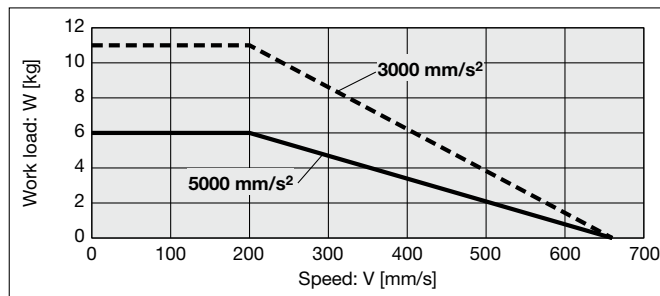

LE2YG32L□HB

Horizontal/Lead 8

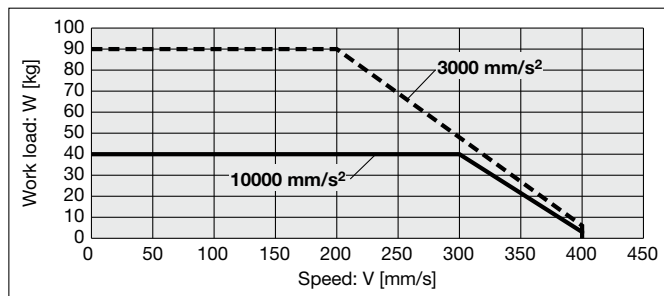

Vertical/Lead 8

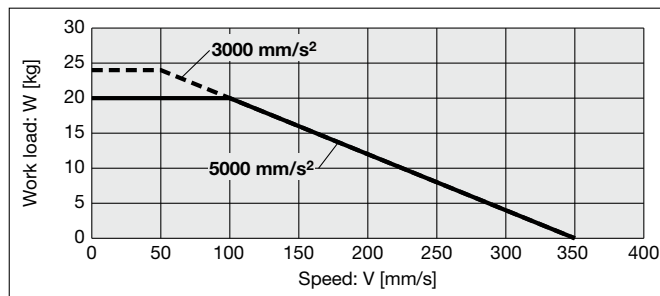

LE2YG32L□HC

Horizontal/Lead 4

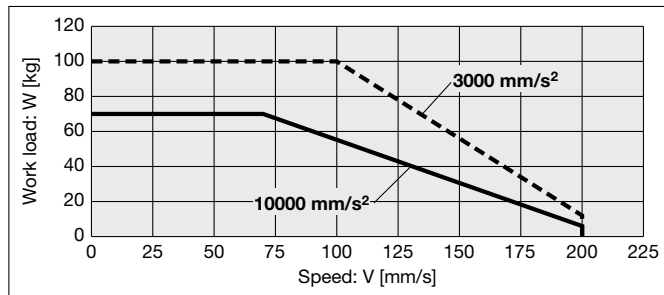

Vertical/Lead 4

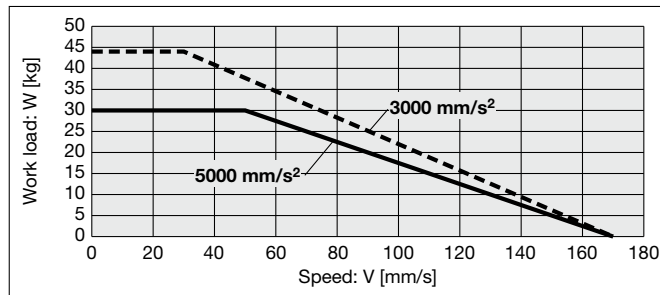

Model Selection

LE2FS□H

LE2FB□H

LE2Y□H

LE2YG□H

LE2S(H)□H

LE2R□H

Auto Switch

Allowable Rotational Torque of Plate: T

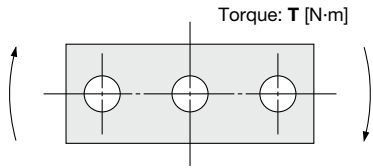

Model	Stroke [mm]					T [N·m]
	30	50	100	200	300	
LE2YG16M	0.70	0.57	1.05	0.56	—	
LE2YG16L	0.82	1.48	0.97	0.57	—	
LE2YG25M	1.56	1.29	3.50	2.18	1.36	
LE2YG25L	1.52	3.57	2.47	2.05	1.44	
LE2YG32M	2.55	2.09	5.39	3.26	1.88	
LE2YG32L	2.80	5.76	4.05	3.23	2.32	

Non-rotating Accuracy of Plate: θ

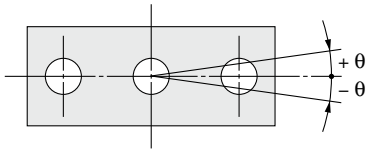

Size	Non-rotating accuracy θ	
	LEYG□M□E	LEYG□L□E
16	0.06°	0.05°
25		0.04°
32	0.05°	

Plate Displacement: δ

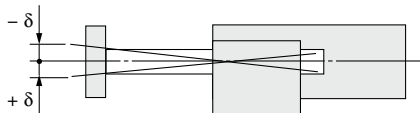

Model	Stroke [mm]					[mm]
	30	50	100	200	300	
LE2YG16M	±0.20	±0.25	±0.24	±0.27	—	
LE2YG16L	±0.13	±0.12	±0.17	±0.19	—	
LE2YG25M	±0.26	±0.31	±0.25	±0.38	±0.36	
LE2YG25L	±0.13	±0.13	±0.17	±0.20	±0.23	
LE2YG32M	±0.23	±0.29	±0.23	±0.36	±0.34	
LE2YG32L	±0.11	±0.11	±0.15	±0.19	±0.22	

* The values without a load are shown.

Force Conversion Graph (Guide)

LE2YG16□H

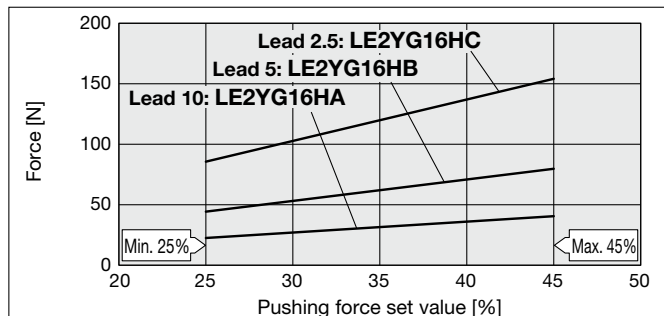

Ambient temperature	Pushing force set value [%]	Duty ratio [%]	Continuous pushing time [min]
40°C or less	45 or less	100	No restriction

LE2YG25□H

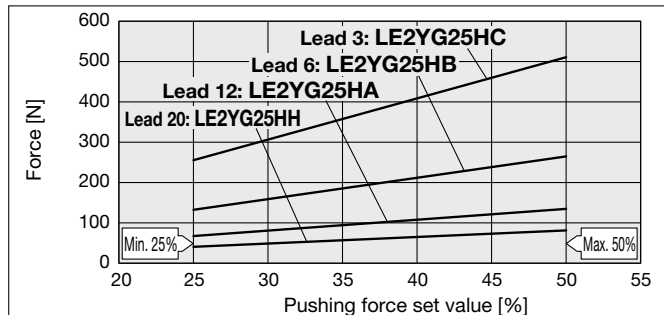

Ambient temperature	Pushing force set value [%]	Duty ratio [%]	Continuous pushing time [min]
40°C or less	50 or less	100	No restriction

LE2YG32□H

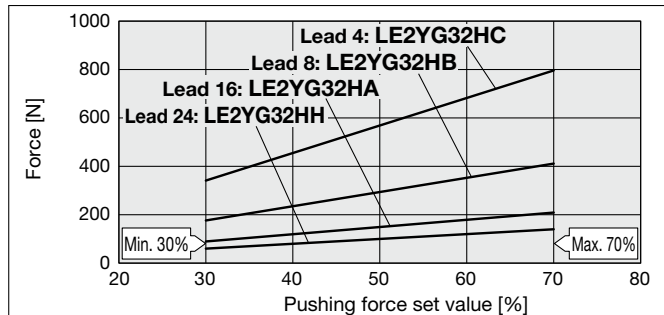

Ambient temperature	Pushing force set value [%]	Duty ratio [%]	Continuous pushing time [min]
40°C or less	70 or less	100	No restriction

<Set Values for Vertical Upward Transfer Pushing Operations>

For vertical loads (upward), set the pushing force to the max. value shown below and operate at the work load or less.

Model	LE2YG16 ^M □			LE2YG25 ^M □			LE2YG32 ^M □					
Lead	A	B	C	H	A	B	C	H	A	B	C	
Work load [kg]	0.5	1	2.5	0.5	1.5	4	9	0.5	2.5	7	16	
Pushing force	45%			50%			70%					

- Model Selection
- LE2FS□H
- LE2FB□H
- LE2Y□H
- LE2YG□H
- LE2S(H)□H
- LE2R□H
- Auto Switch

Compatible with Manifold Controller

Guide Rod Type

LE2YG□H Series LE2YG16, 25, 32

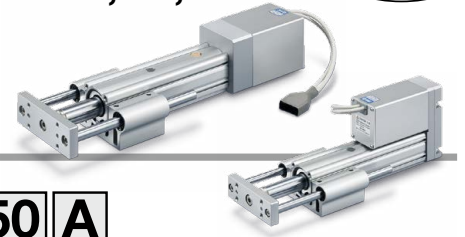

How to Order

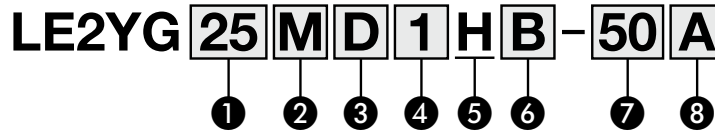

1 Size

16
25
32

2 Bearing type

M	Sliding bearing
L	Ball bushing bearing

3 Motor mounting position

T	Top side parallel
D	In-line

4 Motor cable entry direction

1	Axial
2	Right
3	Left
4	Top
5	Bottom

5 Motor type

Symbol	Type	Compatible controller
H	Battery-less absolute (Step motor 24 VDC)	JXD1

6 Lead [mm]

Symbol	LE2YG16	LE2YG25	LE2YG32
H	—	20	24
A	10	12	16
B	5	6	8
C	2.5	3	4

7 Stroke [mm]

30	30
to	to
300	300

* For details, refer to the applicable stroke table below.

8 Motor option

A	Without option
B	With lock

Applicable Stroke Table

Size	Stroke [mm]							Manufacturable stroke range
	30	50	100	150	200	250	300	
16	●	●	●	●	●	—	—	10 to 200
25	●	●	●	●	●	●	●	15 to 300
32	●	●	●	●	●	●	●	20 to 300

* Motor mounting position: For the parallel mounting type, the motor units with the following sizes and strokes protrude from the body end. Check for interference with workpieces before selecting a model.

- LE2YG16 Without lock: 30 mm stroke, With lock: 30, 50 mm strokes
- LE2YG25 Without lock: 30 mm stroke, With lock: 30, 50 mm strokes
- LE2YG32 Without lock: 30 mm stroke, With lock: 30, 50 mm strokes

* There is a limit for mounting size 25/32 top side parallel motor types and strokes of 100 mm or less.

For details on auto switches, refer to pages 61 and 131 to 133.

Use of auto switches for the guide rod type/LE2YG

- Auto switches must be inserted from the front side with the rod (plate) sticking out.
- Auto switches cannot be mounted behind the guide attachment (in the bottom groove on the side of the rod that sticks out).
- Contact SMC when mounting an auto switch in the bottom groove on the side of the rod that sticks out is required, as this is only available as a special order.

Motor Mounting Position

D: In-line

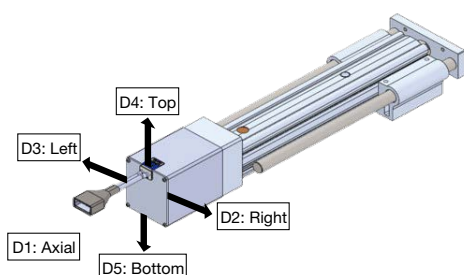

T: Top side parallel

→ T5 is not selectable.

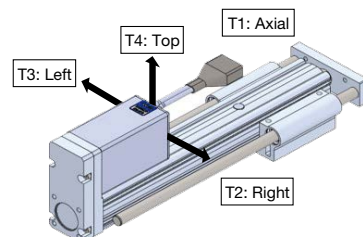

Specifications

Model		LE2YG16 ^M □H			LE2YG25 ^M □H				LE2YG32 ^M □H				
Actuator specifications	Stroke [mm]	30 to 200			30 to 300				30 to 300				
	Work load [kg]*1	Horizontal	17	25	40	8	26	40	70	30	50	90	100
		Vertical	2.5	5.5	10	1	7	15	29	1	11	24	44
	Pushing force [N]*2 *3 *4		23 to 41	44 to 80	86 to 154	41 to 81	67 to 135	132 to 265	255 to 511	60 to 140	90 to 209	176 to 411	341 to 796
	Speed [mm/s]		15 to 700	8 to 350	4 to 175	30 to 900	18 to 700	9 to 450	5 to 225	30 to 850	24 to 800	12 to 400	6 to 200
	Max. acceleration/ deceleration [mm/s ²]	Horizontal	10000										
		Vertical	5000										
	Pushing speed [mm/s]*5		1 to 50			1 to 35				1 to 30			
	Positioning repeatability [mm]		±0.02										
	Lost motion [mm]*6		0.1 or less										
	Lead [mm]		10	5	2.5	20	12	6	3	24	16	8	4
	Impact/Vibration resistance [m/s ²]*7		50/20										
	Actuation type		Ball screw + Belt (LE2YG□□TH), Ball screw (LE2YG□□DH)										
Guide type		Sliding bearing (LE2YG□M), Ball bushing bearing (LE2YG□L)											
Operating temperature range [°C]		5 to 40											
Operating humidity range [%RH]		90 or less (No condensation)											
Electric specifications	Motor size	□28			□42				□56.4				
	Motor type	Battery-less absolute (Step motor 24 VDC)											
	Encoder	Battery-less absolute encoder											
	Power supply voltage [V]	24 VDC ±10%											
Lock unit specifications	Power [W]*8 *9	Max. power 74			Max. power 71				Max. power 93				
	Type*10	Non-magnetizing lock											
	Holding force [N]	25	54	98	10	69	147	284	10	108	235	431	
	Power [W]*9	2.9			5				5				
Rated voltage [V]		24 VDC ±10%											

*1 Horizontal: Please use an external guide (friction coefficient: 0.1 or less). The work load shows the maximum value. The actual work load and transfer speed change according to the condition of the external guide.

For the speed, acceleration, and duty ratio according to the work load, check the "Speed-Work Load Graph" on pages 65 to 70.

Vertical: If the rod orientation is vertical or radial load is applied to the rod, please use an external guide (friction coefficient: 0.1 or less). The work load represents the maximum value. The actual work load and transfer speed change according to the condition of the external guide.

For the speed, acceleration, and duty ratio according to the work load, check the "Speed-Work Load Graph" on pages 65 to 70.

Set the acceleration/deceleration speed to 10000 [mm/s²] or less for the horizontal direction and 5000 [mm/s²] or less for the vertical direction.

*2 Pushing force accuracy is ±20% (F.S.).

*3 The pushing force set values for LE2YG16□H are 25% to 45%, for LE2YG25□H are 25% to 50%, and for LE2YG32□H are 30% to 70%.

The pushing force values change according to the duty ratio and pushing speed. Check the "Force Conversion Graph" on page 72.

*4 The speed and force may change depending on the cable length, load, and mounting conditions. Furthermore, if the cable length exceeds 5 m, then it will decrease by up to 10% for each 5 m. (At 15 m: Reduced by up to 20%)

*5 The allowable speed for pushing operation. When push conveying a workpiece, operate at the vertical work load or less.

*6 A reference value for correcting errors in reciprocal operation

*7 Impact resistance: No malfunction occurred when the actuator was tested with a drop tester in both an axial direction and a perpendicular direction to the lead screw. (The test was performed with the actuator in the initial state.)

Vibration resistance: No malfunction occurred in a test ranging between 45 to 2000 Hz. The test was performed in both an axial direction and a perpendicular direction to the lead screw. (The test was performed with the actuator in the initial state.)

*8 Indicates the max. power during operation (excluding the controller). This value can be used for the selection of the power supply.

*9 For an actuator with lock, add the power for the lock.

*10 With lock only

Model Selection

LE2FS□H

LE2FB□H

LE2Y□H

LE2YG□H

LE2S(H)□H

LE2R□H

Auto Switch

Weight

Top Side Parallel Motor

Series	LE2YG16M□H					LE2YG25M□H							LE2YG32M□H						
Stroke [mm]	30	50	100	150	200	30	50	100	150	200	250	300	30	50	100	150	200	250	300
Product weight [kg]	1.05	1.19	1.43	1.73	1.91	2.00	2.19	2.52	2.97	3.30	3.65	3.91	3.33	3.58	4.13	4.89	5.45	5.94	6.39
Additional weight with lock [kg]	0.19					0.33							0.64						

Series	LE2YG16L□H					LE2YG25L□H							LE2YG32L□H						
Stroke [mm]	30	50	100	150	200	30	50	100	150	200	250	300	30	50	100	150	200	250	300
Product weight [kg]	1.06	1.19	1.37	1.67	1.83	2.01	2.22	2.47	2.93	3.18	3.51	3.75	3.32	3.59	3.98	4.73	5.16	5.67	6.07
Additional weight with lock [kg]	0.19					0.33							0.64						

In-line Motor

Series	LE2YG16M□H					LE2YG25M□H							LE2YG32M□H						
Stroke [mm]	30	50	100	150	200	30	50	100	150	200	250	300	30	50	100	150	200	250	300
Product weight [kg]	1.01	1.15	1.38	1.69	1.86	1.92	2.11	2.44	2.89	3.22	3.57	3.83	3.20	3.46	4.01	4.78	5.32	5.81	6.26
Additional weight with lock [kg]	0.19					0.34							0.63						

Series	LE2YG16L□H					LE2YG25L□H							LE2YG32L□H						
Stroke [mm]	30	50	100	150	200	30	50	100	150	200	250	300	30	50	100	150	200	250	300
Product weight [kg]	1.02	1.15	1.32	1.63	1.79	1.93	2.14	2.39	2.85	3.10	3.43	3.67	3.20	3.47	3.86	4.61	5.03	5.54	5.94
Additional weight with lock [kg]	0.19					0.34							0.63						

Dimensions: Top Side Parallel Motor

LE2YG16TH

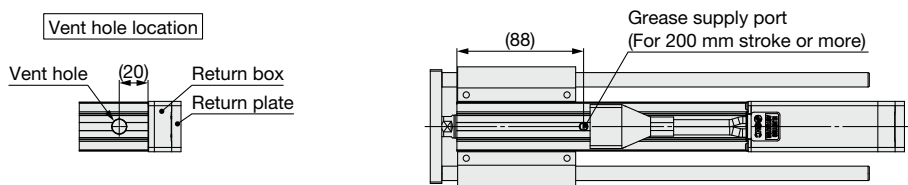

<Rod operating range>
 *1 The range of movement of the rod according to the movement instructions.
 Make sure that workpieces mounted on the rod do not interfere with other workpieces or the facilities around the rod.
 *2 Indicates the factory default origin position (0 mm)
 *3 [] refers to when the rotation direction reference is changed.

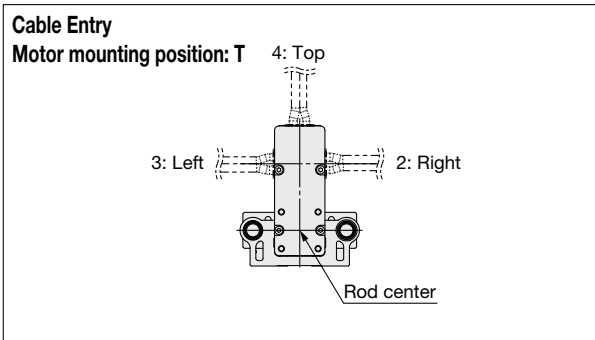
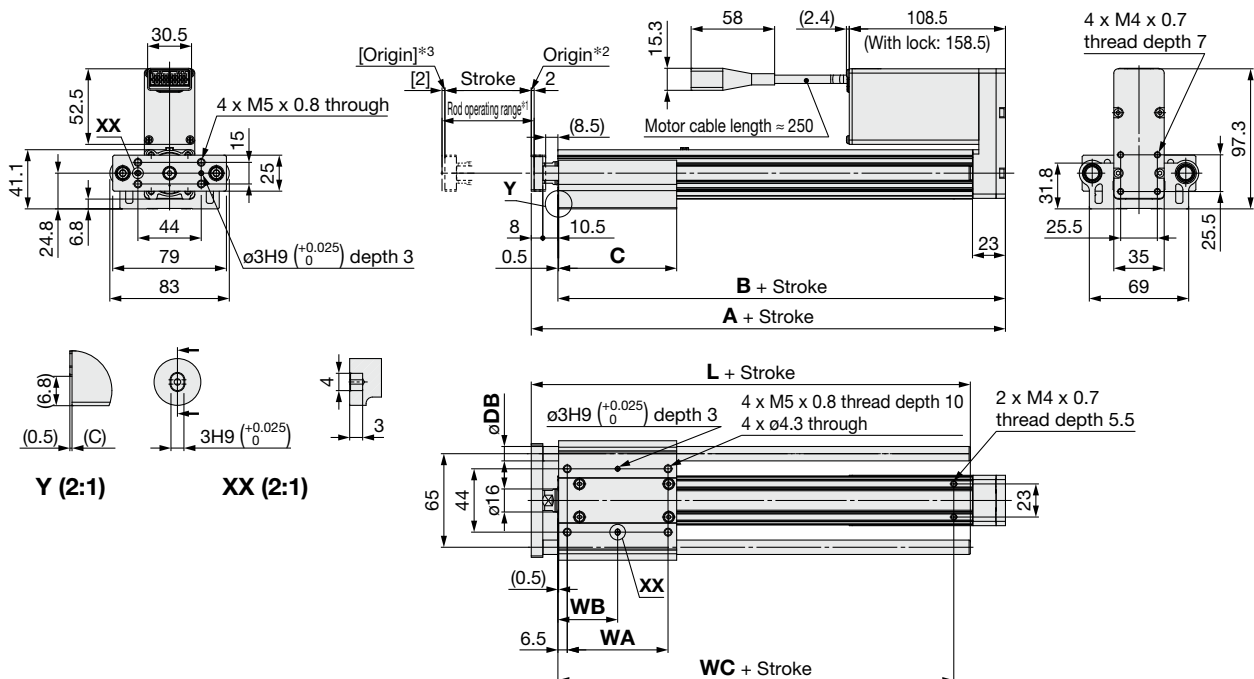

Dimensions LE2YG16T

Stroke [mm]	A	B	C	WA	WB	WC
30	109.5	91	37	25	19	55
50, 100			52	40	26.5	
150, 200	129.5	111	82	70	41.5	75

LE2YG16M (Sliding bearing)

Stroke [mm]	L	DB
30, 50	51.5	10
100	74.5	
150, 200	105	

LE2YG16L (Ball bushing bearing)

Stroke [mm]	L	DB
30, 50, 100	75	8
150, 200	105	

* When the stroke exceeds 100 mm and the mounting orientation is horizontal, the body will be bent. Mounting the support block is recommended. (Please order it separately.)
 Order no.: LEYG-S016 (Accessory: 2 body mounting screws)
 * When "With lock" is selected, the motor body will stick out from the end of the body for strokes of 50 mm or less.
 Check for interference with workpieces before selecting a model.
 * For details, refer to the catalog.
 * The axial cable entry direction is shown.

Model Selection
 LE2FS□H
 LE2FB□H
 LE2Y□H
 LE2YG□H
 LE2S(H)□H
 LE2R□H
 Auto Switch

Dimensions: Top Side Parallel Motor

LE2YG25TH

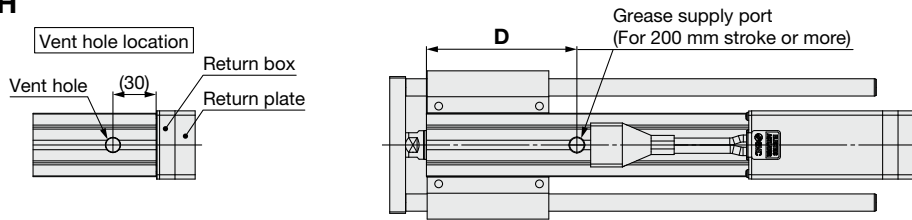

<Rod operating range>

- *1 The range of movement of the rod according to the movement instructions.
Make sure that workpieces mounted on the rod do not interfere with other workpieces or the facilities around the rod.
- *2 Indicates the factory default origin position (0 mm)
- *3 [] refers to when the rotation direction reference is changed.

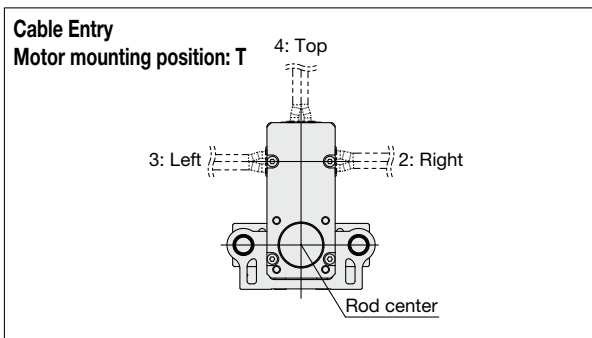
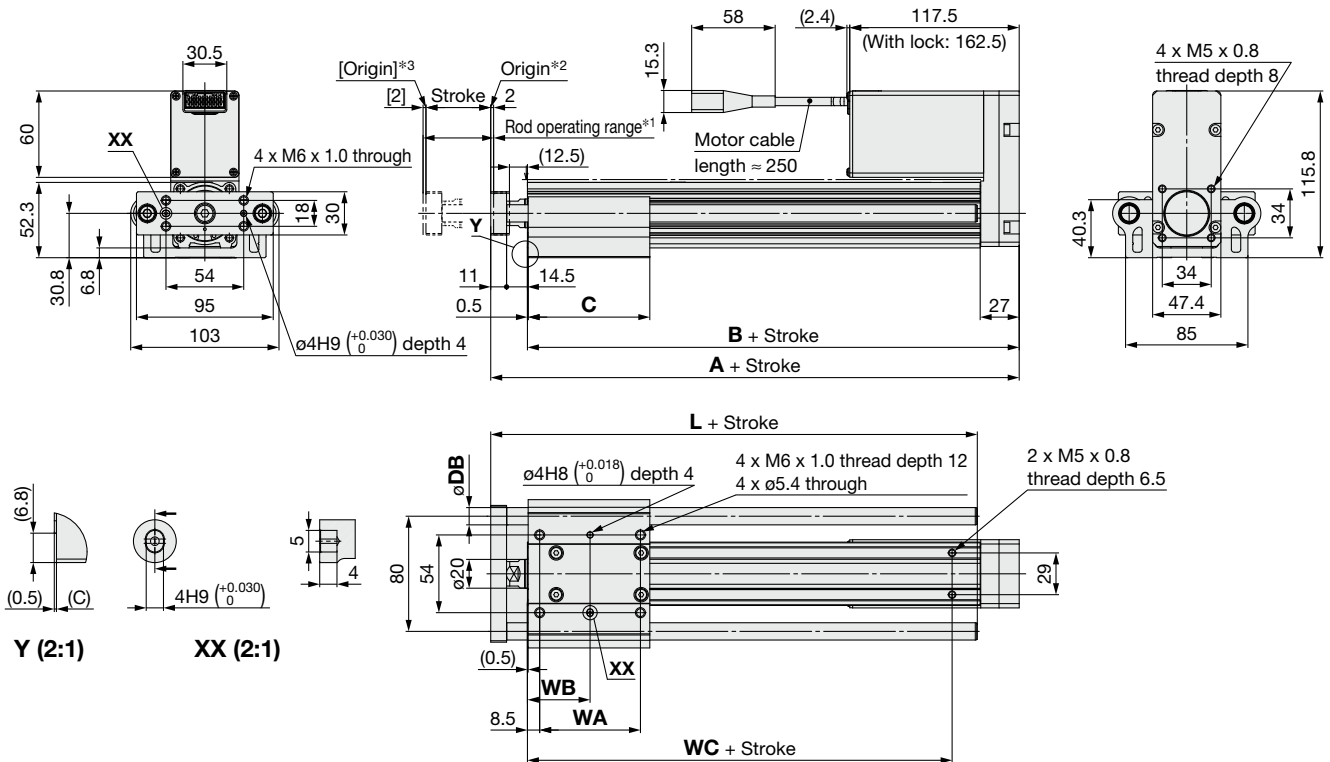

Dimensions

LE2YG25T

Stroke [mm]	A	B	C	D	WA	WB	WC
30	142	116.5	50	74.5	35	26	70
50, 100			67.5	79.5	50	33.5	
150, 200	167	141.5	84.5	104.5	70	43.5	95
250, 300			102		85	51	

LE2YG25M (Sliding bearing)

Stroke [mm]	L	DB
30, 50	67.5	12
100, 150	100.5	
200, 250, 300	138	

LE2YG25L (Ball bushing bearing)

Stroke [mm]	L	DB
30, 50, 100	91	10
150	115	
200, 250, 300	133	

* When the stroke exceeds 100 mm and the mounting orientation is horizontal, the body will be bent. Mounting the support block is recommended. (Please order it separately.)
Order no.: LEYG-S025 (Accessory: 2 body mounting screws)

* For details, refer to the catalog.

* The axial cable entry direction is shown.

Dimensions: Top Side Parallel Motor

LE2YG32TH

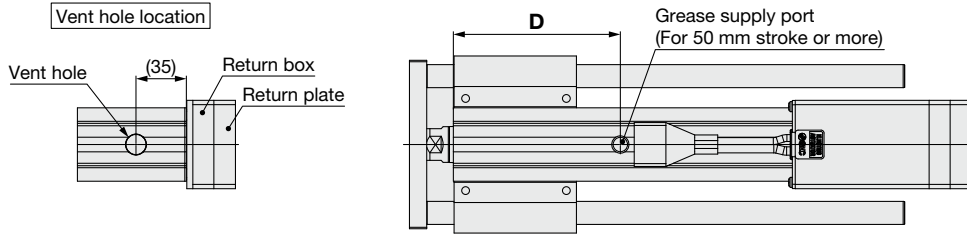

<Rod operating range>
 *1 The range of movement of the rod according to the movement instructions.
 Make sure that workpieces mounted on the rod do not interfere with other workpieces or the facilities around the rod.
 *2 Indicates the factory default origin position (0 mm)
 *3 [] refers to when the rotation direction reference is changed.

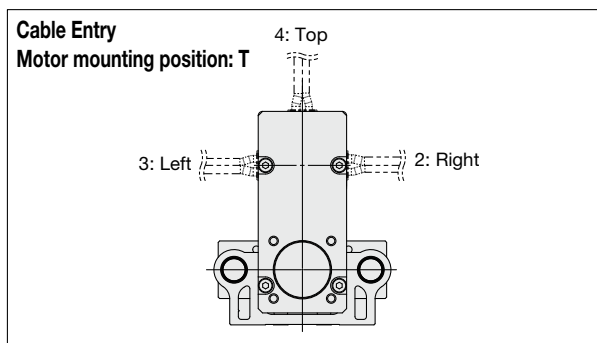
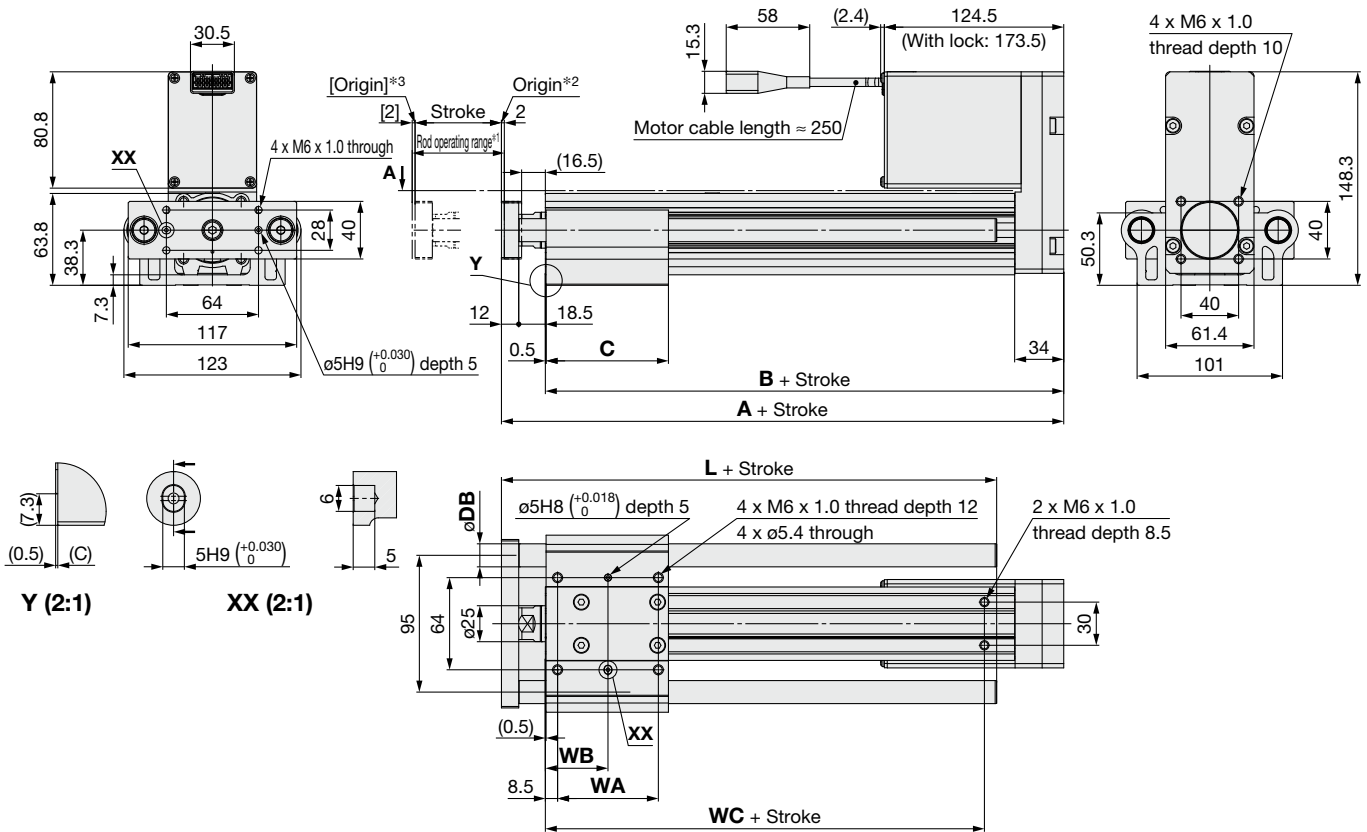

Dimensions

LE2YG32T

Stroke [mm]	A	B	C	D	WA	WB	WC
30	161	130	55	—	40	28.5	75
50, 100			68	86	50	33.5	
150, 200	191	160	85	116	70	43.5	105
250, 300			102		85	51	

LE2YG32M (Sliding bearing)

Stroke [mm]	L	DB
30, 50	74	16
100, 150	107	
200, 250, 300	144	

LE2YG32L (Ball bushing bearing)

Stroke [mm]	L	DB
30, 50, 100	97.5	13
150	116.5	
200, 250, 300	134	

* When the stroke exceeds 100 mm and the mounting orientation is horizontal, the body will be bent. Mounting the support block is recommended. (Please order it separately.)
 Order no.: LEYG-S032 (Accessory: 2 body mounting screws)
 * For details, refer to the catalog.
 * The axial cable entry direction is shown.

Dimensions: In-line Motor

LE2YG16DH

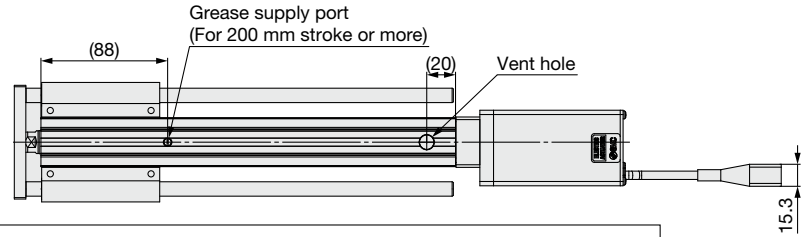

<Rod operating range>
 *1 The range of movement of the rod according to the movement instructions.
 Make sure that workpieces mounted on the rod do not interfere with other workpieces or the facilities around the rod.
 *2 Indicates the factory default origin position (0 mm)
 *3 [] refers to when the rotation direction reference is changed.

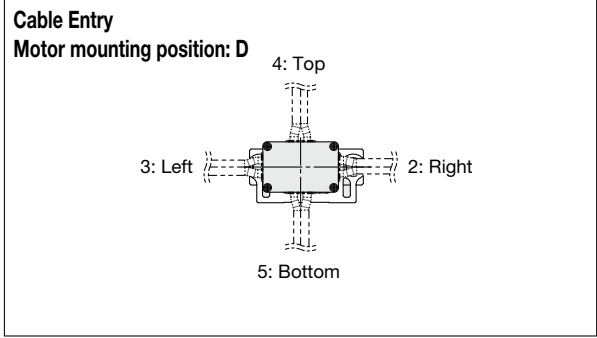
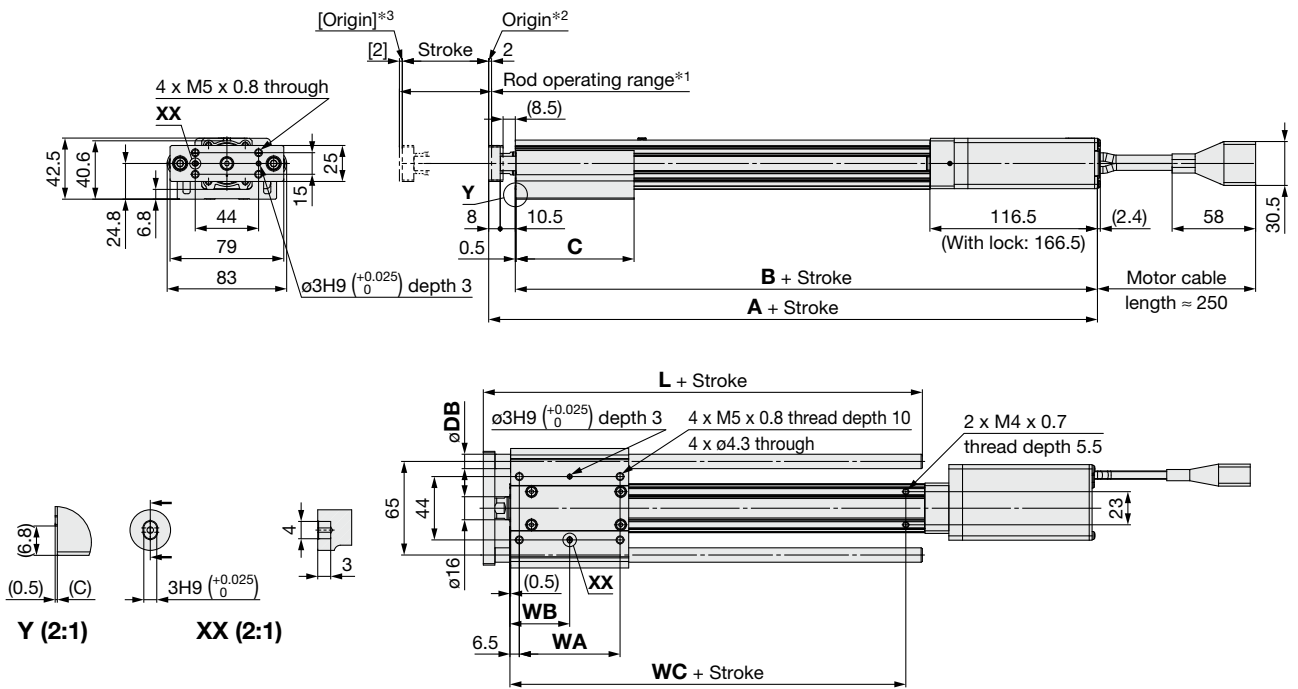

Dimensions

Stroke [mm]	A		B		C	WA	WB	WC
	Without lock	With lock	Without lock	With lock				
30	203	253	184.5	234.5	37	25	19	55
50, 100	203	253	184.5	234.5	52	40	26.5	55
150, 200	223	273	204.5	254.5	82	70	41.5	75

LE2YG16M (Sliding bearing)

Stroke [mm]	L	DB
30, 50	51.5	10
100	74.5	
150, 200	105	

LE2YG16L (Ball bushing bearing)

Stroke [mm]	L	DB
30, 50, 100	75	8
150, 200	105	

* When the stroke exceeds 100 mm and the mounting orientation is horizontal, the body will be bent. Mounting the support block is recommended. (Please order it separately.)
 Order no.: LEYG-S016 (Accessory: 2 body mounting screws)
 * For details, refer to the catalog.
 * The axial cable entry direction is shown.

Dimensions: In-line Motor

LE2YG25DH

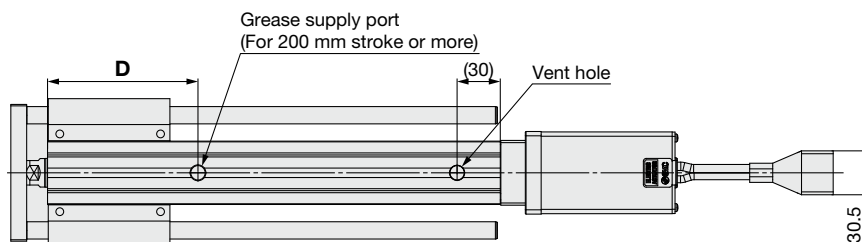

<Rod operating range>
 *1 The range of movement of the rod according to the movement instructions.
 Make sure that workpieces mounted on the rod do not interfere with other workpieces or the facilities around the rod.
 *2 Indicates the factory default origin position (0 mm)
 *3 [] refers to when the rotation direction reference is changed.

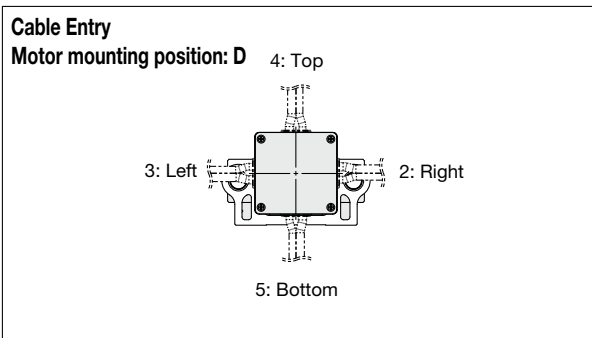
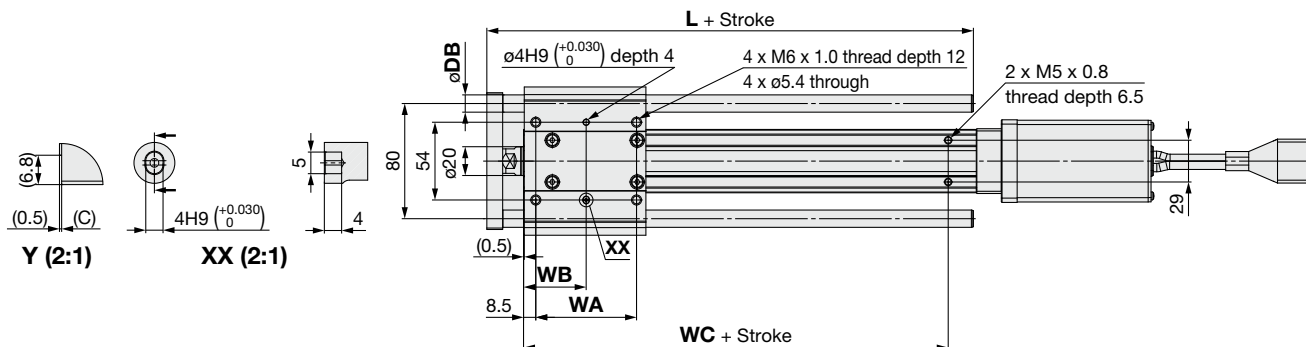
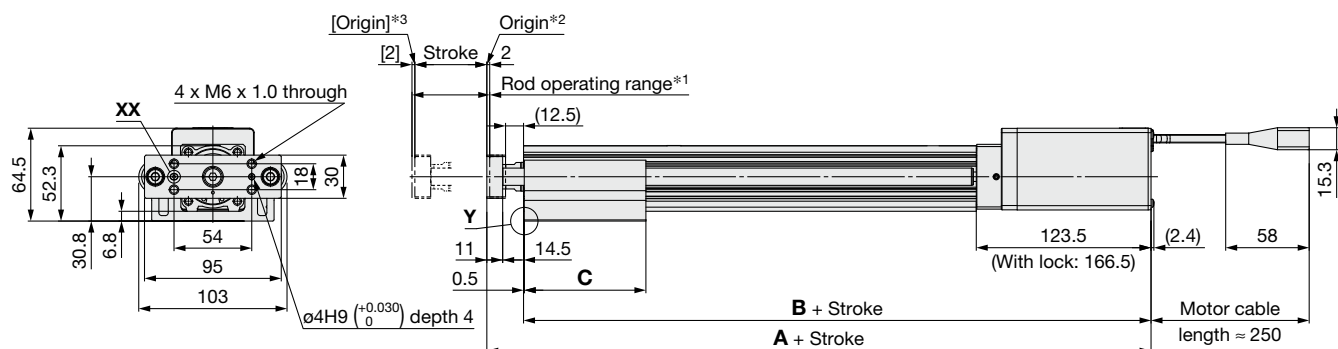

Dimensions

LE2YG25D

Stroke [mm]	A		B		C	D	WA	WB	WC
	Without lock	With lock	Without lock	With lock					
30					50	74.5	35	26	
50, 100	237	282	211	256	67.5	79.5	50	33.5	70
150, 200	262	307	236	281	84.5	104.5	70	43.5	95
250, 300					102				

LE2YG25M (Sliding bearing)

Stroke [mm]	L	DB
30, 50	67.5	12
100, 150	100.5	
200, 250, 300	138	

LE2YG25L (Ball bushing bearing)

Stroke [mm]	L	DB
30, 50, 100	91	10
150	115	
200, 250, 300	133	

* When the stroke exceeds 100 mm and the mounting orientation is horizontal, the body will be bent. Mounting the support block is recommended. (Please order it separately.)
 Order no.: LEYG-S025 (Accessory: 2 body mounting screws)
 * For details, refer to the catalog.
 * The axial cable entry direction is shown.

Model Selection

LE2FS□H

LE2FB□H

LE2Y□H

LE2YG□H

LE2S(H)□H

LE2R□H

Auto Switch

Dimensions: In-line Motor

LE2YG32DH

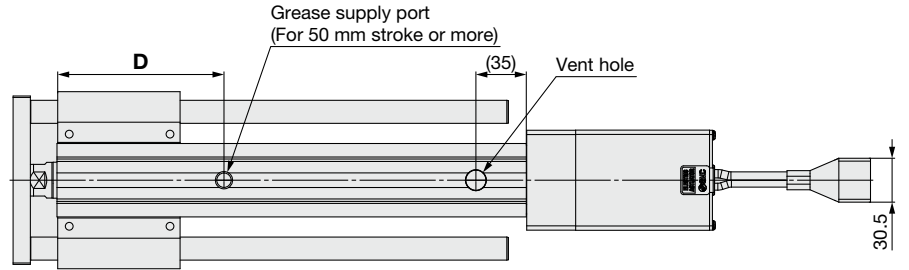

<Rod operating range>
 *1 The range of movement of the rod according to the movement instructions.
 Make sure that workpieces mounted on the rod do not interfere with other workpieces or the facilities around the rod.
 *2 Indicates the factory default origin position (0 mm)
 *3 [] refers to when the rotation direction reference is changed.

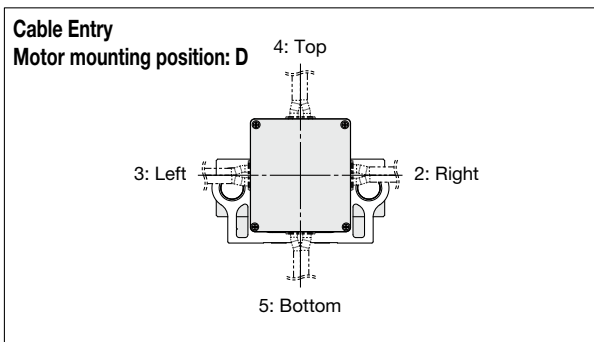
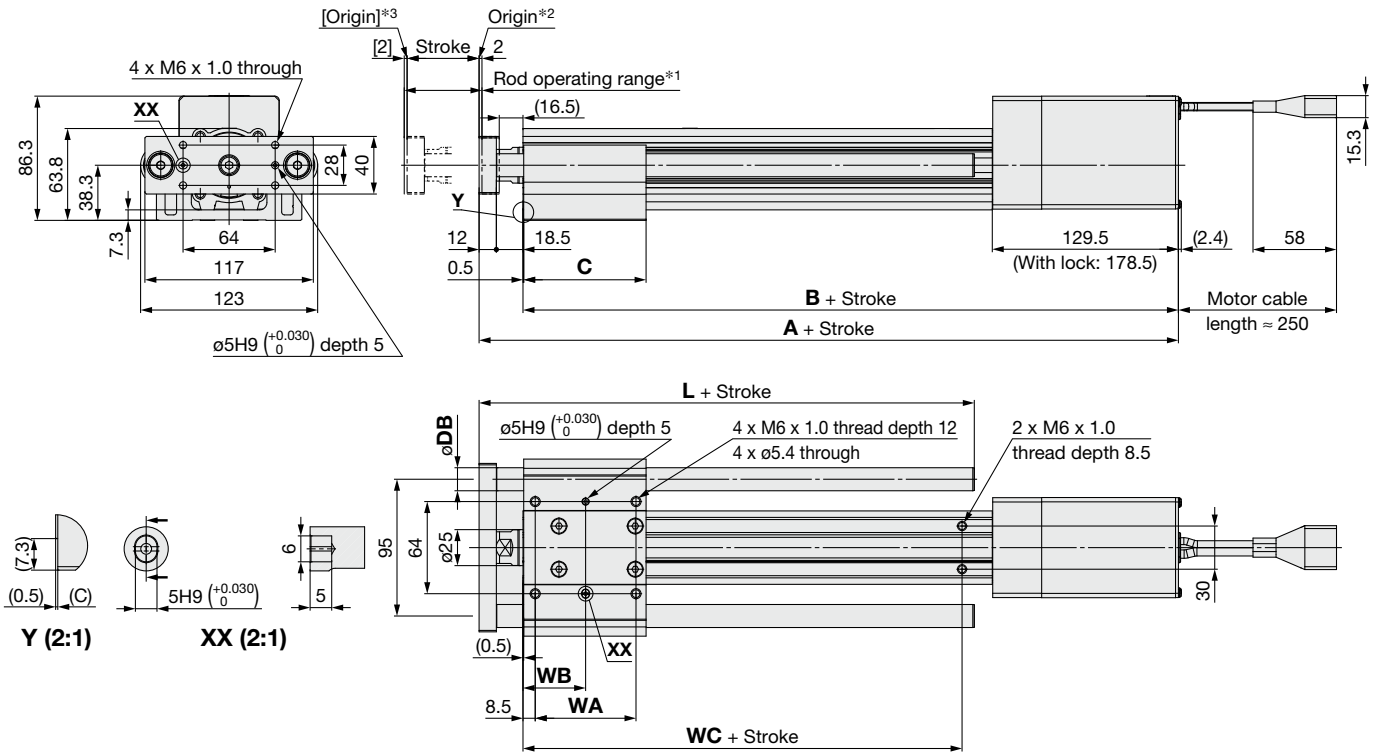

Dimensions

LE2YG32D

Stroke [mm]	A		B		C	D	WA	WB	WC
	Without lock	With lock	Without lock	With lock					
30	256.5	305.5	225.5	274.5	55	—	40	28.5	75
50, 100					68	86	50	33.5	
150, 200	286.5	335.5	255.5	304.5	85	116	70	43.5	105
250, 300					102		85	51	

LE2YG32M (Sliding bearing)

Stroke [mm]	L	DB
30, 50	74	16
100, 150	107	
200, 250, 300	144	

LE2YG32L (Ball bushing bearing)

Stroke [mm]	L	DB
30, 50, 100	97.5	13
150	116.5	
200, 250, 300	134	

* When the stroke exceeds 100 mm and the mounting orientation is horizontal, the body will be bent. Mounting the support block is recommended. (Please order it separately.)
 Order no.: LEYG-S032 (Accessory: 2 body mounting screws)

* For details, refer to the catalog.

* The axial cable entry direction is shown.

Support Block

●Guide for support block application

When the stroke exceeds 100 mm and the mounting orientation is horizontal, the body will be bent. Mounting the support block is recommended. (Please order it separately from the models shown below.)

Support Block Model

LEYG-S□016

●Size

016	For size 16
025	For size 25
032	For size 32

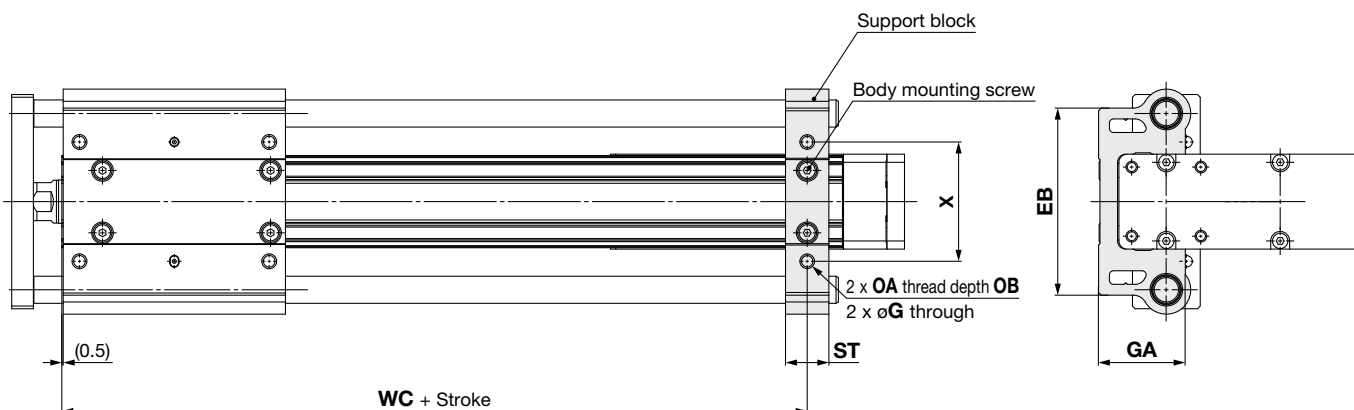
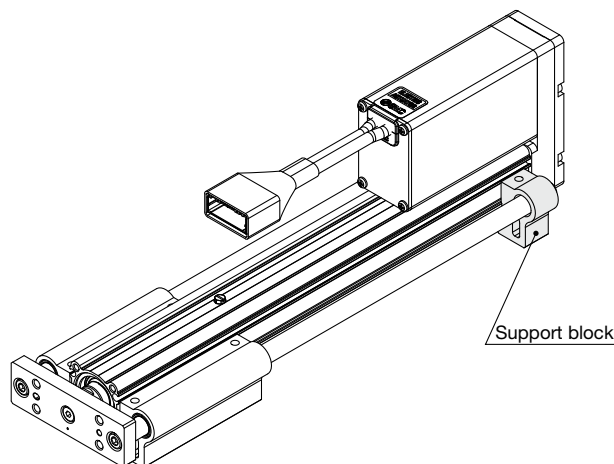

⚠ Caution

Do not install the body using only a support block.
The support block should be used only for support.

Size	Model	Stroke range	EB	G	GA	OA	OB	ST	WC	X
16	LEYG-S016	Up to 100	69	4.3	31.8	M5 x 0.8	10	16	55	44
		105 to 200							75	
25	LEYG-S025	Up to 100	85	5.4	40.3	M6 x 1.0	12	20	70	54
		105 to 300							95	
32	LEYG-S032	Up to 100	101	(5.4)	(50.3)	M6 x 1.0	12	22	75	64
		105 to 300							105	

* Two body mounting screws are included with the support block.

* The through holes of the LEYG-S025 and LEYG-S032 cannot be used for the top side parallel motor type. Use taps on the bottom.

Model Selection

LE2FS□H

LE2FB□H

LE2Y□H

LE2YG□H

LE2S(H)□H

LE2R□H

Auto Switch

Slide Tables

Compact Type *LE2S□H Series*

p. 85

Battery-less Absolute (Step Motor 24 VDC)

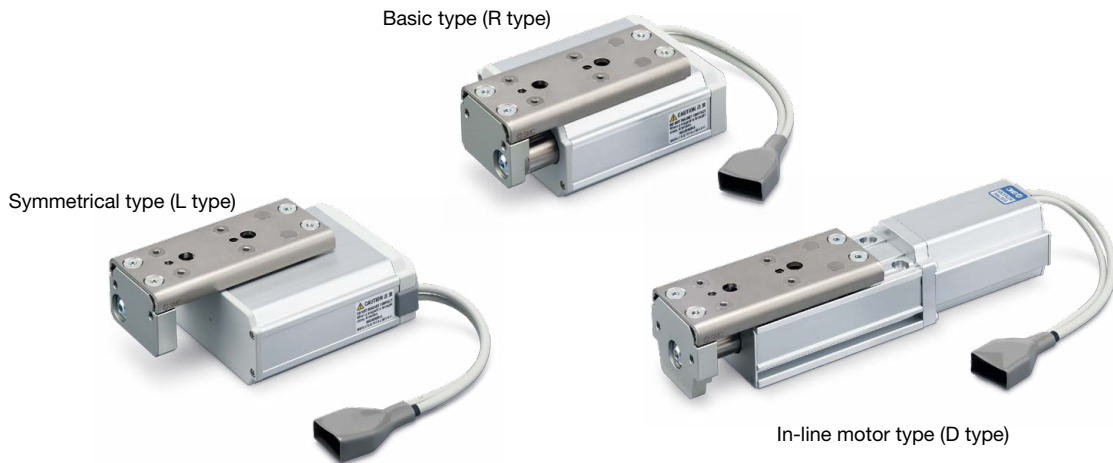

High Rigidity Type *LE2SH□H Series*

p. 103

Battery-less Absolute (Step Motor 24 VDC)

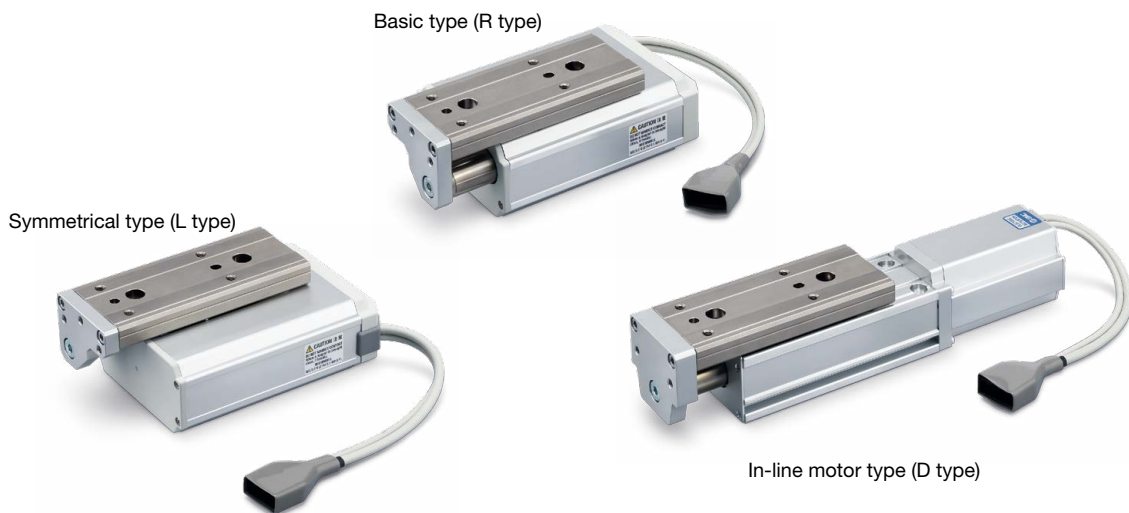

Model Selection

LE2FS□H

LE2FB□H

LE2Y□H

LE2YG□H

LE2S(H)□H

LE2R□H

Auto Switch

Model Selection 1



LE2S□H Series ▶ p. 94

Selection Procedure For the high rigidity type LE2SH□H series, refer to page 103.



Selection Example

Step 1 Check the work load-speed. <Speed-Work load graph> (page 86)

Select a model based on the workpiece mass and speed while referencing the speed-work load graph. Selection example) The LE2S16□HJ-50 can be temporarily selected as a possible candidate based on the graph shown on the right side.

Operating conditions

- Workpiece mass: 1 [kg]
- Workpiece mounting condition:
- Speed: 220 [mm/s]
- Mounting orientation: Vertical
- Stroke: 50 [mm]
- Acceleration/Deceleration: 5000 [mm/s²]
- Cycle time: 0.5 s

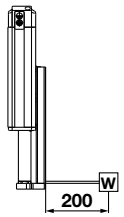

Step 2 Check the cycle time.

It is possible to find an approximate cycle time by using method 1, but if a more detailed cycle time is required, use method 2.

Method 1: Check the cycle time graph. (page 87)

Method 2: Calculation <Speed-Work load graph> (page 86)

Calculate the cycle time using the following calculation method. Calculation example) T1 to T4 can be calculated as follows.

Cycle time:

T can be found from the following equation.

$$T = T1 + T2 + T3 + T4 \text{ [s]}$$

- T1: Acceleration time and T3: Deceleration time can be found by the following equation.

$$T1 = V/a1 \text{ [s]}$$

$$T3 = V/a2 \text{ [s]}$$

- T2: Constant speed time can be found from the following equation.

$$T2 = \frac{L - 0.5 \cdot V \cdot (T1 + T3)}{V} \text{ [s]}$$

- T4: Settling time varies depending on the conditions such as motor types, load, and in position of the step data. Therefore, calculate the settling time while referencing the following value.

$$T4 = 0.15 \text{ [s]}$$

$$T1 = V/a1 = 220/5000 = 0.04 \text{ [s]}$$

$$T3 = V/a2 = 220/5000 = 0.04 \text{ [s]}$$

$$T2 = \frac{L - 0.5 \cdot V \cdot (T1 + T3)}{V} = \frac{50 - 0.5 \cdot 220 \cdot (0.04 + 0.04)}{220}$$

$$= 0.19 \text{ [s]}$$

$$T4 = 0.15 \text{ [s]}$$

The cycle time can be found as follows.

$$T = T1 + T2 + T3 + T4 = 0.04 + 0.19 + 0.04 + 0.15 = 0.42 \text{ [s]}$$

LE2S16□H/Vertical

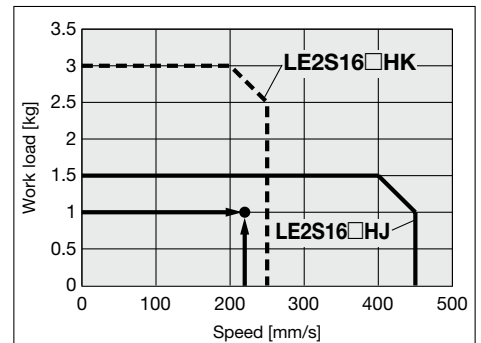

<Speed-Work load graph>

Step 3 Check the allowable moment. <Static allowable moment> (page 87)

<Dynamic allowable moment> (pages 88, 89)

Confirm the moment that applies to the actuator is within the allowable range for both static and dynamic conditions.

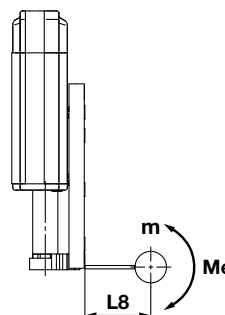

LE2S16□H/Pitching

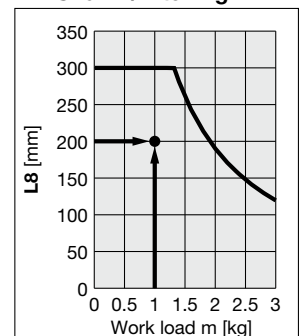

<Dynamic allowable moment>

Based on the above calculation result, the LE2S16□HJ-50 should be selected.

Speed-Work Load Graph (Guide)

* The following graphs show the values when the moving force is 100%.

LE2S16□H

Horizontal

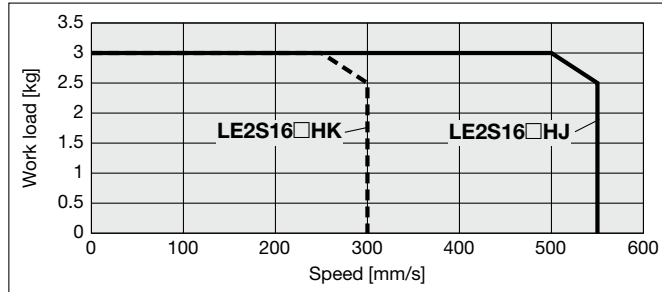

* When the power supply voltage is 24 V and the actuator cable length is 5 m

Vertical

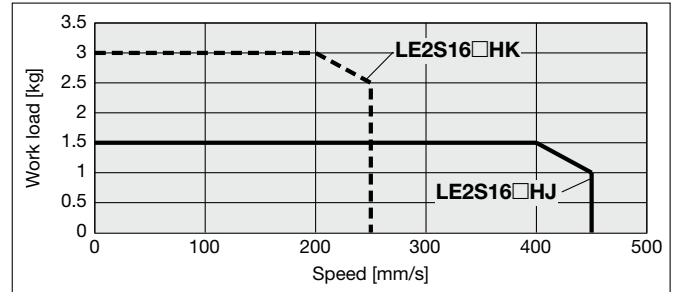

LE2S25□H

Horizontal

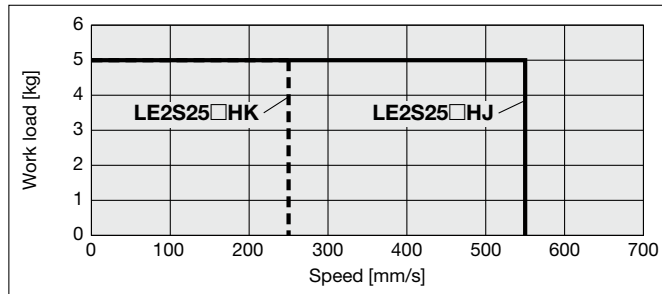

* When the power supply voltage is 24 V and the actuator cable length is 5 m

Vertical

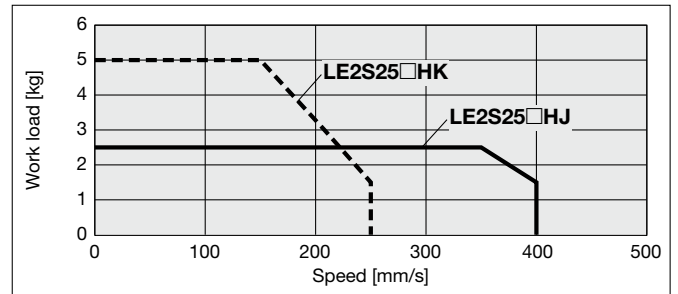

Model Selection

LE2FS□H

LE2FB□H

LE2Y□H

LE2YG□H

LE2S(H)□H

LE2R□H

Auto Switch

Cycle Time Graph (Guide)

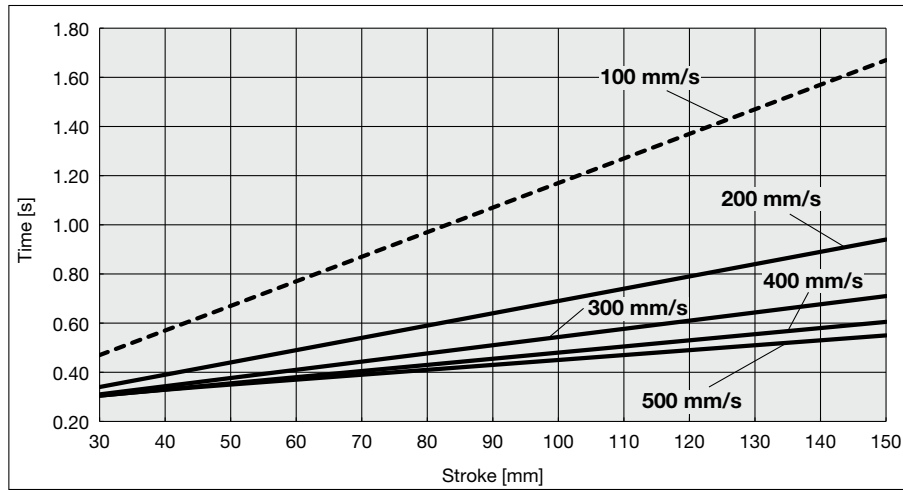

Operating Conditions

Acceleration/Deceleration: 5000 mm/s²

In position: 0.5 mm

Static Allowable Moment

Model		LE2S16□H	LE2S25□H
Pitching	[N·m]	4.8	14.1
Yawing	[N·m]	4.8	14.1
Rolling	[N·m]	1.8	4.8

* These graphs show the amount of allowable overhang (guide unit) when the center of gravity of the workpiece overhangs in one direction. When selecting the overhang, refer to the "Calculation of Guide Load Factor" or the Electric Actuator Model Selection Software for confirmation: <https://www.smcworld.com>

Dynamic Allowable Moment

Acceleration/Deceleration — 5000 mm/s²

Orientation	Load overhanging direction m : Work load [kg] Me: Allowable moment [N·m] L : Overhang to the work load center of gravity [mm]	Model	
		LE2S16□H	LE2S25□H
Horizontal/Bottom	<p>X</p>		
	<p>Y</p>		
	<p>Z</p>		
Wall	<p>X</p>		
	<p>Y</p>		
	<p>Z</p>		

Model Selection

LE2FS□H

LE2FB□H

LE2Y□H

LE2YG□H

LE2S(H)□H

LE2R□H

Auto Switch

* These graphs show the amount of allowable overhang (guide unit) when the center of gravity of the workpiece overhangs in one direction. When selecting the overhang, refer to the "Calculation of Guide Load Factor" or the Electric Actuator Model Selection Software for confirmation: <https://www.smcworld.com>

Dynamic Allowable Moment

Acceleration/Deceleration — 5000 mm/s²

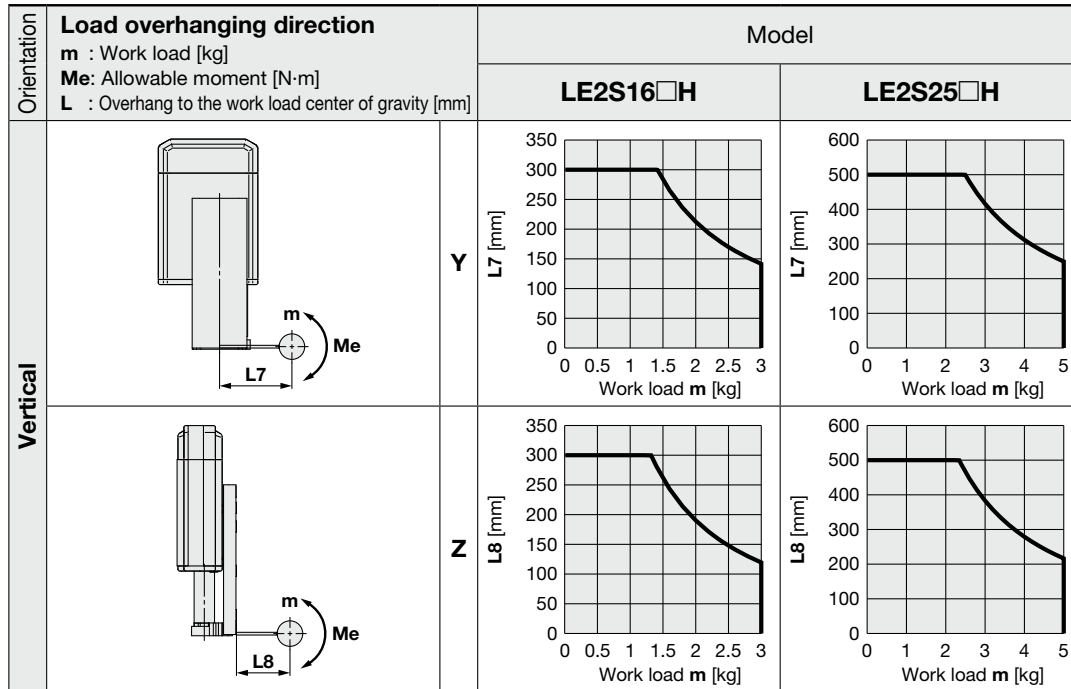

Calculation of Guide Load Factor

1. Decide operating conditions.

Model: LE2S□H

Size: 16/25

Mounting orientation: Horizontal/Bottom/Wall/Vertical

Acceleration [mm/s²]: a

Work load [kg]: m

Work load center position [mm]: Xc/Yc/Zc

2. Select the target graph while referencing the model, size, and mounting orientation.

3. Based on the acceleration and work load, find the overhang [mm]: Lx/Ly/Lz from the graph.

4. Calculate the load factor for each direction.

$$\alpha_x = X_c/L_x, \alpha_y = Y_c/L_y, \alpha_z = Z_c/L_z$$

5. Confirm the total of α_x , α_y , and α_z is 1 or less.

$$\alpha_x + \alpha_y + \alpha_z \leq 1$$

When 1 is exceeded, please consider a reduction of acceleration and work load, or a change of the work load center position and series.

Mounting orientation

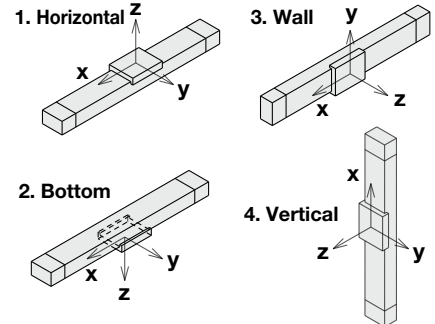

Example

1. Operating conditions

Model: LE2S□H

Size: 16

Mounting orientation: Horizontal

Acceleration [mm/s²]: 5000

Work load [kg]: 1.6

Work load center position [mm]: Xc = 50, Yc = 30, Zc = 60

2. Select three graphs from the top of the left side first row on page 88.

3. Lx = 152 mm, Ly = 115 mm, Lz = 300 mm

4. The load factor for each direction can be found as follows.

$$\alpha_x = 50/152 = 0.33$$

$$\alpha_y = 30/115 = 0.26$$

$$\alpha_z = 60/300 = 0.2$$

5. $\alpha_x + \alpha_y + \alpha_z = 0.79 \leq 1$

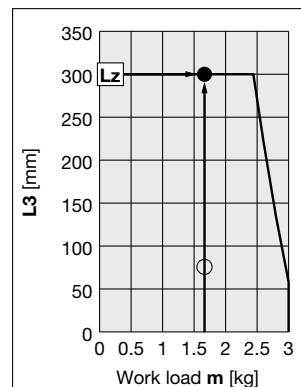
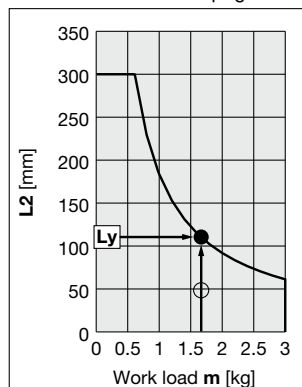
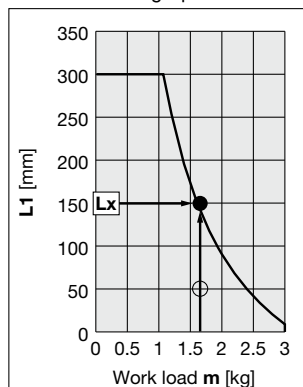

Model Selection 2



LE2S□H Series ▶ p. 94

Selection Procedure For the high rigidity type LE2SH□H series, refer to page 108.



Selection Example

Operating conditions

- Pushing force: 90 [N]
- Workpiece mass: 1 [kg]
- Speed: 100 [mm/s]
- Stroke: 100 [mm]
- Mounting orientation: Vertical upward

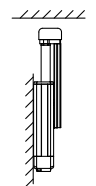

Step 1 Check the required force.

Calculate the approximate required force for a pushing operation.

Selection example) • Pushing force: 90 [N]
 • Workpiece mass: 1 [kg]
 The approximate required force can be found to be $90 + 10 = 100$ [N].

Select a model based on the approximate required force while referencing the specifications (page 95).

Selection example) Based on the specifications,
 • Approximate required force: 100 [N]
 • Speed: 100 [mm/s]
 The LE2S25□H can be temporarily selected as a possible candidate.

Then, calculate the required force for a pushing operation. If the mounting position is vertical upward, add the actuator table weight.

Selection example) Based on the table weight,
 • LE2S25□H table weight: 0.5 [kg]
 The required force can be found to be $100 + 5 = 105$ [N].

Step 2 Check the pushing force set value.

<Pushing force set value–Force graph> (page 91)

Select a model based on the required force while referencing the pushing force set value–force graph, and confirm the pushing force set value.

Selection example) Based on the graph shown on the right side,
 • Required force: 105 [N]
 The LE2S25□HK can be temporarily selected as a possible candidate.
 This pushing force set value is 40 [%].

Table Weight

[kg]

Model	Stroke [mm]					
	30	50	75	100	125	150
LE2S16□H	0.10	0.13	0.18	0.20	—	—
LE2S25□H	0.25	0.30	0.36	0.50	0.55	0.59

* If the mounting position is vertical upward, add the table weight.

LE2S25□H

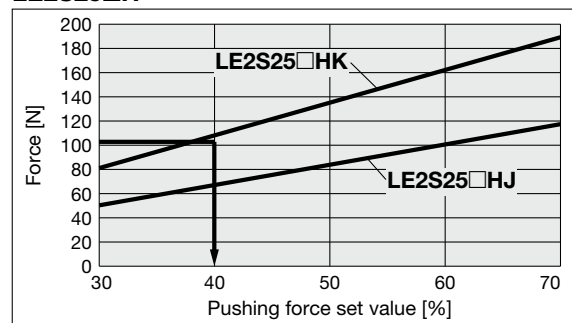

<Pushing force set value–Force graph>

Based on the above calculation result, the LE2S25□HK-100 should be selected.

For allowable moment, the selection procedure is the same as that for the positioning control.

Model Selection

LE2FS□H

LE2FB□H

LE2Y□H

LE2YG□H

LE2S(H)□H

LE2R□H

Auto Switch

Pushing Force Set Value–Force Graph (Guide)

LE2S16□H

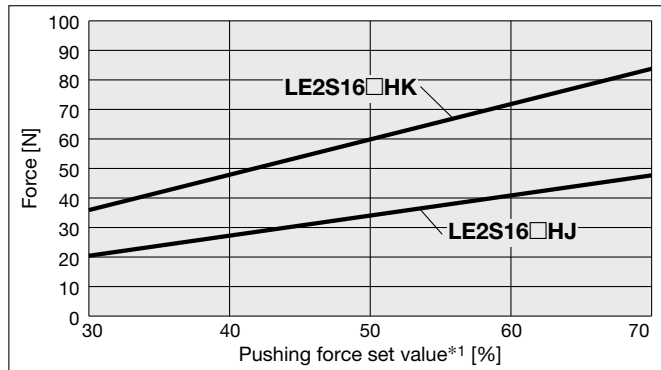

* When the power supply voltage is 24 V and the actuator cable length is 5 m

LE2S25□H

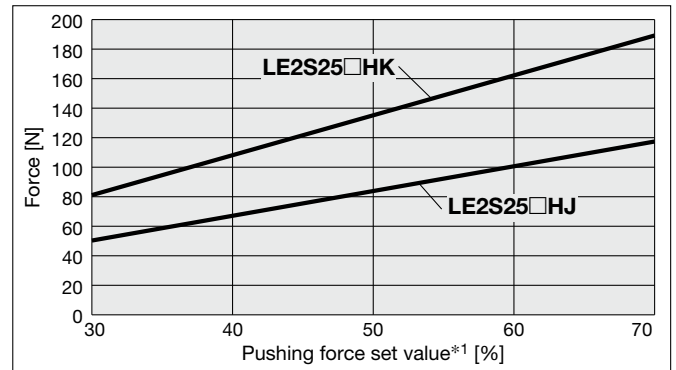

* When the power supply voltage is 24 V and the actuator cable length is 5 m

*1 Set values for the controller

Table Accuracy

* These values are initial guideline values.

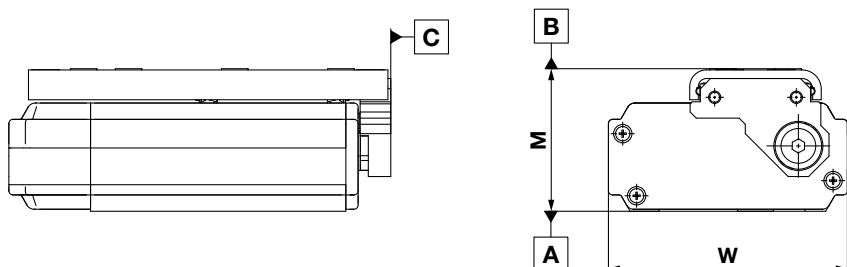

Model	LE2S16□H	LE2S25□H
B side parallelism to A side	0.4 mm	
B side traveling parallelism to A side	Refer to Graph 1.	
C side perpendicularity to A side	0.2 mm	
M dimension tolerance	±0.3 mm	
W dimension tolerance	±0.2 mm	

Graph 1 B side traveling parallelism to A side

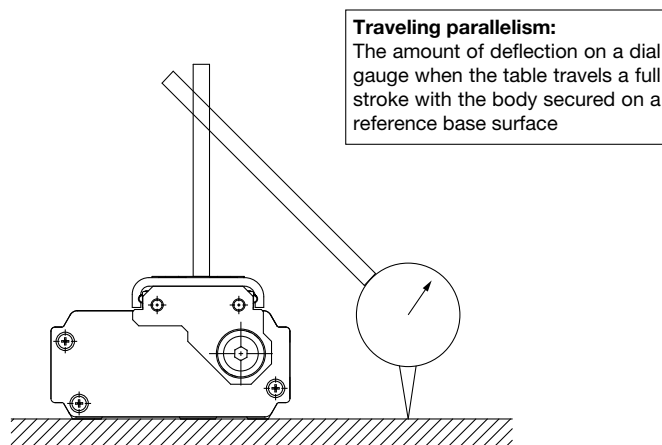
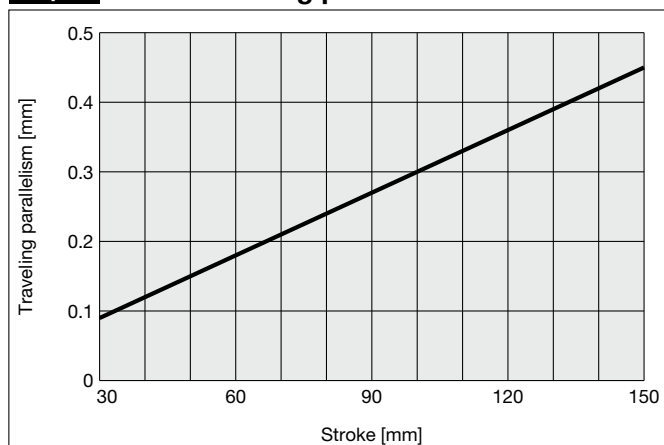

Model Selection

LE2FS□H

LE2FB□H

LE2Y□H

LE2YG□H

LE2S(H)□H

LE2R□H

Auto Switch

Table Deflection (Reference Value)

* These values are initial guideline values.

Pitching moment

Table displacement due to pitch moment load
Table displacement when loads are applied to the section marked with the arrow with the slide table stuck out.

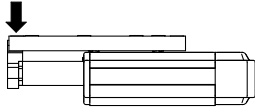

LE2S16□H

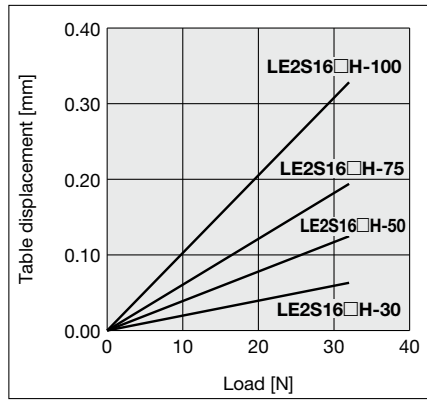

Yawing moment

Table displacement due to yaw moment load
Table displacement when loads are applied to the section marked with the arrow with the slide table stuck out.

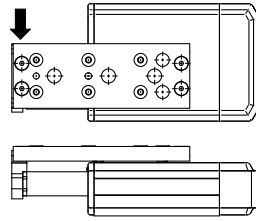

LE2S16□H

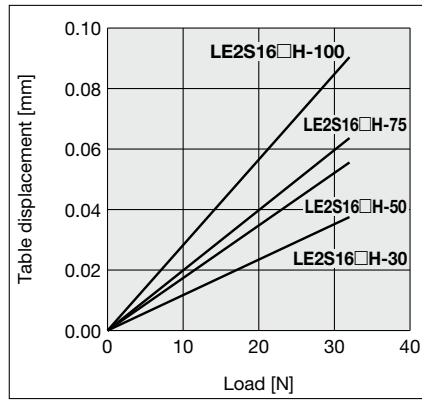

Rolling moment

Table displacement due to roll moment load
Table displacement of section A when loads are applied to the section F with the slide table retracted.

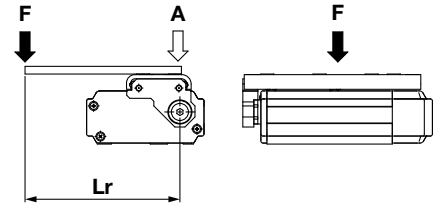

LE2S16□H

Lr = 60 mm

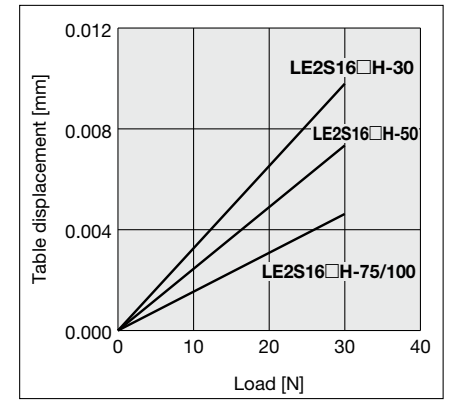

LE2S25□H

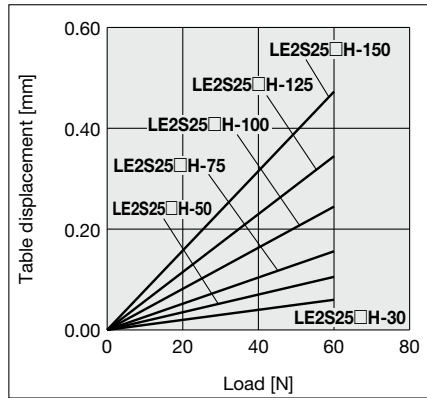

LE2S25□H

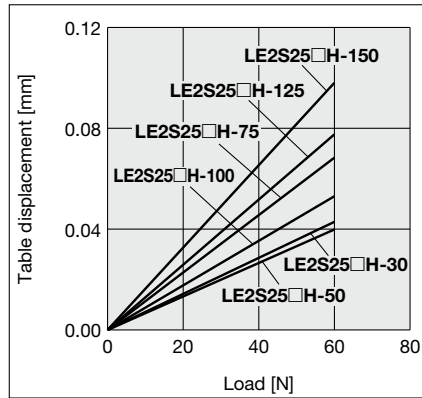

LE2S25□H

Lr = 100 mm

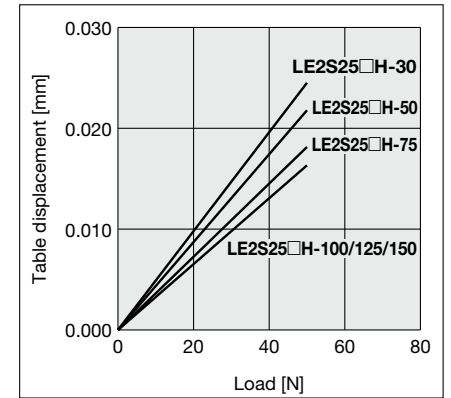

Compatible with Manifold Controller

Slide Table/Compact Type

LE2S□H Series LE2S16, 25□H



How to Order



Basic type (R type) Symmetrical type (L type) In-line motor type (D type)

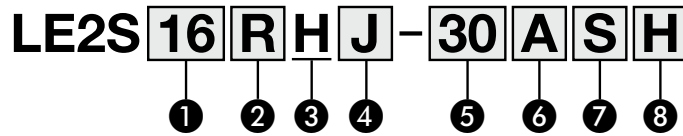

1 Size

16
25

2 Motor mounting position

R	Basic type/R type
L	Symmetrical type/L type
D	In-line motor type/D type

3 Motor type

Symbol	Type	Compatible controller
H	Battery-less absolute (Step motor 24 VDC)	JXD1

4 Lead [mm]

Symbol	LE2S16	LE2S25
J	10	16
K	5	8

5 Stroke [mm]

Stroke	Note	
	Size	Applicable stroke
30 to 100	16	30, 50, 75, 100
30 to 150	25	30, 50, 75, 100, 125, 150

* For details, refer to the applicable motor option chart.

6 Motor option

A	Without lock
B	With lock

7 Body option

Nil	Without option
S	Dust protected*1

*1 The following internal parts have been added: bushing, pulley gasket, end gasket, and scraper. For details, refer to the "Construction" page in the operation manual.

8 Mounting

Symbol	Mounting	R type L type	D type
Nil	Without side holder	●	●
H	With side holder (4 pcs.)	—	●

Applicable motor option chart

Motor mounting position	Size	Stroke		
		30	50	75 or more
R/L	16	x	x	○
	25	x	○	○
D	16	○	○	○
	25	○	○	○

Model Selection

LE2FS□H

LE2FB□H

LE2Y□H

LE2YG□H

LE2S(H)□H

LE2R□H

Auto Switch

Specifications

Model		LE2S16□H		LE2S25□H		
Actuator specifications	Stroke [mm]	30, 50, 75, 100		30, 50, 75, 100, 125, 150		
	Work load [kg] ^{*1}	Horizontal	3		5	
		Vertical	3	1.5	5	2.5
	Pushing force 30 to 70% [N] ^{*2 *3}		36 to 84	20 to 48	81 to 189	50 to 117
	Speed [mm/s] ^{*1 *3}	Horizontal	10 to 300	20 to 550	10 to 250	20 to 550
		Vertical	10 to 250	20 to 450	10 to 250	20 to 400
	Pushing speed [mm/s]		10 to 20	20	10 to 20	20
	Max. acceleration/deceleration [mm/s ²]		5000			
	Positioning repeatability [mm]		±0.05			
	Lost motion [mm] ^{*4}		0.3 or less			
	Screw lead [mm]		5	10	8	16
	Impact/Vibration resistance [m/s ²] ^{*5}		50/20			
	Actuation type		Slide screw + Belt (R/L type), Slide screw (D type)			
	Guide type		Linear guide (Circulating type)			
Operating temperature range [°C]		5 to 40				
Operating humidity range [%RH]		90 or less (No condensation)				
Enclosure		IP30				
Electric specifications	Motor size	□28		□42		
	Motor type	Battery-less absolute (Step motor 24 VDC)				
	Encoder	Battery-less absolute				
	Power supply voltage [V]	24 VDC ±10%				
	Power [W] ^{*6 *8}	Max. power 69		Max. power 76		
Lock unit specifications	Type ^{*6}	Non-magnetizing lock				
	Holding force [N]	30	15	49	25	
		4		8		
	Rated voltage [V]	24 VDC ±10%				

*1 Speed changes according to the work load. Check the "Speed-Work Load Graph (Guide)" on page 86.

*2 Pushing force accuracy is ±20% (F.S.).

*3 The speed and force may change depending on the cable length, load, and mounting conditions. Furthermore, if the cable length exceeds 5 m, then it will decrease by up to 10% for each 5 m. (At 15 m: Reduced by up to 20%)

*4 A reference value for correcting errors in reciprocal operation

*5 Impact resistance: No malfunction occurred when the actuator was tested with a drop tester in both an axial direction and a perpendicular direction to the lead screw. (The test was performed with the actuator in the initial state.)

Vibration resistance: No malfunction occurred in a test ranging between 45 to 2000 Hz. The test was performed in both an axial direction and a perpendicular direction to the lead screw. (The test was performed with the actuator in the initial state.)

*6 Indicates the max. power during operation (excluding the controller)

This value can be used for the selection of the power supply.

*7 With lock only

*8 For an actuator with lock, add the power for the lock.

Weight

Model	Basic type/R type, Symmetrical type/L type									
	LE2S16□H					LE2S25□H				
Stroke [mm]	30	50	75	100	30	50	75	100	125	150
Product weight [kg]	0.91	0.99	1.14	1.22	1.70	1.96	2.29	3.08	3.31	3.55
Additional weight with lock [kg]	—		0.13		—		0.27			

Model	In-line motor type/D type									
	LE2S16DH					LE2S25DH				
Stroke [mm]	30	50	75	100	30	50	75	100	125	150
Product weight [kg]	0.78	0.91	1.12	1.21	1.75	1.98	2.28	3.00	3.20	3.40
Additional weight with lock [kg]	0.13					0.28				

Dimensions: Basic Type/R Type

LE2S16RH

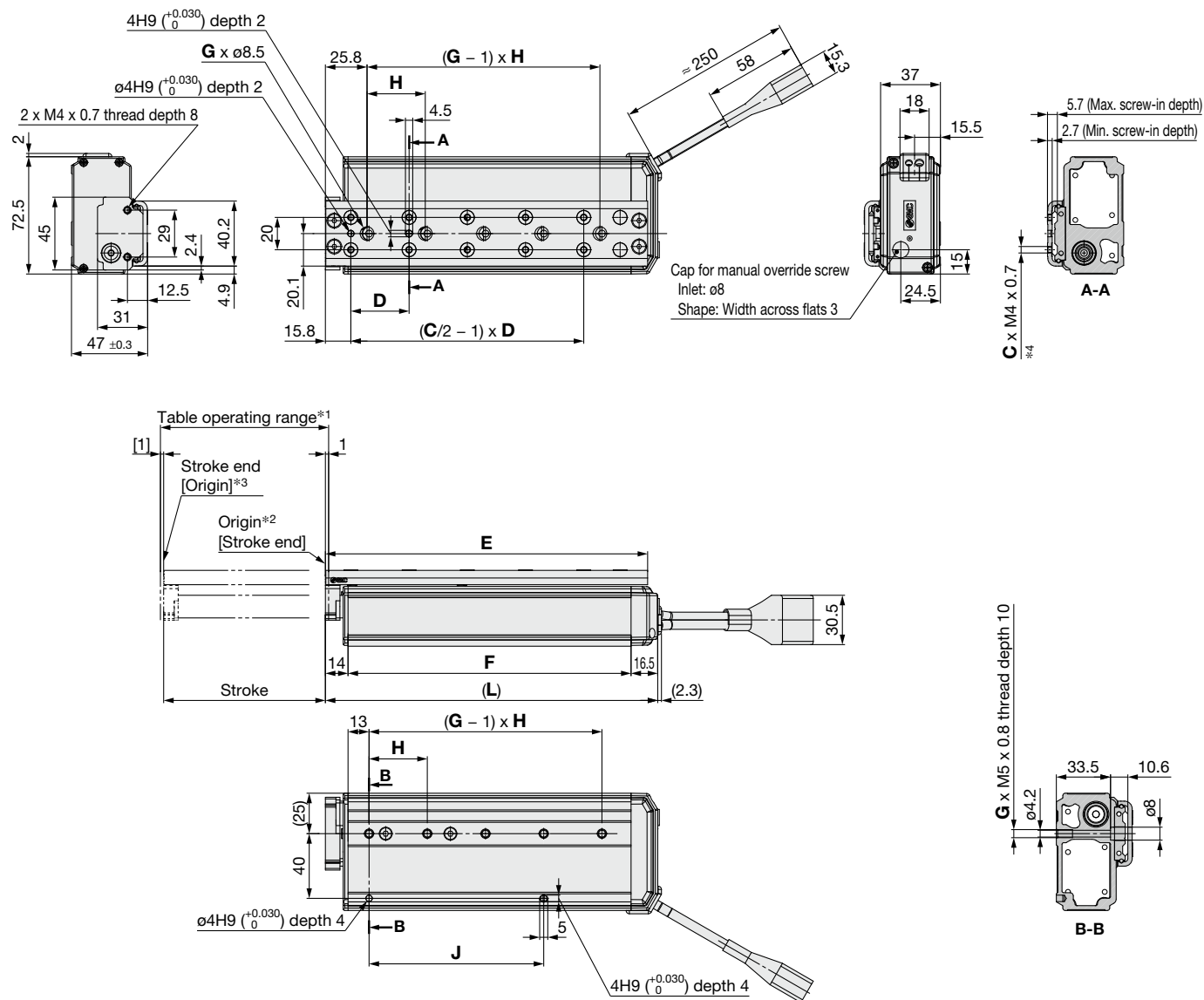

- *1 This is the range within which the table can move when it returns to origin.
Make sure that workpieces mounted on the table do not interfere with other workpieces or the facilities around the table.
- *2 Position after returning to origin
- *3 [] for when the direction of return to origin has changed
- *4 If the workpiece retaining screws are too long, they may come in contact with the guide block, resulting in a malfunction.
Use screws that are between the maximum and minimum screw-in depths in length.

Dimensions	[mm]							
Model	L	C	D	E	F	G	H	J
LE2S16RH□-30A□	112	4	38	102.3	81.5	2	40	40
LE2S16RH□-50A□	136.5	6	34	130.3	106	2	78	78
LE2S16RH□-75□□	180.5	8	36	174.3	150	4	36	72
LE2S16RH□-100□□	205.5	10	36	199.3	175	5	36	108

Model Selection

LE2FS□H

LE2FB□H

LE2Y□H

LE2YG□H

LE2S(H)□H

LE2R□H

Auto Switch

Dimensions: Basic Type/R Type

LE2S25RH

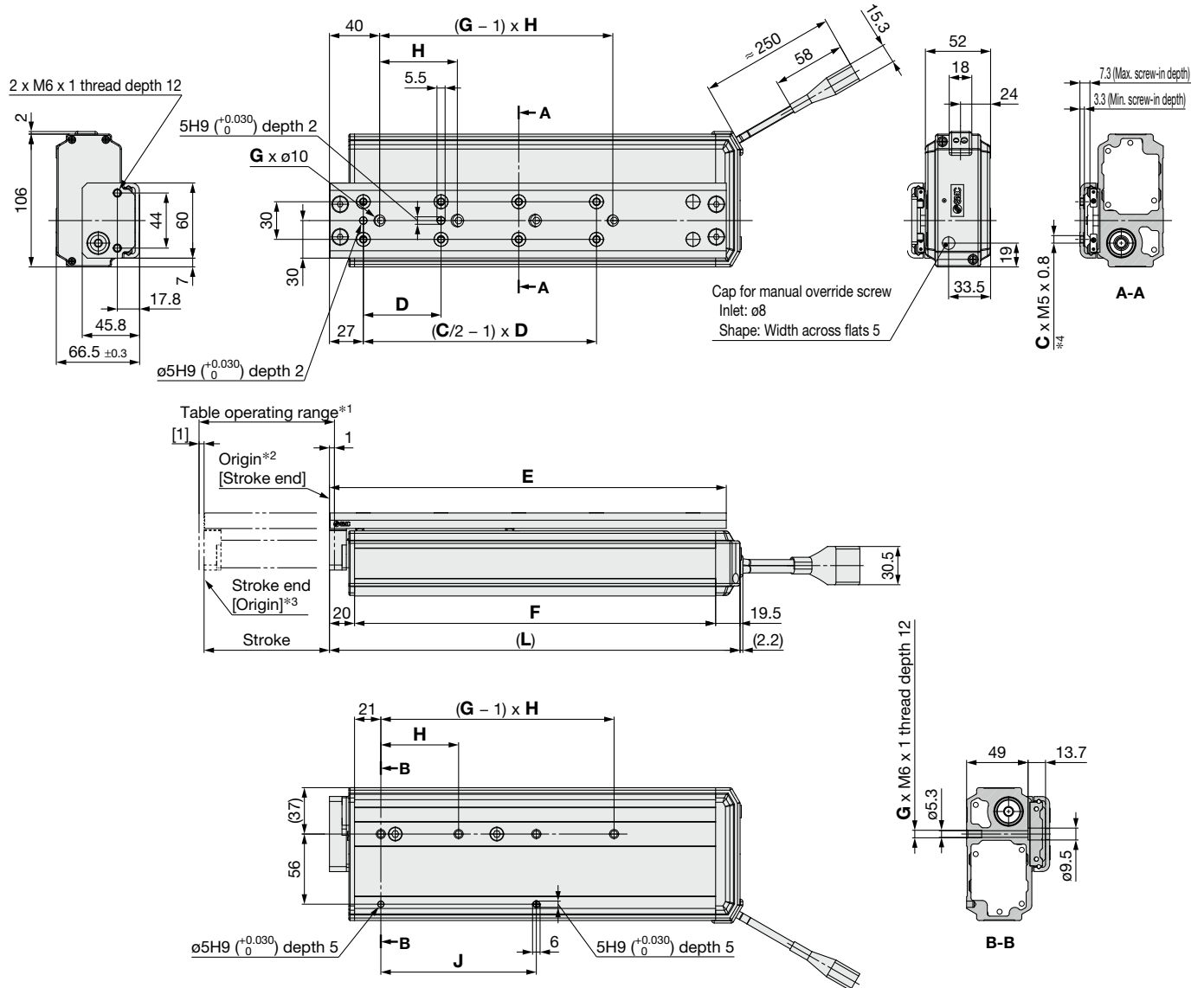

- *1 This is the range within which the table can move when it returns to origin.
Make sure that workpieces mounted on the table do not interfere with other workpieces or the facilities around the table.
- *2 Position after returning to origin
- *3 [] for when the direction of return to origin has changed
- *4 If the workpiece retaining screws are too long, they may come in contact with the guide block, resulting in a malfunction.
Use screws that are between the maximum and minimum screw-in depths in length.

Dimensions [mm]

Model	L	C	D	E	F	G	H	J
LE2S25RH□-30A□	144.5	4	48	133.5	105	2	46	46
LE2S25RH□-50□□	170.5	6	42	159.5	131	2	84	84
LE2S25RH□-75□□	204.5	6	55	193.5	165	2	112	112
LE2S25RH□-100□□	277.5	8	50	266.5	238	4	56	112
LE2S25RH□-125□□	302.5	8	55	291.5	263	4	59	118
LE2S25RH□-150□□	327.5	8	62	316.5	288	4	62	124

Dimensions: Symmetrical Type/L Type

LE2S16LH

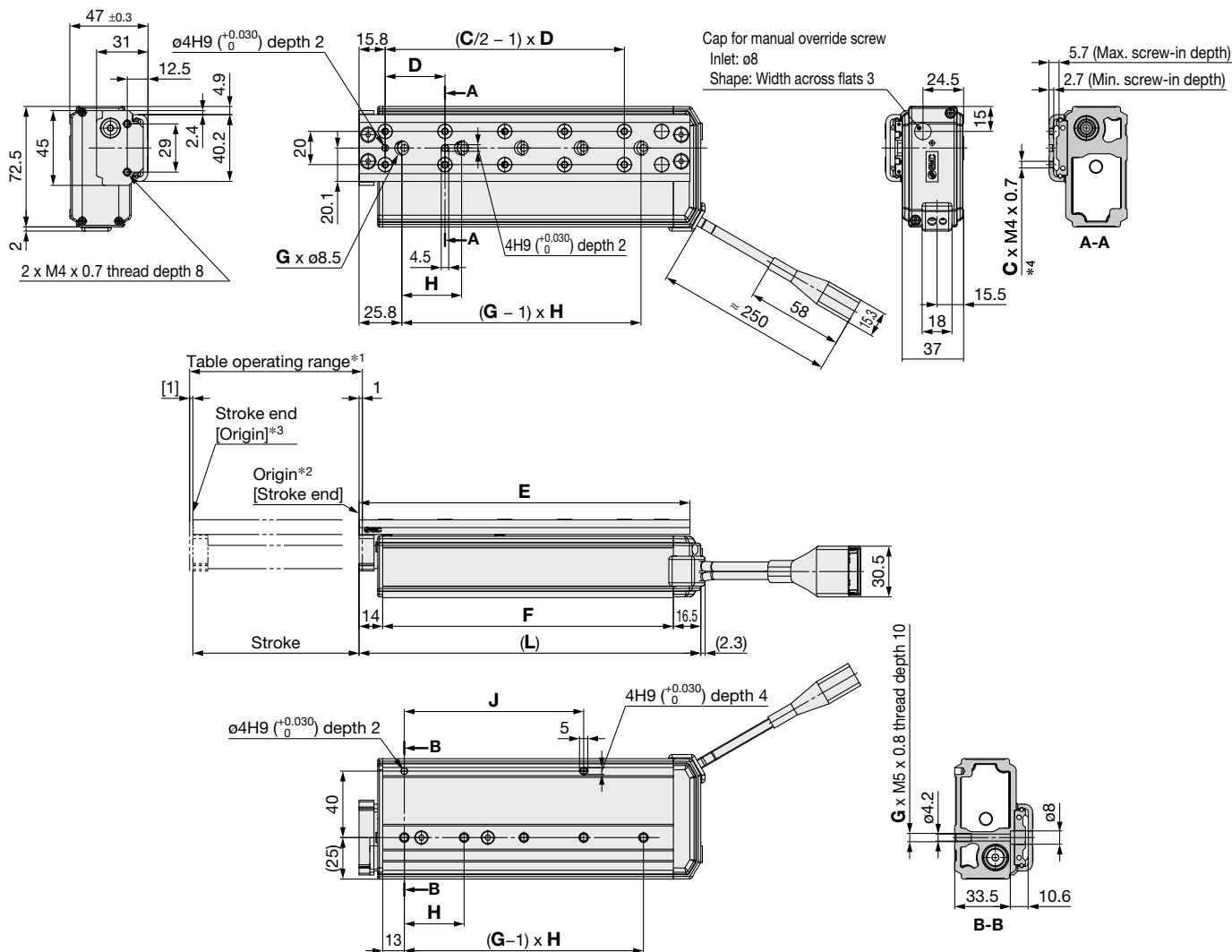

- *1 This is the range within which the table can move when it returns to origin.
Make sure that workpieces mounted on the table do not interfere with other workpieces or the facilities around the table.
- *2 Position after returning to origin
- *3 [] for when the direction of return to origin has changed
- *4 If the workpiece retaining screws are too long, they may come in contact with the guide block, resulting in a malfunction.
Use screws that are between the maximum and minimum screw-in depths in length.

Dimensions	[mm]								
Model	L	C	D	E	F	G	H	J	
LE2S16LH□-30A□	112	4	38	102.3	81.5	2	40	40	
LE2S16LH□-50A□	136.5	6	34	130.3	106	2	78	78	
LE2S16LH□-75□□	180.5	8	36	174.3	150	4	36	72	
LE2S16LH□-100□□	205.5	10	36	199.3	175	5	36	108	

Model Selection

LE2FS□H

LE2FB□H

LE2Y□H

LE2YG□H

LE2S(H)□H

LE2R□H

Auto Switch

Dimensions: Symmetrical Type/L Type

LE2S25LH

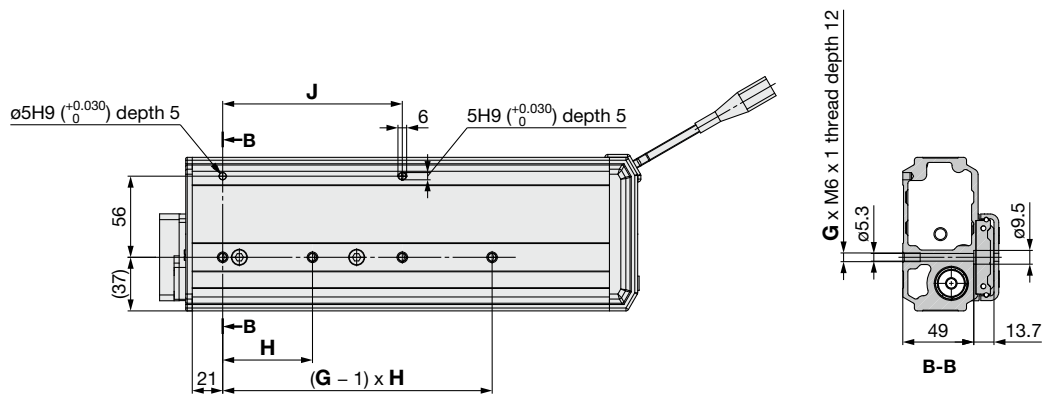
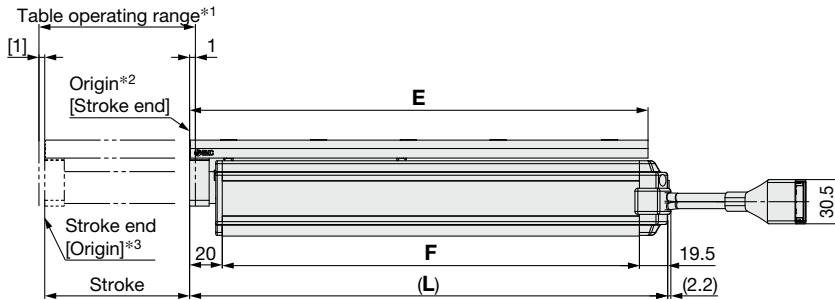
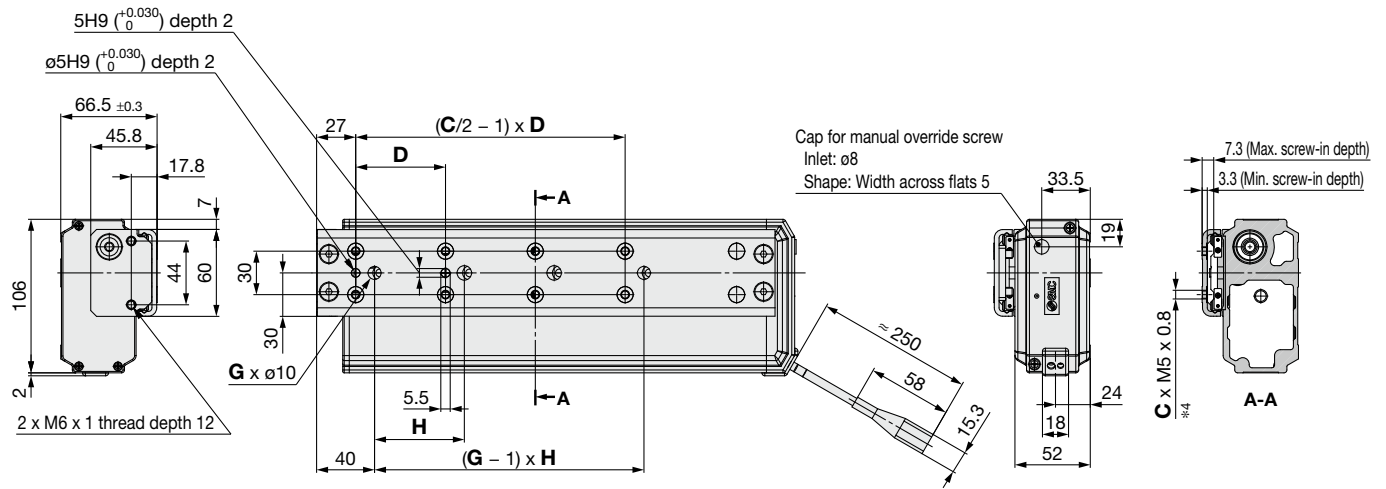

- *1 This is the range within which the table can move when it returns to origin.
Make sure that workpieces mounted on the table do not interfere with other workpieces or the facilities around the table.
- *2 Position after returning to origin
- *3 [] for when the direction of return to origin has changed
- *4 If the workpiece retaining screws are too long, they may come in contact with the guide block, resulting in a malfunction.
Use screws that are between the maximum and minimum screw-in depths in length.

Dimensions

[mm]

Model	L	C	D	E	F	G	H	J
LE2S25LH□-30A□	144.5	4	48	133.5	105	2	46	46
LE2S25LH□-50□□	170.5	6	42	159.5	131	2	84	84
LE2S25LH□-75□□	204.5	6	55	193.5	165	2	112	112
LE2S25LH□-100□□	277.5	8	50	266.5	238	4	56	112
LE2S25LH□-125□□	302.5	8	55	291.5	263	4	59	118
LE2S25LH□-150□□	327.5	8	62	316.5	288	4	62	124

Dimensions: In-line Motor Type/D Type

LE2S16DH

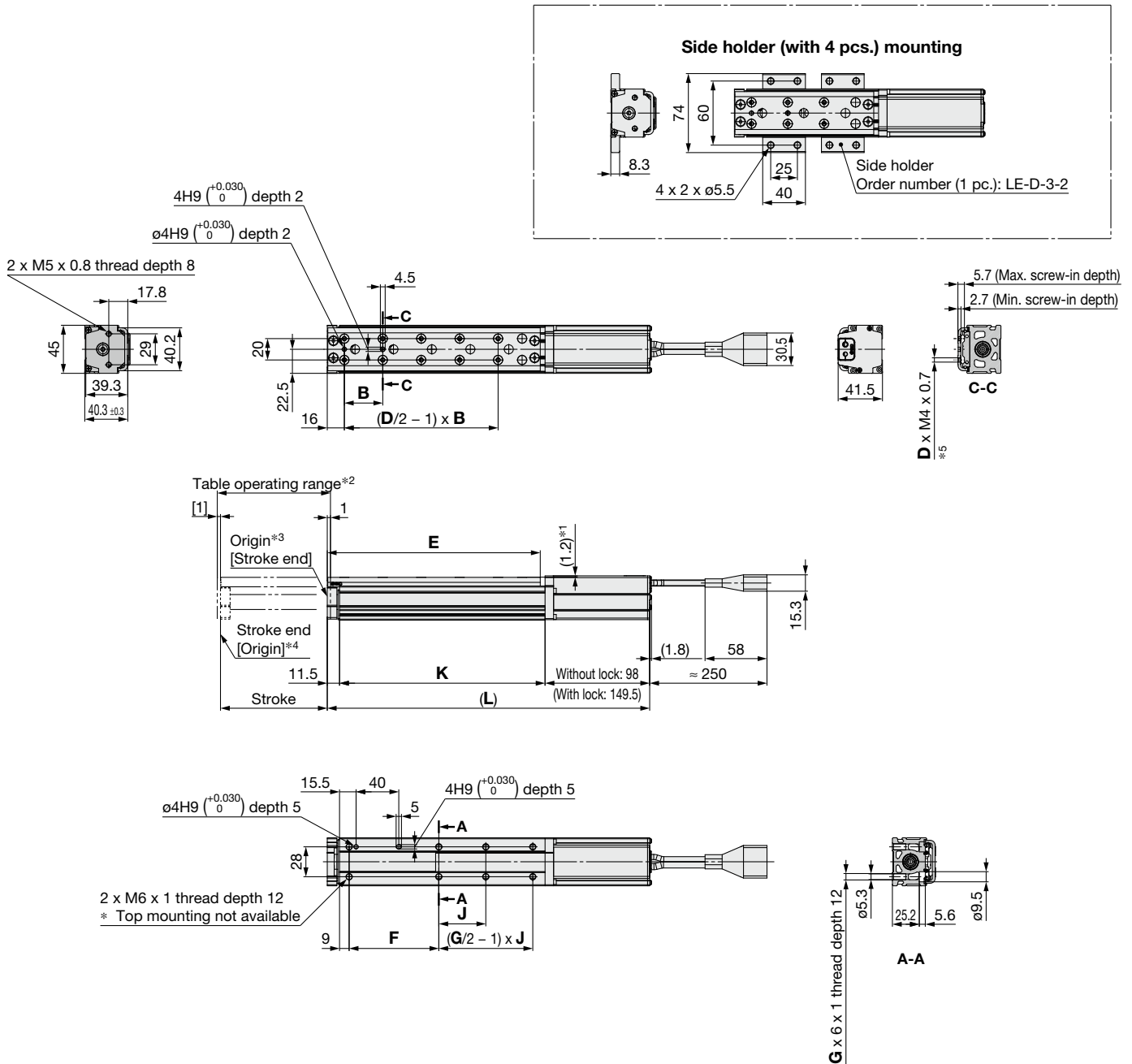

- *1 The table is lower than the motor cover. Make sure it does not interfere with the workpiece.
- *2 This is the range within which the table can move when it returns to origin. Make sure that workpieces mounted on the table do not interfere with other workpieces or the facilities around the table.
- *3 Position after returning to origin
- *4 [] for when the direction of return to origin has changed
- *5 If the workpiece retaining screws are too long, they may come in contact with the guide block, resulting in a malfunction. Use screws that are between the maximum and minimum screw-in depths in length.

Model	(L)	B	D	E	F	G	J	K
LE2S16DH□-30A□□	205	38	4	102.5	56.5	4	18.5	95.5
LE2S16DH□-30B□□	256.5							
LE2S16DH□-50A□□	233	34	6	130.5	65	4	38	123.5
LE2S16DH□-50B□□	284.5							
LE2S16DH□-75A□□	277	36	8	174.5	84	4	63	167.5
LE2S16DH□-75B□□	328.5							
LE2S16DH□-100A□□	302	36	10	199.5	84	6	44	192.5
LE2S16DH□-100B□□	353.5							

Dimensions: In-line Motor Type/D Type

LE2S25DH

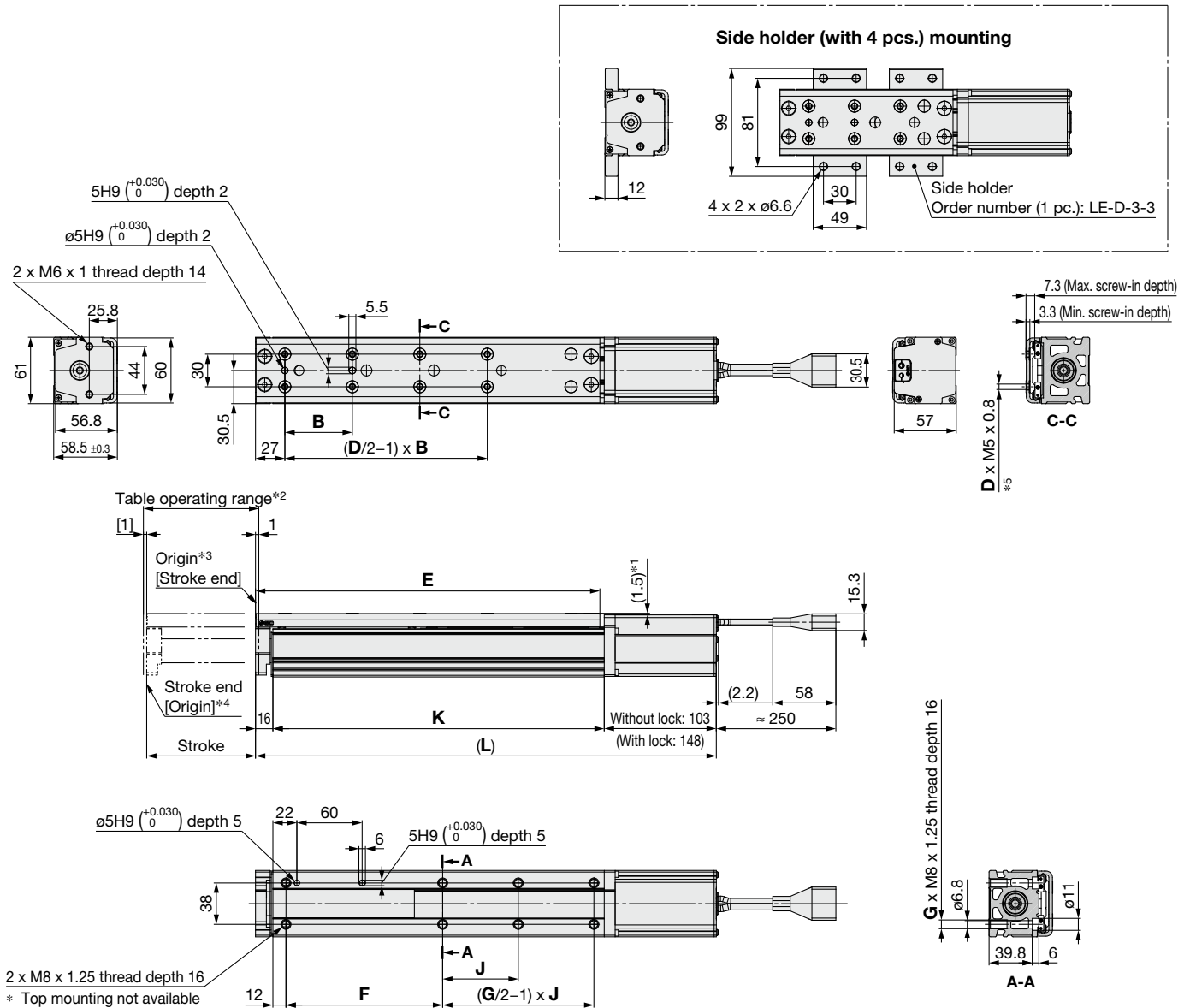

- *1 The table is lower than the motor cover.
- *2 This is the range within which the table can move when it returns to origin. Make sure that workpieces mounted on the table do not interfere with other workpieces or the facilities around the table.
- *3 Position after returning to origin
- *4 [] for when the direction of return to origin has changed
- *5 If the workpiece retaining screws are too long, they may come in contact with the guide block, resulting in a malfunction. Use screws that are between the maximum and minimum screw-in depths in length.

Dimensions

Model	(L)	B	D	E	F	G	J	K
LE2S25DH□-30A□□	240.5							
LE2S25DH□-30B□□	285.5	48	4	133.5	81	4	19	121.5
LE2S25DH□-50A□□	266.5	42	6	159.5	87	4	39	147.5
LE2S25DH□-50B□□	311.5							
LE2S25DH□-75A□□	300.5	55	6	193.5	96	4	64	181.5
LE2S25DH□-75B□□	345.5							
LE2S25DH□-100A□□	373.5	50	8	266.5	144	4	89	254.5
LE2S25DH□-100B□□	418.5							
LE2S25DH□-125A□□	398.5	55	8	291.5	144	6	57	279.5
LE2S25DH□-125B□□	443.5							
LE2S25DH□-150A□□	423.5	62	8	316.5	144	6	69.5	304.5
LE2S25DH□-150B□□	468.5							

Side Holder (For In-line Motor Type/D Type)

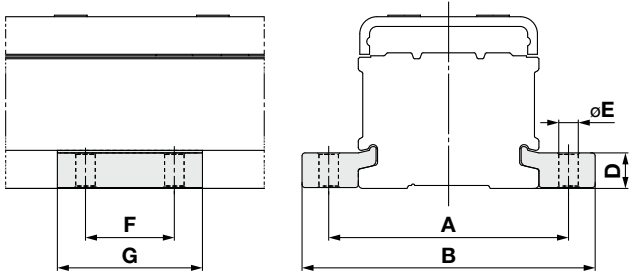

Part no.*1	A	B	D	E	F	G	Applicable model
LE-D-3-2	60	74	8.3	5.5	25	40	LE2S16DH
LE-D-3-3	81	99	12	6.6	30	49	LE2S25DH

*1 Part numbers for 1 side holder

Model Selection

LE2FS□H

LE2FB□H

LE2Y□H

LE2YG□H

LE2S(H)□H

LE2R□H

Auto Switch

Model Selection 1



LE2SH□H Series ▶ p. 112

Selection Procedure

For the compact type LE2S□H series, refer to page 85.



Selection Example

Step 1 Check the work load-speed. <Speed-Work load graph> (page 104)
 Select a model based on the workpiece mass and speed while referencing the speed-work load graph.
 Selection example) The LE2SH16□HJ-50 can be temporarily selected as a possible candidate based on the graph shown on the right side.

Step 2 Check the cycle time.
 It is possible to find an approximate cycle time by using method 1, but if a more detailed cycle time is required, use method 2.

* Although it is possible to make a suitable selection by using method 1, this calculation is based on a maximum load condition. Therefore, if a more detailed selection for each load is required, use method 2.

Operating conditions

- Workpiece mass: 1 [kg]
- Workpiece mounting condition:
- Speed: 220 [mm/s]
- Mounting orientation: Vertical
- Stroke: 50 [mm]
- Acceleration/Deceleration: 5000 [mm/s²]
- Cycle time: 0.5 s

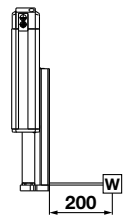

Method 1: Check the cycle time graph. (page 105)

Method 2: Calculation <Speed-Work load graph> (page 104)

Calculate the cycle time using the following calculation method. Calculation example
 T1 to T4 can be calculated as follows.

Cycle time:

T can be found from the following equation.

$$T = T1 + T2 + T3 + T4 \text{ [s]}$$

- T1: Acceleration time and T3: Deceleration time can be found by the following equation.

$$T1 = V/a1 \text{ [s]} \quad T3 = V/a2 \text{ [s]}$$

- T2: Constant speed time can be found from the following equation.

$$T2 = \frac{L - 0.5 \cdot V \cdot (T1 + T3)}{V} \text{ [s]}$$

- T4: Settling time varies depending on the conditions such as motor types, load, and in position of the step data. Therefore, calculate the settling time while referencing the following value.

$$T4 = 0.15 \text{ [s]}$$

$$T1 = V/a1 = 220/5000 = 0.04 \text{ [s]}$$

$$T3 = V/a2 = 220/5000 = 0.04 \text{ [s]}$$

$$T2 = \frac{L - 0.5 \cdot V \cdot (T1 + T3)}{V} = \frac{50 - 0.5 \cdot 220 \cdot (0.04 + 0.04)}{220} = 0.19 \text{ [s]}$$

$$T4 = 0.15 \text{ [s]}$$

The cycle time can be found as follows.

$$T = T1 + T2 + T3 + T4 = 0.04 + 0.19 + 0.04 + 0.15 = 0.42 \text{ [s]}$$

LE2SH16□H/Vertical

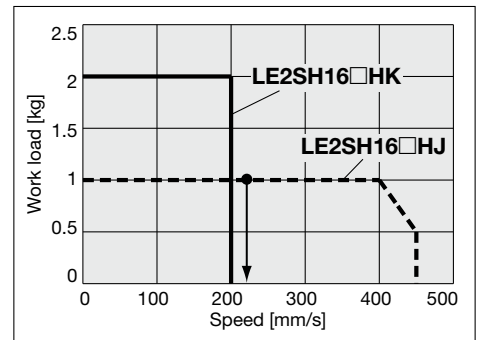

<Speed-Work load graph>

Step 3 Check the allowable moment. <Static allowable moment> (page 105)
 <Dynamic allowable moment> (pages 106, 107)

Confirm the moment that applies to the actuator is within the allowable range for both static and dynamic conditions.

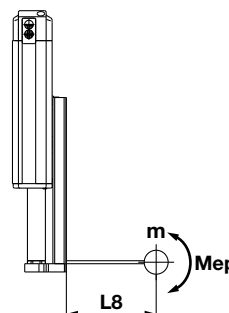

LE2SH16□H/Pitching

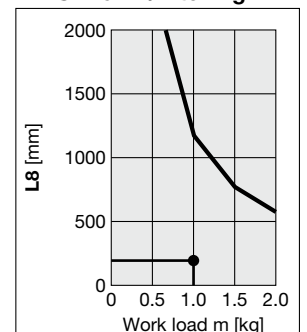

<Dynamic allowable moment>

Based on the above calculation result, the LE2SH16□HJ-50 should be selected.

Speed-Work Load Graph (Guide)

* The following graphs show the values when the moving force is 100%.

LE2SH16□H

Horizontal

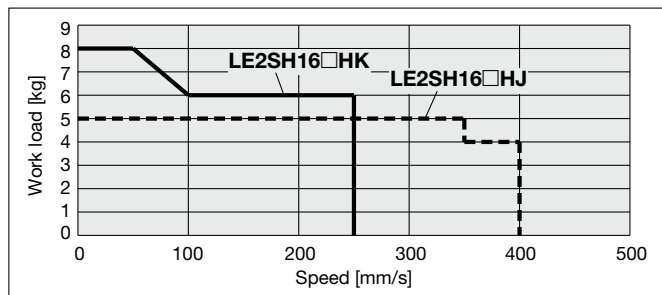

* When the power supply voltage is 24 V and the actuator cable length is 5 m

Vertical

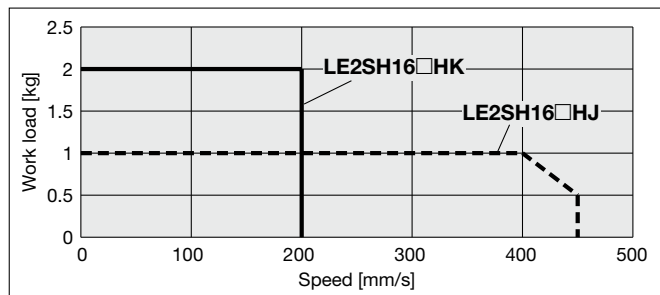

LE2SH25□H

Horizontal

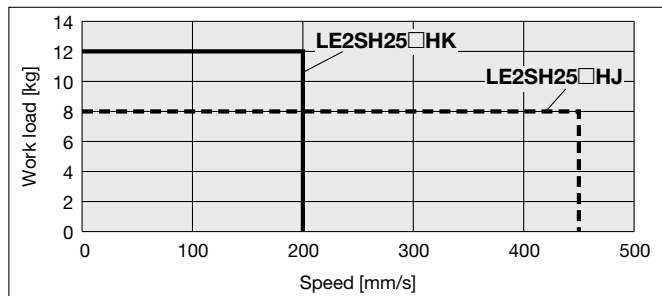

* When the power supply voltage is 24 V and the actuator cable length is 5 m

Vertical

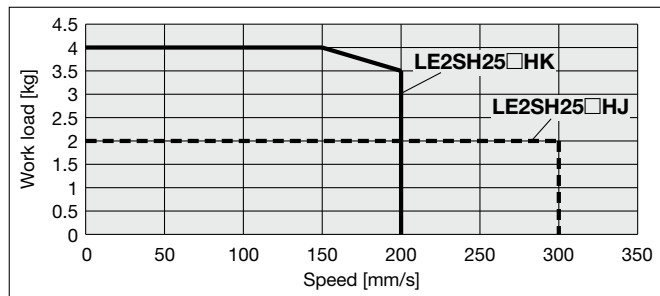

Model Selection

LE2FS□H

LE2FB□H

LE2Y□H

LE2YG□H

LE2S(H)□H

LE2R□H

Auto Switch

Cycle Time Graph (Guide)

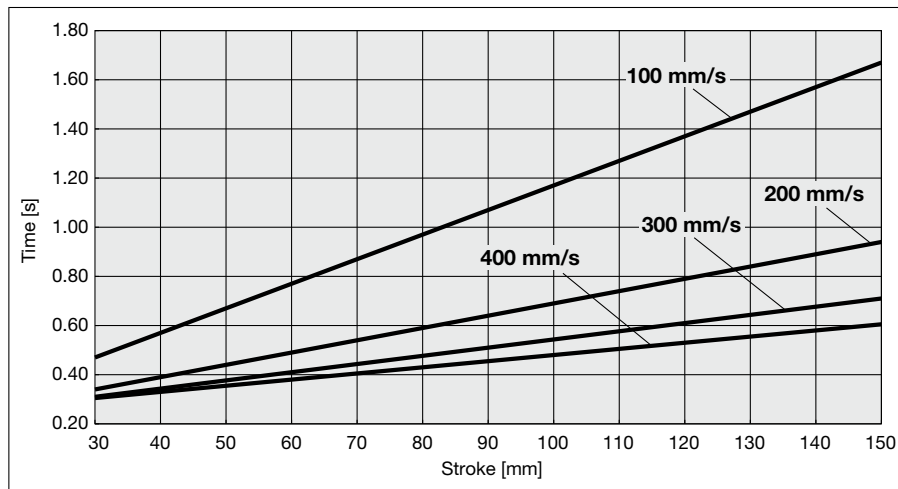

Operating Conditions

Acceleration/Deceleration: 5000 mm/s²

In position: 0.5 mm





Static Allowable Moment

Model		LE2SH16□H		LE2SH25□H		
Stroke	[mm]	50	100	50	100	150
Pitching	[N·m]	26	43	77	112	155
Yawing	[N·m]					
Rolling	[N·m]	48		146	177	152

* These graphs show the amount of allowable overhang (guide unit) when the center of gravity of the workpiece overhangs in one direction. When selecting the overhang, refer to the "Calculation of Guide Load Factor" or the Electric Actuator Model Selection Software for confirmation: <https://www.smcworld.com>

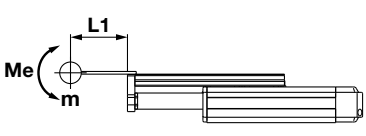
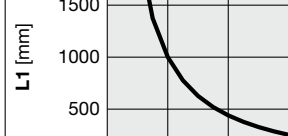
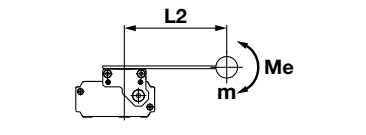
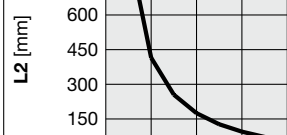
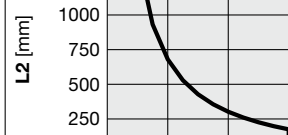
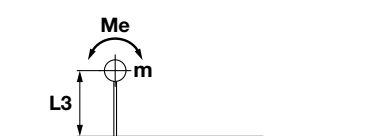
Dynamic Allowable Moment

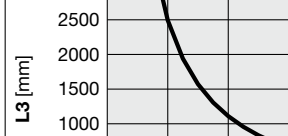
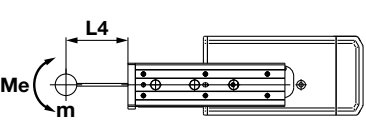
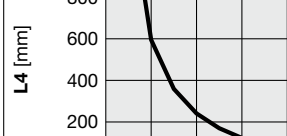
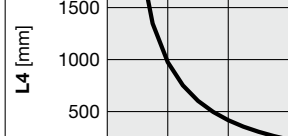
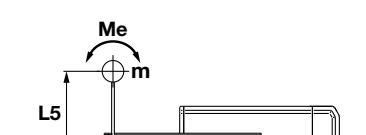
Acceleration/Deceleration — 5000 mm/s²

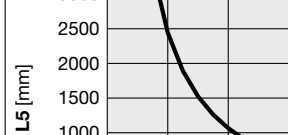
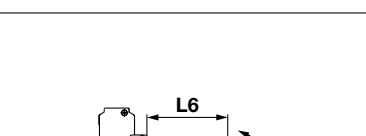
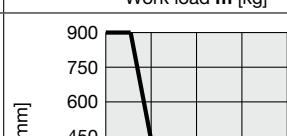
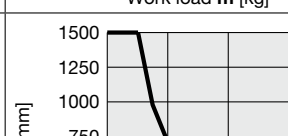
Orientation	Load overhanging direction m : Work load [kg] Me: Allowable moment [N·m] L : Overhang to the work load center of gravity [mm]	Model	
		LE2SH16□H	LE2SH25□H
Horizontal/Bottom	 X		
	 Y		
	 Z		
Horizontal (Wall)	 X		
	 Y		
	 Z		

- Model Selection
- LE2FS□H
- LE2FB□H
- LE2Y□H
- LE2YG□H
- LE2S(H)□H
- LE2R□H
- Auto Switch

* These graphs show the amount of allowable overhang (guide unit) when the center of gravity of the workpiece overhangs in one direction. When selecting the overhang, refer to the "Calculation of Guide Load Factor" or the Electric Actuator Model Selection Software for confirmation: <https://www.smcworld.com>

Dynamic Allowable Moment

Acceleration/Deceleration — 5000 mm/s²

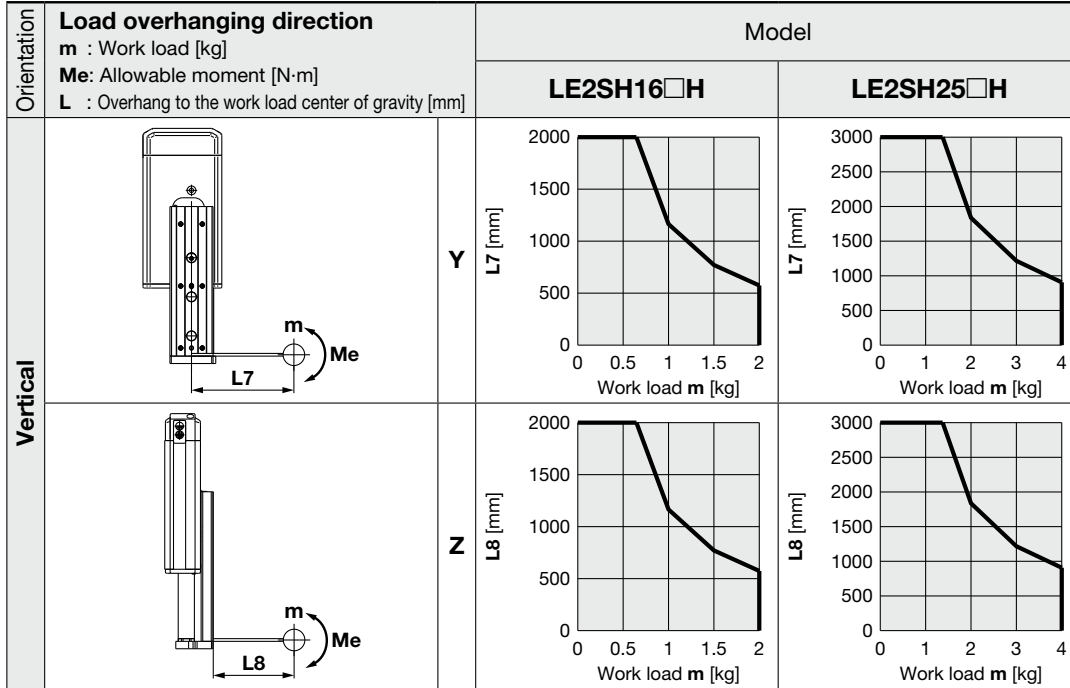

Calculation of Guide Load Factor

1. Decide operating conditions.

Model: LE2SH□H

Size: 16/25

Mounting orientation: Horizontal/Bottom/Wall/Vertical

Acceleration [mm/s²]: a

Work load [kg]: m

Work load center position [mm]: Xc/Yc/Zc

2. Select the target graph while referencing the model, size, and mounting orientation.

3. Based on the acceleration and work load, find the overhang [mm]: Lx/Ly/Lz from the graph.

4. Calculate the load factor for each direction.

$$\alpha_x = X_c/L_x, \alpha_y = Y_c/L_y, \alpha_z = Z_c/L_z$$

5. Confirm the total of α_x , α_y , and α_z is 1 or less.

$$\alpha_x + \alpha_y + \alpha_z \leq 1$$

When 1 is exceeded, please consider a reduction of acceleration and work load, or a change of the work load center position and series.

Mounting orientation

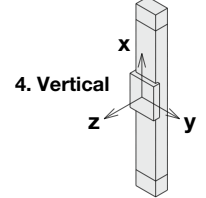
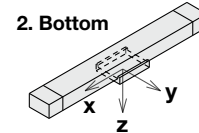
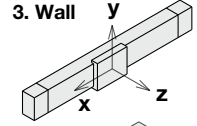
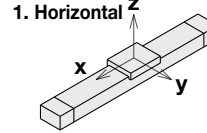

Example

1. Operating conditions

Model: LE2SH□H

Size: 16

Mounting orientation: Horizontal

Acceleration [mm/s²]: 5000

Work load [kg]: 4.0

Work load center position [mm]: Xc = 80, Yc = 100, Zc = 60

2. Select three graphs from the top of the left side first row on page 106.

3. Lx = 255 mm, Ly = 175 mm, Lz = 656 mm

4. The load factor for each direction can be found as follows.

$$\alpha_x = 80/255 = 0.31$$

$$\alpha_y = 100/177 = 0.57$$

$$\alpha_z = 60/656 = 0.09$$

5. $\alpha_x + \alpha_y + \alpha_z = 0.97 \leq 1$

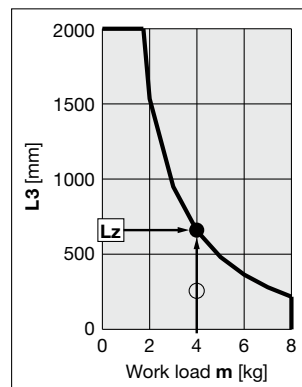
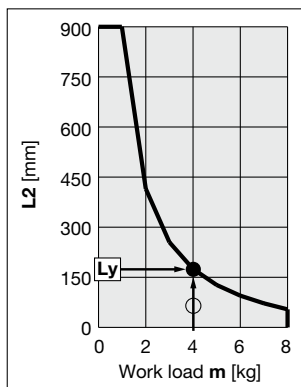
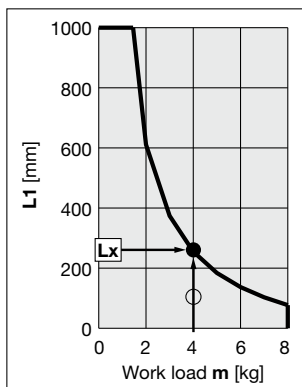

Model Selection 2



LE2SH□H Series ▶ p. 112

Selection Procedure For the compact type LE2S□H series, refer to page 90.



Selection Example

Operating conditions

- Pushing force: 90 [N]
- Workpiece mass: 1 [kg]
- Speed: 100 [mm/s]
- Stroke: 100 [mm]
- Mounting orientation: Vertical upward

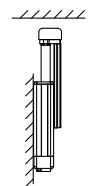

Step 1 Check the required force.

Calculate the approximate required force for a pushing operation.

Selection example) • Pushing force: 90 [N]
 • Workpiece mass: 1 [kg]
 The approximate required force can be found to be $90 + 10 = 100$ [N].

Select a model based on the approximate required force while referencing the specifications (page 113).

Selection example) Based on the specifications,
 • Approximate required force: 100 [N]
 • Speed: 100 [mm/s]
 The LE2SH25□H can be temporarily selected as a possible candidate.

Then, calculate the required force for a pushing operation. If the mounting position is vertical upward, add the actuator table weight.

Selection example) Based on the table weight,
 • LE2SH25□H table weight: 1.3 [kg]
 The required force can be found to be $100 + 13 = 113$ [N].

Step 2 Check the pushing force set value.

<Pushing force set value–Force graph> (page 109)

Select a model based on the required force while referencing the pushing force set value–force graph, and confirm the pushing force set value.

Selection example) Based on the graph shown on the right side,
 • Required force: 113 [N]
 The LE2SH25□HK can be temporarily selected as a possible candidate.
 This pushing force set value is 40 [%].

Table Weight

[kg]

Model	Stroke [mm]			
	50	75	100	150
LE2SH16□H	0.4	—	0.7	—
LE2SH25□H	0.9	—	1.3	1.7

* If the mounting position is vertical upward, add the table weight.

LE2SH25□H

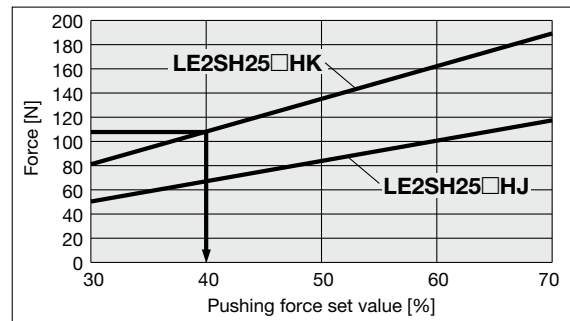

<Pushing force set value–Force graph>

Based on the above calculation result, the LE2SH25□HK-100 should be selected.

For allowable moment, the selection procedure is the same as that for the positioning control.

Model Selection

LE2FS□H

LE2FB□H

LE2Y□H

LE2YG□H

LE2S(H)□H

LE2R□H

Auto Switch

Pushing Force Set Value–Force Graph

LE2SH16□H

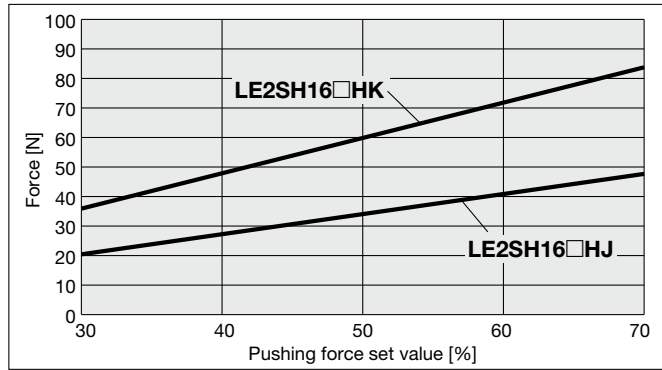

LE2SH25□H

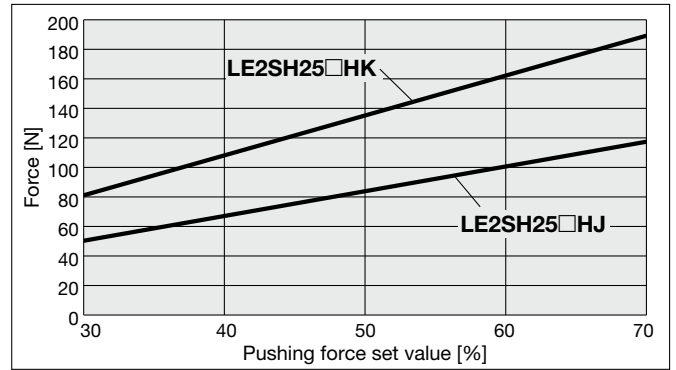
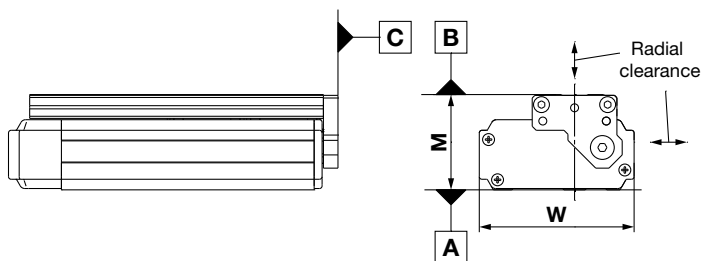

Table Accuracy

* These values are initial guideline values.



Model	LE2SH16□H	LE2SH25□H
B side parallelism to A side [mm]	Refer to Table 1.	
B side traveling parallelism to A side [mm]	Refer to Graph 1.	
C side perpendicularity to A side [mm]	0.05	0.05
M dimension tolerance [mm]	±0.3	
W dimension tolerance [mm]	±0.2	
Radial clearance [μm]	-10 to 0	-14 to 0

Table 1 B side parallelism to A side

Model	Stroke [mm]			
	50	75	100	150
LE2SH16□H	0.05	—	0.08	—
LE2SH25□H	0.06	—	0.08	0.125

Graph 1 B side traveling parallelism to A side

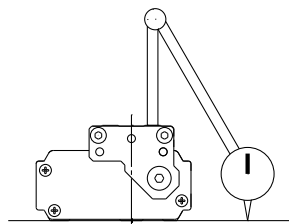
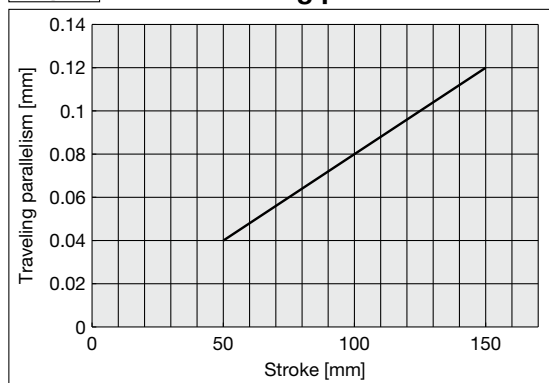

Traveling parallelism:
The amount of deflection on a dial gauge when the table travels a full stroke with the body secured on a reference base surface

Model Selection

LE2FS□H

LE2FB□H

LE2Y□H

LE2YG□H

LE2S(H)□H

LE2R□H

Auto Switch

Table Deflection (Reference Value)

* These values are initial guideline values.

Table displacement due to pitch moment load
Table displacement when loads are applied to the section marked with the arrow with the slide table stuck out.



LE2SH16□H

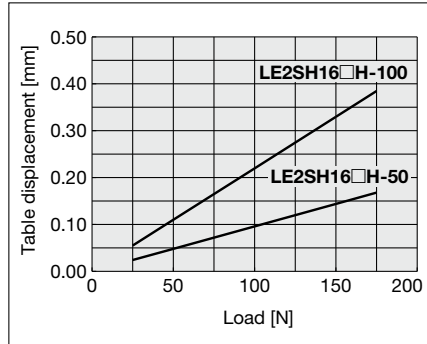
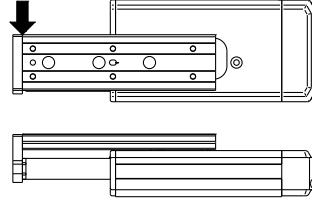

Table displacement due to yaw moment load
Table displacement when loads are applied to the section marked with the arrow with the slide table stuck out.



LE2SH16□H

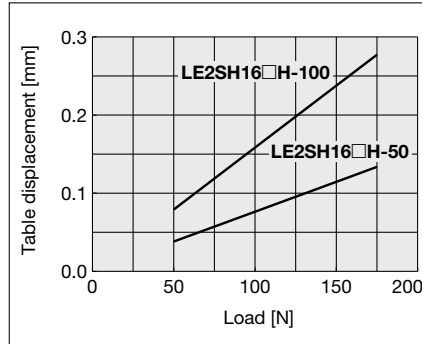
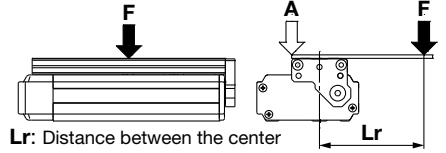

Table displacement due to roll moment load
Table displacement of section A when loads are applied to the section F with the slide table retracted.



Lr: Distance between the center of the table and the work load center of gravity

LE2SH16□H

Lr = 120 mm

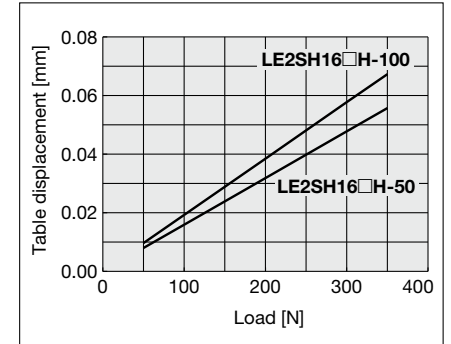

LE2SH25□H

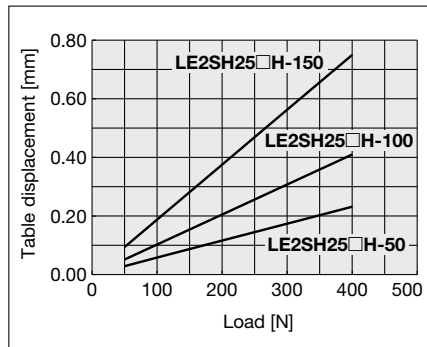

LE2SH25□H

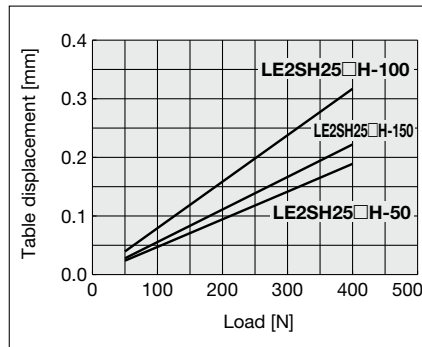

LE2SH25□H

Lr = 200 mm

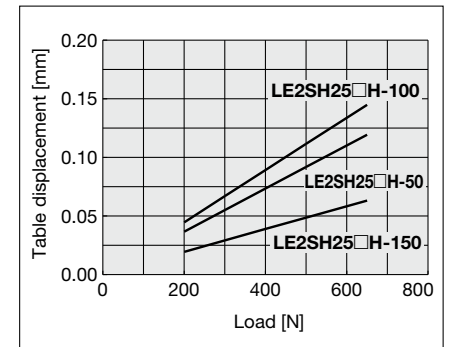

Compatible with Manifold Controller

Slide Table/High Rigidity Type

LE2SH□H Series LE2SH16, 25□H



How to Order



Basic type (R type) Symmetrical type (L type) In-line motor type (D type)

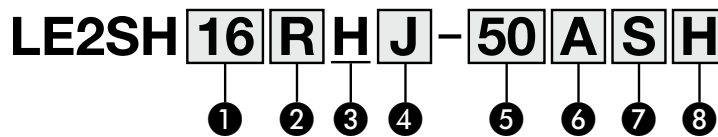

1 Size

16
25

2 Motor mounting position

R	Basic type/R type
L	Symmetrical type/L type
D	In-line motor type/D type

3 Motor type

Symbol	Type	Compatible controller
H	Battery-less absolute (Step motor 24 VDC)	JXD1

4 Lead [mm]

Symbol	LE2SH16	LE2SH25
J	10	16
K	5	8

5 Stroke [mm]

Stroke	Note	
	Size	Applicable stroke
50 to 100	16	50, 100
50 to 150	25	50, 100, 150

* For details, refer to the applicable motor option chart.

6 Motor option

A	Without lock
B	With lock

7 Body option

Nil	Without option
S	Dust protected*1

*1 The following internal parts have been added: bushing, pulley gasket, end gasket, and scraper. For details, refer to the "Construction" page in the operation manual.

8 Mounting

Symbol	Mounting	R type L type	D type
Nil	Without side holder	●	●
H	With side holder (4 pcs.)	—	●

Applicable motor option chart

Motor mounting position	Size	Stroke	
		50	100 or more
R/L	16	×	○
	25	○	○
D	16	○	○
	25	○	○

Model Selection

LE2FS□H

LE2FB□H

LE2Y□H

LE2YG□H

LE2S(H)□H

LE2R□H

Auto Switch

Specifications

Model		LE2SH16□H			LE2SH25□H		
Actuator specifications	Stroke [mm]	50, 100			50, 100, 150		
	Work load [kg]*1 *3	Horizontal	8	5	12	8	
		Vertical	2	1	4	2	
	Pushing force [N] 30% to 70%*2 *3	36 to 84	20 to 48	81 to 189	50 to 117		
	Speed [mm/s]*1 *3	Horizontal	10 to 250	20 to 400	10 to 200	20 to 450	
		Vertical	10 to 200	20 to 450	10 to 200	20 to 300	
	Pushing speed [mm/s]	10 to 20	20	10 to 20	20		
	Max. acceleration/deceleration [mm/s ²]	5000					
	Positioning repeatability [mm]	±0.05					
	Lost motion [mm]*4	0.15 or less					
	Screw lead [mm]	5	10	8	16		
	Impact/Vibration resistance [m/s ²]*5	50/20					
	Actuation type	Slide screw + Belt (R/L type), Slide screw (D type)					
	Guide type	Linear guide (Circulating type)					
Operating temperature range [°C]	5 to 40						
Operating humidity range [%RH]	90 or less (No condensation)						
Enclosure	IP30						
Electric specifications	Motor size	□28			□42		
	Motor type	Battery-less absolute (Step motor 24 VDC)					
	Encoder	Battery-less absolute					
	Power supply voltage [V]	24 VDC ±10%					
	Power [W]*6 *8	Max. power 74			Max. power 90		
Lock unit specifications	Type*6	Non-magnetizing lock					
	Holding force [N]	20	10	40	20		
	Power [W]*8	4			8		
	Rated voltage [V]	24 VDC ±10%					

*1 Speed changes according to the work load. Check the "Speed-Work Load Graph (Guide)" on page 104.

*2 Pushing force accuracy is ±20% (F.S.).

*3 The speed and force may change depending on the cable length, load, and mounting conditions. Furthermore, if the cable length exceeds 5 m, then it will decrease by up to 10% for each 5 m. (At 15 m: Reduced by up to 20%)

*4 A reference value for correcting errors in reciprocal operation

*5 Impact resistance: No malfunction occurred when the actuator was tested with a drop tester in both an axial direction and a perpendicular direction to the lead screw. (The test was performed with the actuator in the initial state.)

Vibration resistance: No malfunction occurred in a test ranging between 45 to 2000 Hz. The test was performed in both an axial direction and a perpendicular direction to the lead screw. (The test was performed with the actuator in the initial state.)

*6 Indicates the max. power during operation (excluding the controller)

This value can be used for the selection of the power supply.

*7 With lock only

*8 For an actuator with lock, add the power for the lock.

Weight

Model	Basic type/R type, Symmetrical type/L type					In-line motor type/D type				
	LE2SH16□H		LE2SH25□H			LE2SH16DH		LE2SH25DH		
Stroke [mm]	50	100	50	100	150	50	100	50	100	150
Product weight [kg]	1.14	1.58	2.41	3.15	3.47	1.26	1.71	2.43	3.23	4.19
Additional weight with lock [kg]	—	0.11	0.34			0.11		0.35		

Dimensions: Basic Type/R Type

LE2SH16RH

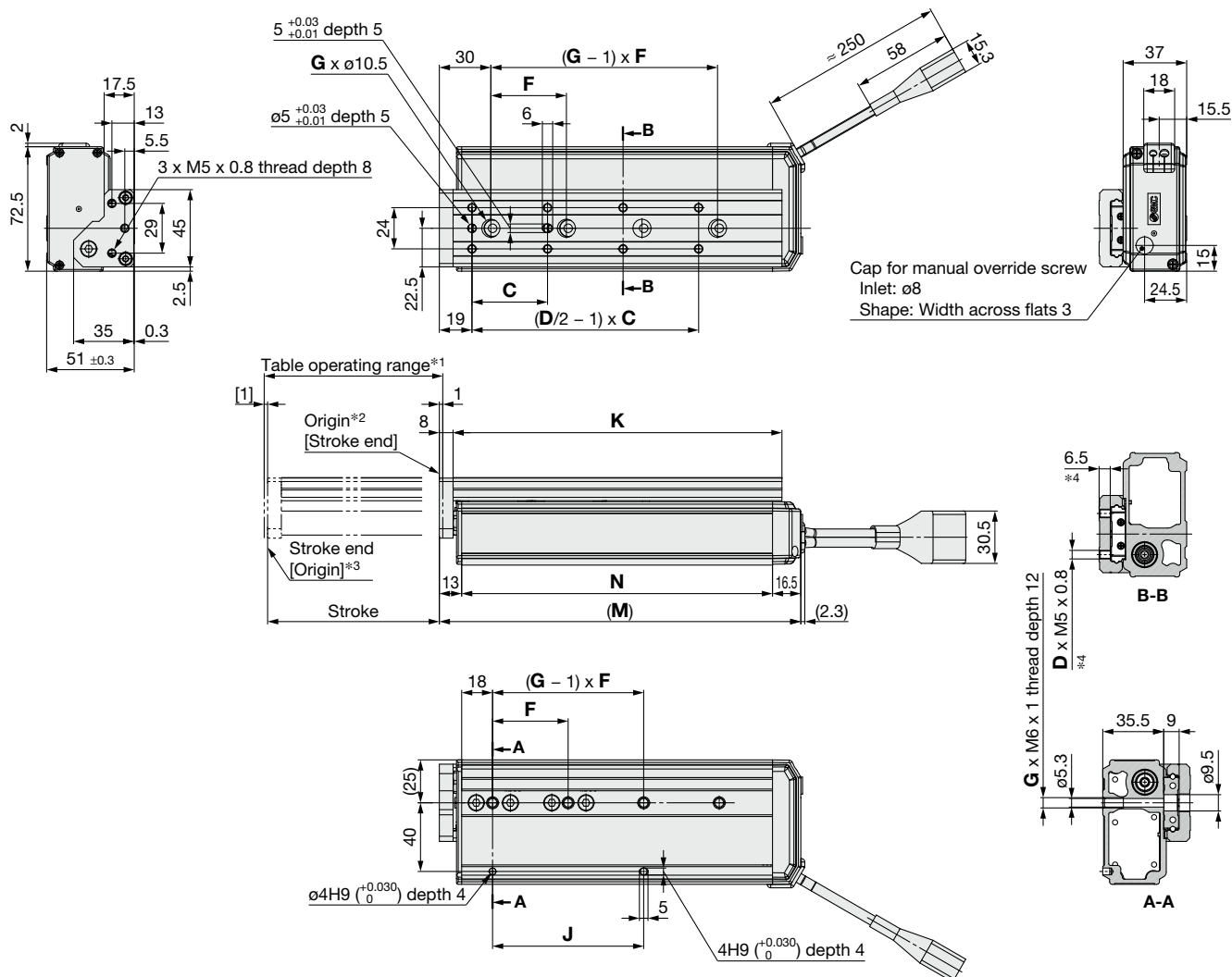

Model	C	D	F	G	J	K	M	N
LE2SH16RH□-50A□	40	6	45	2	45	116.5	135.5	106
LE2SH16RH□-100□□	44	8	44	4	88	191.5	210.5	181

*1 This is the range within which the table can move when it returns to origin.
Make sure that workpieces mounted on the table do not interfere with other workpieces or the facilities around the table.

*2 Position after returning to origin

*3 [] for when the direction of return to origin has changed

*4 If the workpiece retaining screws are too long, they may come in contact with the guide block, resulting in a malfunction.
Use screws of a length equal to or shorter than the thread length.

Model Selection

LE2FS□H

LE2FB□H

LE2Y□H

LE2YG□H

LE2S(H)□H

LE2R□H

Auto Switch

Dimensions: Basic Type/R Type

LE2SH25RH

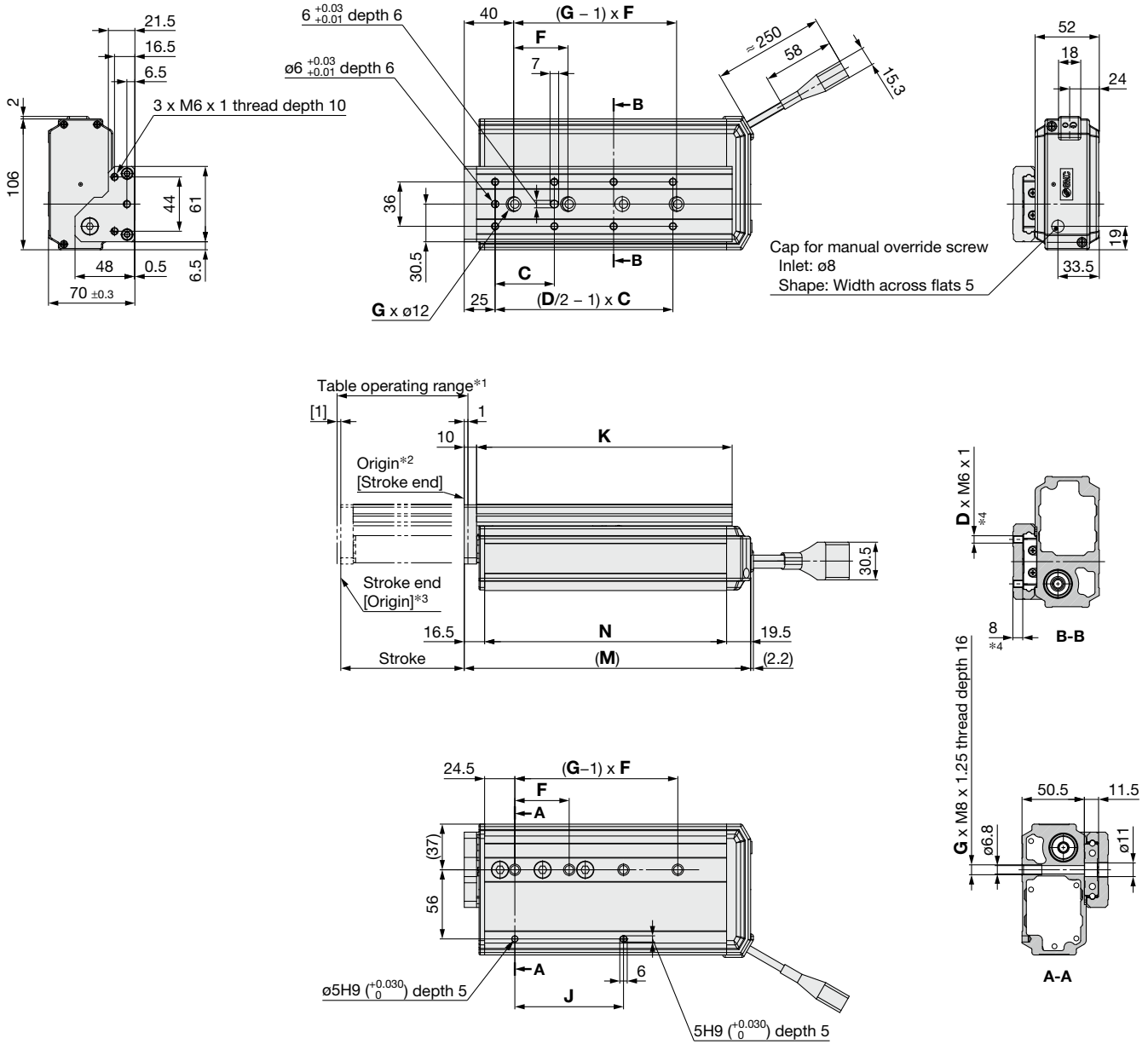

Model	C	D	F	G	J	K	M	N
LE2SH25RH□-50□□	75	4	80	2	80	143	168	132
LE2SH25RH□-100□□	48	8	44	4	88	207	232	196
LE2SH25RH□-150□□	65	8	66	4	132	285	310	274

*1 This is the range within which the table can move when it returns to origin. Make sure that workpieces mounted on the table do not interfere with other workpieces or the facilities around the table.
 *2 Position after returning to origin
 *3 [] for when the direction of return to origin has changed
 *4 If the workpiece retaining screws are too long, they may come in contact with the guide block, resulting in a malfunction. Use screws of a length equal to or shorter than the thread length.

Dimensions: Symmetrical Type/L Type

LE2SH16LH

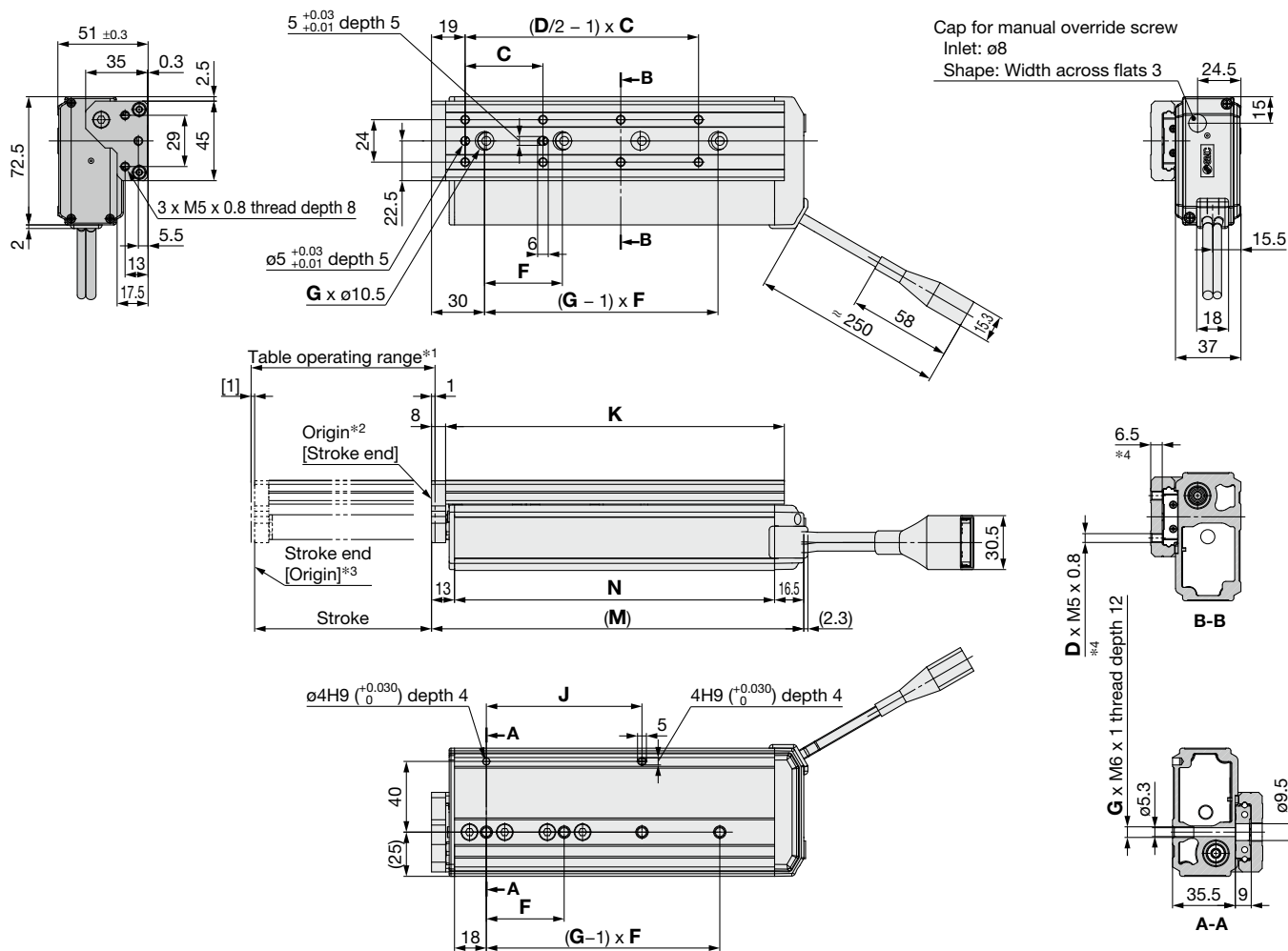

- Model Selection
- LE2FS□H
- LE2FB□H
- LE2Y□H
- LE2YG□H
- LE2S(H)□H
- LE2R□H
- Auto Switch

Model	C	D	F	G	J	K	M	N
LE2SH16LH□-50A□	40	6	45	2	45	116.5	135.5	106
LE2SH16LH□-100□	44	8	44	4	88	191.5	210.5	181

*1 This is the range within which the table can move when it returns to origin. Make sure that workpieces mounted on the table do not interfere with other workpieces or the facilities around the table.
 *2 Position after returning to origin
 *3 [] for when the direction of return to origin has changed
 *4 If the workpiece retaining screws are too long, they may come in contact with the guide block, resulting in a malfunction. Use screws of a length equal to or shorter than the thread length.

Dimensions: Symmetrical Type/L Type

LE2SH25LH

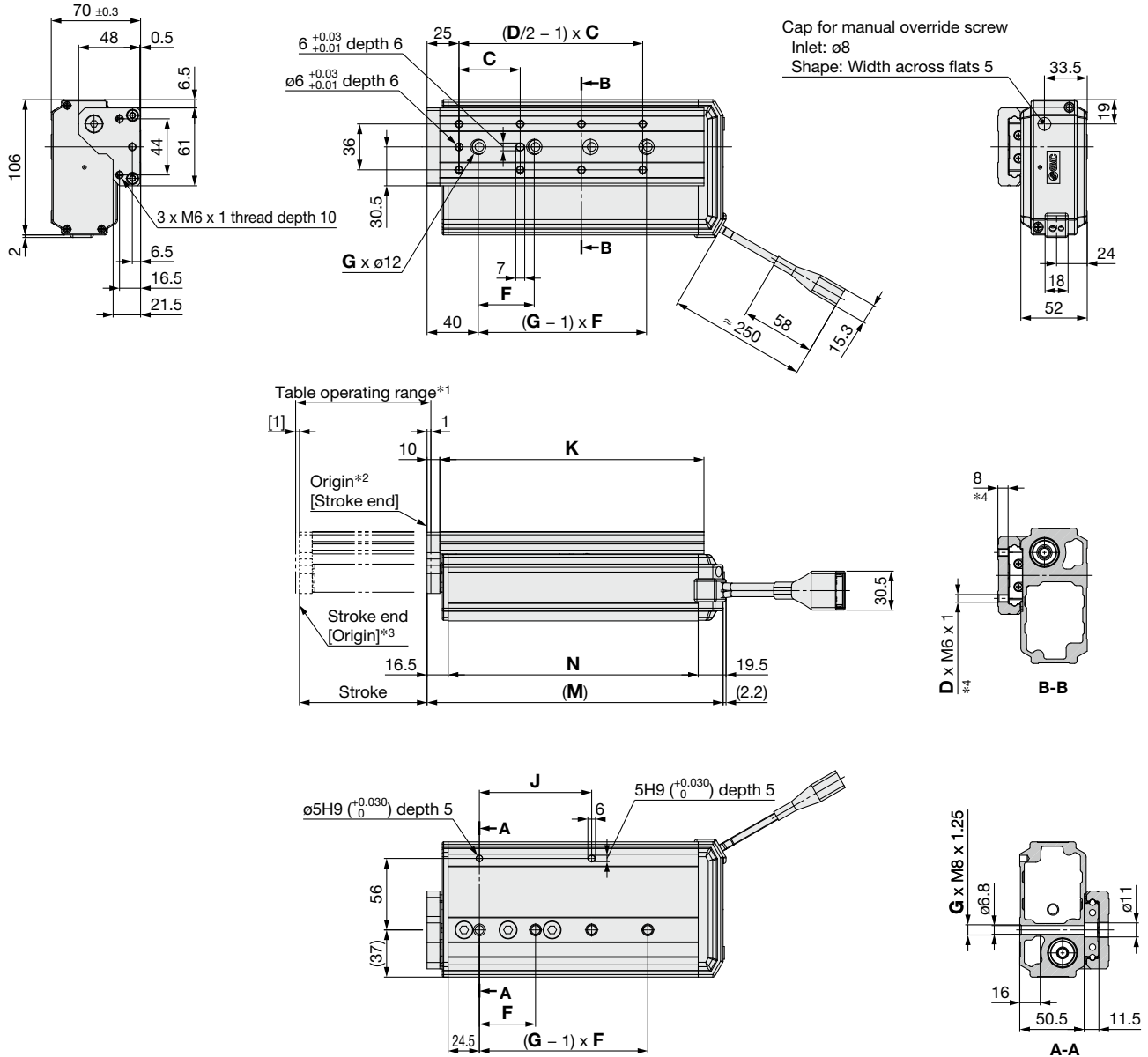

Model	C	D	F	G	J	K	M	N
LE2SH25LH□-50□□	75	4	80	2	80	143	168	132
LE2SH25LH□-100□□	48	8	44	4	88	207	232	196
LE2SH25LH□-150□□	65	8	66	4	132	285	310	274

- *1 This is the range within which the table can move when it returns to origin.
Make sure that workpieces mounted on the table do not interfere with other workpieces or the facilities around the table.
- *2 Position after returning to origin
- *3 [] for when the direction of return to origin has changed
- *4 If the workpiece retaining screws are too long, they may come in contact with the guide block, resulting in a malfunction.
Use screws of a length equal to or shorter than the thread length.

Dimensions: In-line Motor Type/D Type

LE2SH16DH

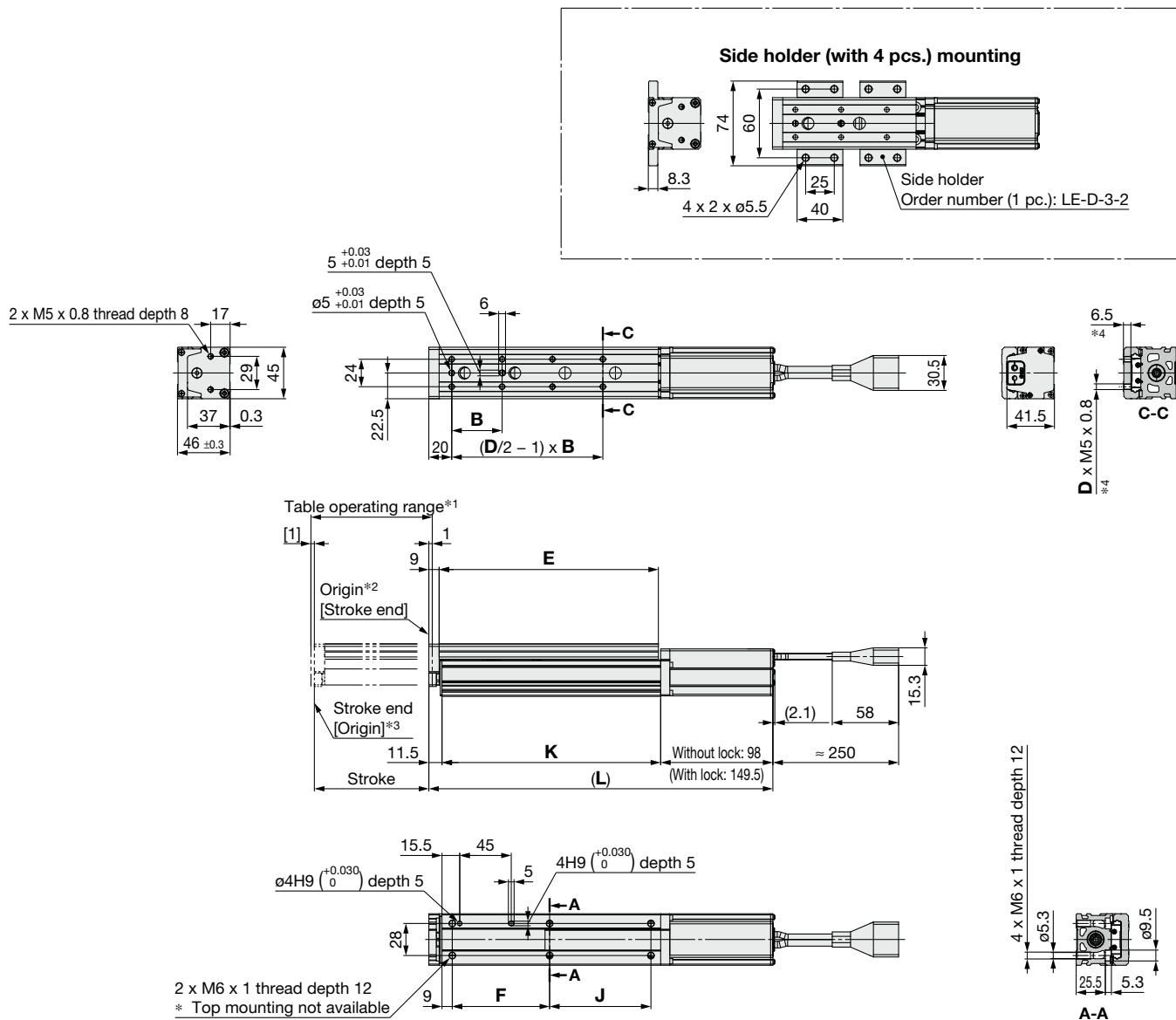

[mm]

Model	L	B	D	E	F	J	K
LE2SH16DH□-50A□□	231.5	40	6	116.5	65	39.5	122
LE2SH16DH□-50B□□	283						
LE2SH16DH□-100A□□	300.5	44	8	191.5	85	88.5	191
LE2SH16DH□-100B□□	352						

*1 This is the range within which the table can move when it returns to origin. Make sure that workpieces mounted on the table do not interfere with other workpieces or the facilities around the table.
 *2 Position after returning to origin
 *3 [] for when the direction of return to origin has changed
 *4 If the workpiece retaining screws are too long, they may come in contact with the guide block, resulting in a malfunction. Use screws of a length equal to or shorter than the thread length.

Model Selection

LE2FS□H

LE2FB□H

LE2Y□H

LE2YG□H

LE2S(H)□H

LE2R□H

Auto Switch

Dimensions: In-line Motor Type/D Type

LE2SH25DH

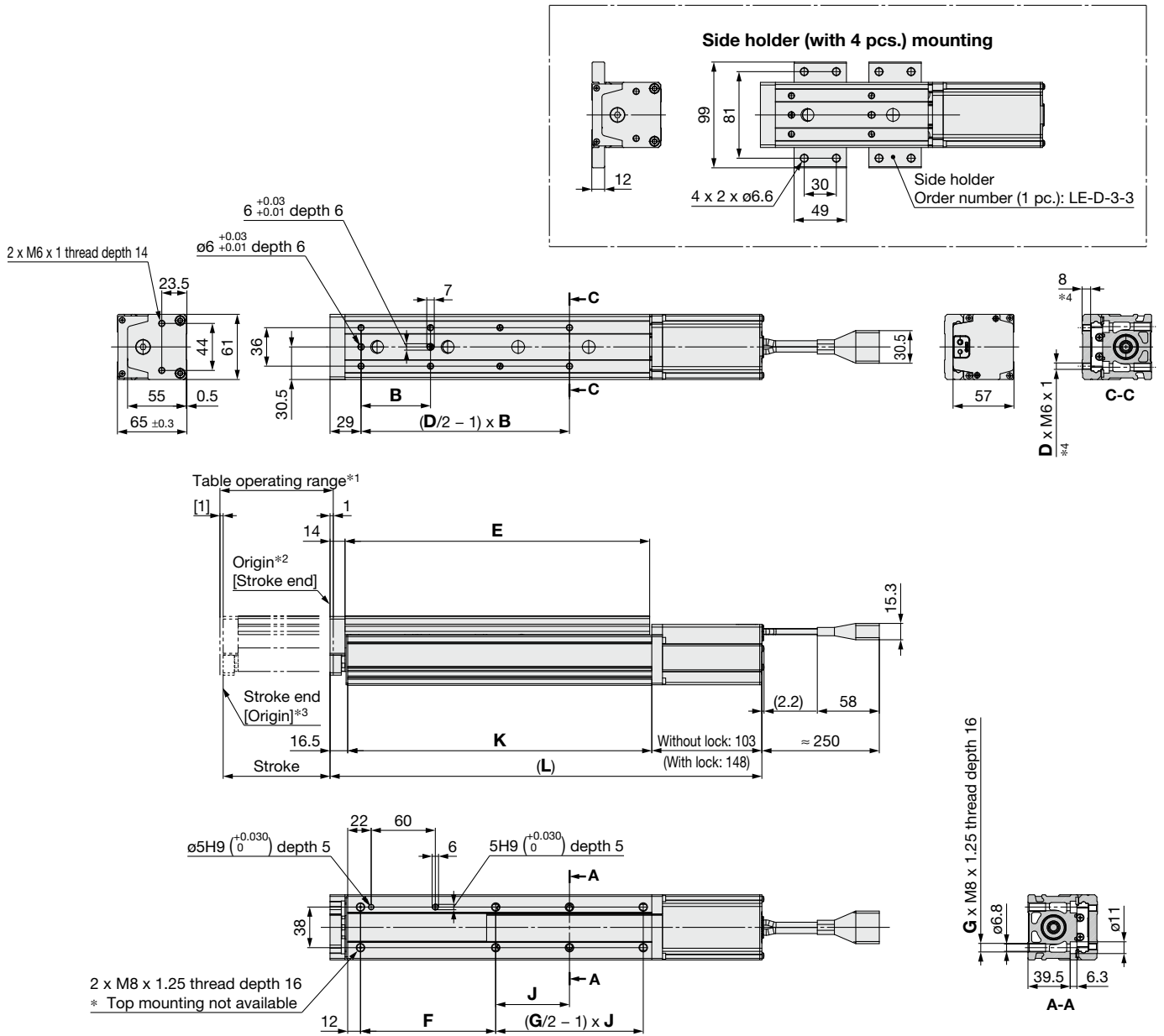

[mm]

Model	L	B	D	E	F	G	J	K
LE2SH25DH□-50A□□	264	75	4	143	84		40.5	144.5
LE2SH25DH□-50B□□	309							
LE2SH25DH□-100A□□	326	48	8	207	98.5		88	206.5
LE2SH25DH□-100B□□	371							
LE2SH25DH□-150A□□	404	65		285	126.5	6	69	284.5
LE2SH25DH□-150B□□	449							

- *1 This is the range within which the table can move when it returns to origin.
Make sure that workpieces mounted on the table do not interfere with other workpieces or the facilities around the table.
- *2 Position after returning to origin
- *3 [] for when the direction of return to origin has changed
- *4 If the workpiece retaining screws are too long, they may come in contact with the guide block, resulting in a malfunction.
Use screws of a length equal to or shorter than the thread length.

Side Holder (For In-line Motor Type/D Type)

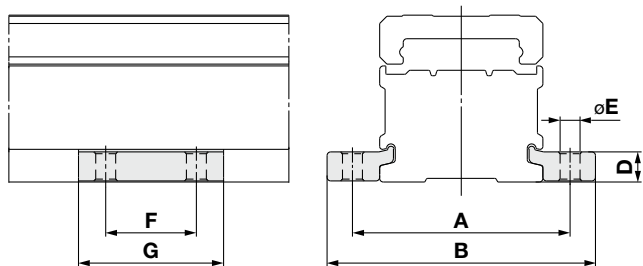

Part no.*1	A	B	D	E	F	G	Applicable model
LE-D-3-2	60	74	8.3	5.5	25	40	LE2SH16DH
LE-D-3-3	81	99	12	6.6	30	49	LE2SH25DH

[mm]

*1 Part numbers for 1 side holder

- Model Selection
- LE2FS□H
- LE2FB□H
- LE2Y□H
- LE2YG□H
- LE2S(H)□H
- LE2R□H
- Auto Switch

Rotary Table

LE2R□H Series

p. 123

Battery-less Absolute (Step Motor 24 VDC)



Model Selection

LE2FS□H

LE2FB□H

LE2Y□H

LE2YG□H

LE2S(H)□H

LE2R□H

Auto Switch

Model Selection



Selection Procedure

Operating conditions

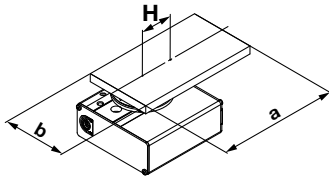

Electric rotary table: LE2RB502HJ
 Mounting position: Horizontal
 Load type: Inertial load T_a
 Configuration of load: 150 mm x 80 mm (Rectangular plate)
 Rotation angle θ : 180°

Angular acceleration/
 angular deceleration $\dot{\omega}$: 1000°/s²
 Angular speed ω : 420°/s
 Load mass m : 6.0 kg
 Distance between shaft and center of gravity H : 40 mm

Step 1 Moment of inertia—Angular acceleration/deceleration

① Calculation of moment of inertia

Formula

$$I = m \times (a^2 + b^2)/12 + m \times H^2$$

② **Moment of inertia—Check the angular acceleration/deceleration**
 Select a model based on the moment of inertia and angular acceleration and deceleration while referencing the (Moment of Inertia—Angular Acceleration/Deceleration graph).

Selection example

$$I = 6.0 \times (0.15^2 + 0.08^2)/12 + 6.0 \times 0.04^2 = 0.0241 \text{ kg}\cdot\text{m}^2$$

LE2R50

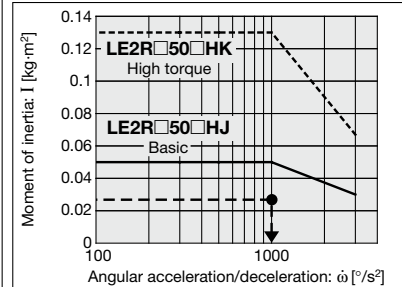

Step 2 Necessary torque

① Load type

- Static load: T_s
- Resistance load: T_f
- Inertial load: T_a

Formula

$$\begin{aligned} \text{Effective torque} &\geq T_s \\ \text{Effective torque} &\geq T_f \times 1.5 \\ \text{Effective torque} &\geq T_a \times 1.5 \end{aligned}$$

② Check the effective torque

Confirm whether it is possible to control the speed based on the effective torque corresponding with the angular speed while referencing the (Effective Torque—Angular Speed graph).

Selection example

$$\begin{aligned} \text{Inertial load: } T_a \\ T_a \times 1.5 &= I \times \dot{\omega} \times 2 \pi / 360 \times 1.5 \\ &= 0.0241 \times 1000 \times 0.0175 \times 1.5 \\ &= 0.63 \text{ N}\cdot\text{m} \end{aligned}$$

LE2R50

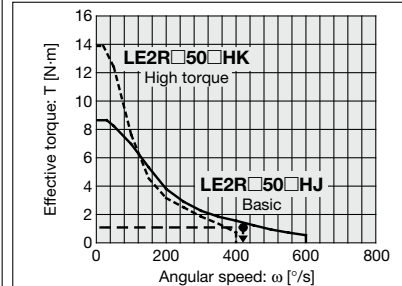

Step 3 Allowable load

① Check the allowable load

- Radial load
- Thrust load
- Moment

Formula

$$\begin{aligned} \text{Allowable thrust load} &\geq m \times 9.8 \\ \text{Allowable moment} &\geq m \times 9.8 \times H \end{aligned}$$

Selection example

- Thrust load
 $6.0 \times 9.8 = 58.8 \text{ N} < \text{Allowable load OK}$
- Allowable moment
 $6.0 \times 9.8 \times 0.04 = 2.352 \text{ N}\cdot\text{m} < \text{Allowable moment OK}$

Step 4 Rotation time

① Calculation of cycle time (rotation time)

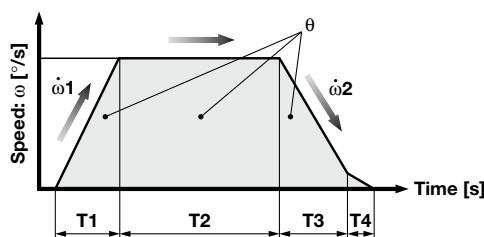

- θ : Rotation angle [°]
- ω : Angular speed [°/s]
- $\dot{\omega}1$: Angular acceleration [°/s²]
- $\dot{\omega}2$: Angular deceleration [°/s²]
- T1: Acceleration time [s]... Time until reaching the set speed
- T2: Constant speed time [s]... Time while the actuator is operating at a constant speed
- T3: Deceleration time [s]... Time from the beginning of the constant speed operation to stop
- T4: Settling time [s] ... Time until positioning is completed

Formula

$$\begin{aligned} \text{Angular acceleration time } T1 &= \omega / \dot{\omega}1 \\ \text{Angular deceleration time } T3 &= \omega / \dot{\omega}2 \\ \text{Constant speed time } T2 &= \{\theta - 0.5 \times \omega \times (T1 + T3)\} / \omega \\ \text{Settling time } T4 &= 0.2 \text{ [s]} \\ \text{Cycle time } T &= T1 + T2 + T3 + T4 \end{aligned}$$

Selection example

- Angular acceleration time $T1 = 420/1000 = 0.42 \text{ s}$
- Angular deceleration time $T3 = 420/1000 = 0.42 \text{ s}$
- Constant speed time
 $T2 = \{180 - 0.5 \times 420 \times (0.42 + 0.42)\} / 420 = 0.009 \text{ s}$
- Cycle time
 $T = T1 + T2 + T3 + T4 = 0.42 + 0.009 + 0.42 + 0.2 = 1.049 \text{ [s]}$

Formulas for Moment of Inertia (Calculation of moment of inertia I)

I: Moment of inertia [kg·m²] m: Load mass [kg]

1. Thin bar

Position of rotation shaft: Perpendicular to a bar through one end

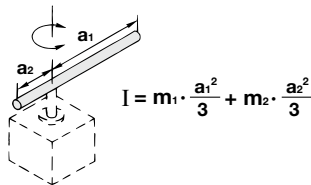

2. Thin bar

Position of rotation shaft: Passes through the center of gravity of the bar.

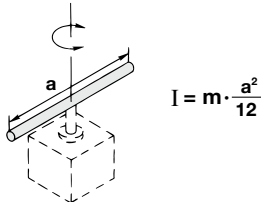

3. Thin rectangular plate (cuboid)

Position of rotation shaft: Passes through the center of gravity of a plate.

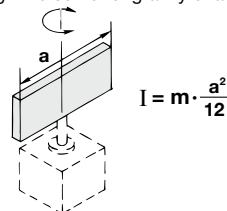

4. Thin rectangular plate (cuboid)

Position of rotation shaft: Perpendicular to the plate and passes through one end. (The same applies to thicker cuboids.)

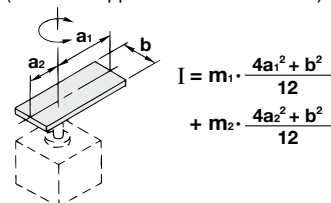

5. Thin rectangular plate (cuboid)

Position of the rotation shaft: Passes through the center of gravity of the plate and perpendicular to the plate. (The same applies to thicker cuboids.)

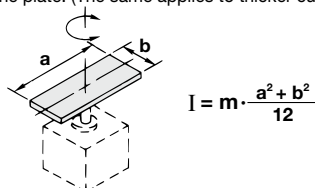

6. Cylindrical shape (including a thin disk)

Position of rotation shaft: Center axis

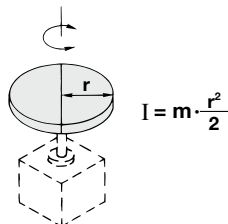

7. Sphere

Position of rotation shaft: Diameter

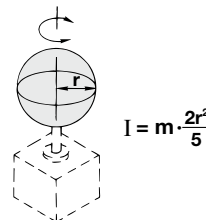

8. Thin disk (mounted vertically)

Position of rotation shaft: Diameter

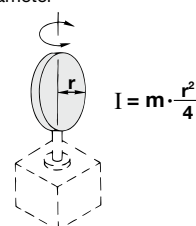

9. When a load is mounted on the end of the lever

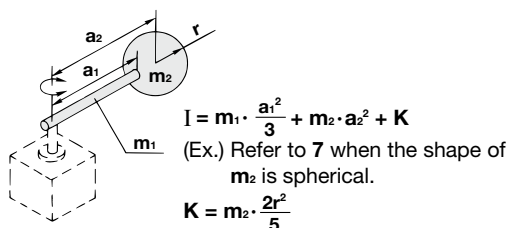

10. Gear transmission

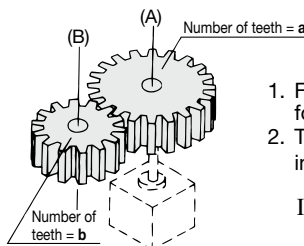

1. Find the moment of inertia I_B for the rotation of shaft (B).
2. Then, replace the moment of inertia I_B around the shaft (A) by I_A ,

$$I_A = \left(\frac{a}{b}\right)^2 \cdot I_B$$

Load Type

Load type				
Static load: Ts	Resistance load: Tf		Inertial load: Ta	
Only pressing force is necessary. (e.g. for clamping)	Gravity or friction force is applied to rotating direction.		Rotate the load with inertia.	
	Gravity is applied. 	Friction force is applied. 	Center of rotation and center of gravity of the load are concentric. 	Rotation shaft is vertical (up and down).
Ts = F · L Ts: Static load [N·m] F: Clamping force [N] L: Distance from the rotation center to the clamping position [m]	Gravity is applied to rotating direction. Tf = m · g · L Tf: Resistance load [N·m] m: Load mass [kg] g: Gravitational acceleration 9.8 [m/s ²] L: Distance from the rotation center to the point of application of the gravity or friction force [m] μ: Friction coefficient	Friction force is applied to rotating direction. Tf = μ · m · g · L	Ta = I · ω̇ · 2π/360 (Ta = I · ω̇ · 0.0175) Ta: Inertial load [N·m] I: Moment of inertia [kg·m ²] ω̇: Angular acceleration/deceleration [°/s ²] ω: Angular speed [°/s]	
Necessary torque: T = Ts	Necessary torque: T = Tf x 1.5*1		Necessary torque: T = Ta x 1.5*1	
<ul style="list-style-type: none"> • Resistance load: Gravity or friction force is applied to rotating direction. Ex. 1) Rotation shaft is horizontal (lateral), and the rotation center and the center of gravity of the load are not concentric. Ex. 2) Load moves by sliding on the floor. * The total of resistance load and inertial load is the necessary torque. T = (Tf + Ta) x 1.5 	<ul style="list-style-type: none"> • Not resistance load: Neither gravity or friction force is applied to rotating direction. Ex. 1) Rotation shaft is vertical (up and down). Ex. 2) Rotation shaft is horizontal (lateral), and rotation center and the center of gravity of the load are concentric. * Necessary torque is inertial load only. T = Ta x 1.5 			

*1 To adjust the speed, margin is necessary for Tf and Ta.

Model Selection
 LE2FS□H
 LE2FB□H
 LE2Y□H
 LE2YG□H
 LE2S(H)□H
 LE2R□H
 Auto Switch

Moment of Inertia—Angular Acceleration/Deceleration (Guide)

LE2R30

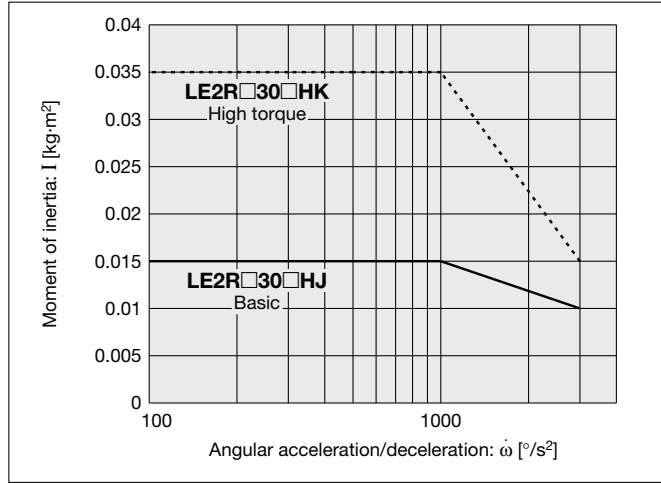

Effective Torque—Angular Speed (Guide)

LE2R30

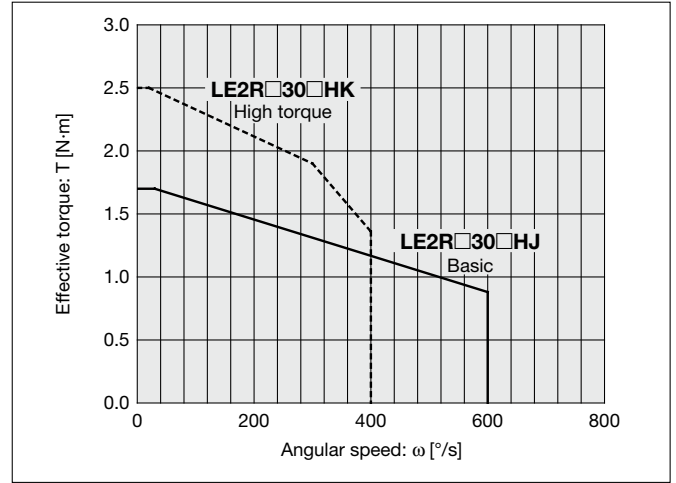

LE2R50

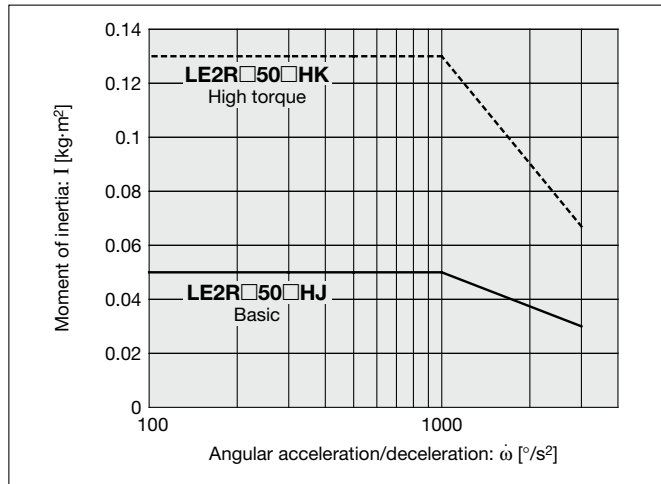

LE2R50

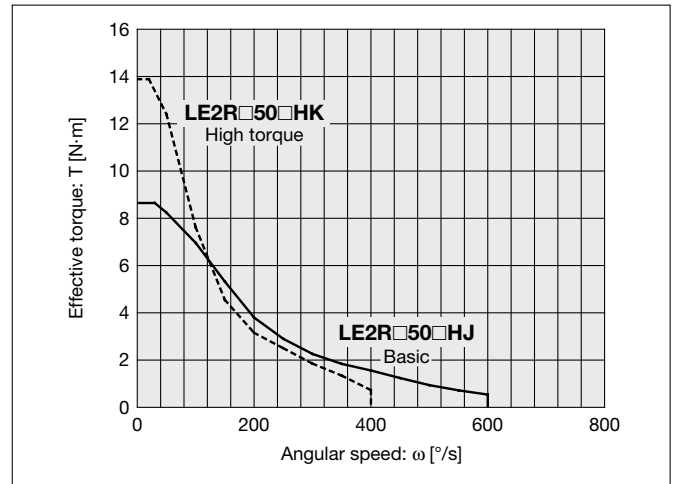

Allowable Load

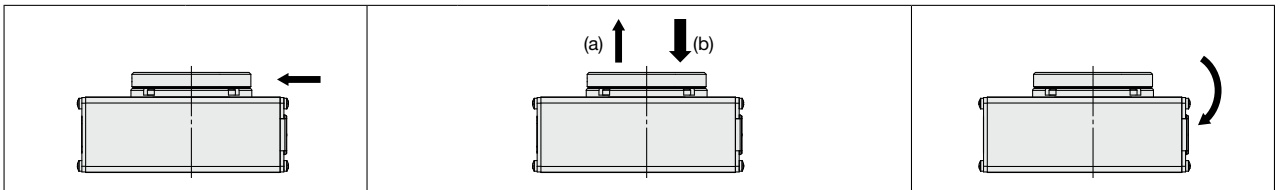

Size	Allowable radial load [N]		Allowable thrust load [N]				Allowable moment [N-m]	
	Basic type	High-precision type	(a)		(b)		Basic type	High-precision type
			Basic type	High-precision type	Basic type	High-precision type		
30	196	233	197		363	398	5.3	6.4
50	314	378	296		398	517	9.7	12.0

Table Displacement (Reference Value)

- Displacement at point A when a load is applied to point A 100 mm away from the rotation center.

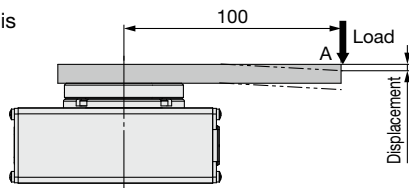

LE2R□30

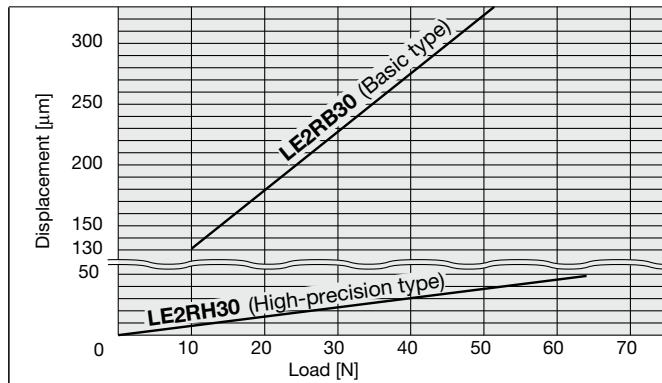

LE2R□50

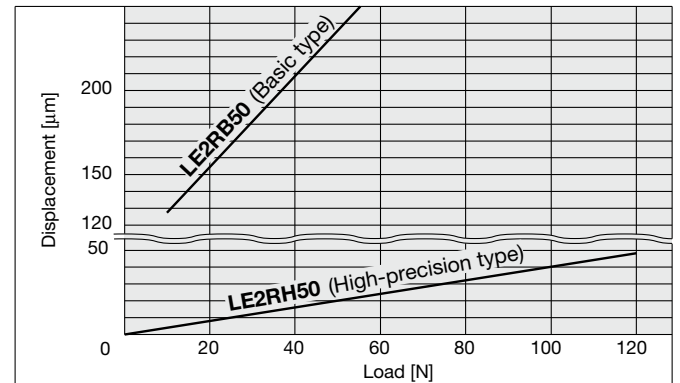

Deflection Accuracy: Displacement at 180° Rotation (Guide)

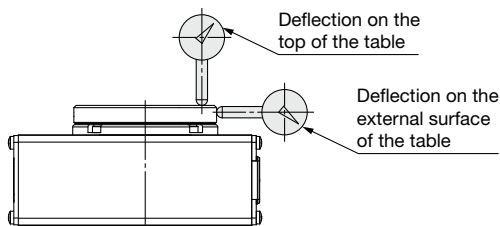

Measured part	LE2RB (Basic type)	LE2RH (High-precision type)
Deflection on the top of the table	0.1	0.03
Deflection on the external surface of the table	0.1	0.03

[mm]

Model Selection

LE2FS□H

LE2FB□H

LE2Y□H

LE2YG□H

LE2S(H)□H

LE2R□H

Auto Switch

Compatible with Manifold Controller

Rotary Table

LE2R□H Series LE2R30, 50



How to Order

LE2R **H** **30** **2** **H** **K** - **2**

① ② ③ ④ ⑤ ⑥

① Table accuracy

B	Basic type
H	High-precision type

② Size

30
50

③ Motor cable entry direction

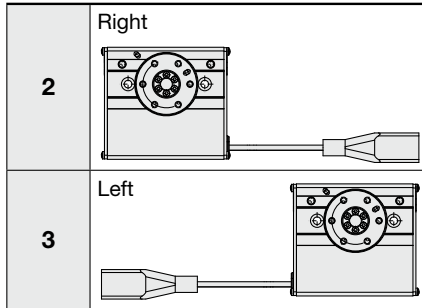

④ Motor type

Symbol	Type	Compatible controller
H	Battery-less absolute (Step motor 24 VDC)	JXD1

⑤ Max. rotating torque [N·m]

Symbol	Type	LE2R30	LE2R50
K	High torque	2.5	13.9
J	Basic	1.7	8.7

⑥ Rotation angle [°]

Symbol	LE2R30	LE2R50
2	External stopper: 180	
3	External stopper: 90	
4	320	

Specifications



- *1 Pushing force accuracy is LE2R30: ±25% (F.S.), LE2R50: ±20% (F.S.).
- *2 The angular acceleration, angular deceleration, and angular speed may fluctuate due to variations in the moment of inertia.
Refer to the "Moment of Inertia—Angular Acceleration/Deceleration, Effective Torque—Angular Speed" graphs on page 125 for confirmation.
- *3 The speed and force may change depending on the cable length, load, and mounting conditions. Furthermore, if the cable length exceeds 5 m, then it will decrease by up to 10% for each 5 m. (At 15 m: Reduced by up to 20%)
- *4 A reference value for correcting errors in reciprocal operation
- *5 Impact resistance: No malfunction occurred when the actuator was tested with a drop tester in both an axial direction and a perpendicular direction to the lead screw. (The test was performed with the actuator in the initial state.)
Vibration resistance: No malfunction occurred in a test ranging between 45 to 2000 Hz. The test was performed in both an axial direction and a perpendicular direction to the lead screw. (The test was performed with the actuator in the initial state.)
- *6 Indicates the max. power during operation (excluding the controller)
This value can be used for the selection of the power supply.

Model		LE2R□30K	LE2R□30J	LE2R□50K	LE2R□50J
Rotation angle [°]		320			
Lead [°]		8	12	7.5	12
Max. rotating torque [N·m]		2.5	1.7	13.9	8.7
Pushing torque	LE2R30: 40 to 60% [N·m] ^{*1 *3}	1.7 to 2.5	1.1 to 1.7	5.6 to 6.9	3.5 to 4.3
	LE2R50: 40 to 50% [N·m] ^{*1 *3}				
Max. moment of inertia [kg·m ²] ^{*2 *3}		0.035	0.015	0.13	0.05
Angular speed [°/s] ^{*2 *3}		20 to 400	30 to 600	20 to 400	30 to 600
Pushing speed [°/s]		20	30	20	30
Max. angular acceleration/deceleration [°/s ²] ^{*2}		3000			
Backlash [°]	Basic type	±0.2			
	High-precision type	±0.1			
Positioning repeatability [°]	Basic type	±0.05			
	High-precision type	±0.03			
Lost motion [°] ^{*4}	Basic type	0.3 or less			
	High-precision type	0.2 or less			
Impact/Vibration resistance [m/s ²] ^{*5}		150/30			
Actuation type		Special worm gear + Belt drive			
Max. operating frequency [c.p.m]		60			
Operating temperature range [°C]		5 to 40			
Operating humidity range [%RH]		90 or less (No condensation)			
Enclosure		IP20			
Weight [kg]	Basic type	1.1		2.1	
	High-precision type	1.2		2.3	
External stopper type	Rotation angle [°]	-2/ arm (1 pc.)	180		
		-3/ arm (2 pcs.)	90		
	Repeatability at the end [°]/ with external stopper	±0.01			
External stopper setting range [°]		±2			
Weight [kg]	-2/ arm (1 pc.)	Basic type	1.2	2.4	
		High-precision type	1.4	2.6	
	-3/ arm (2 pcs.)	Basic type	1.2	2.5	
	High-precision type	1.4	2.7		
Motor size		□28		□42	
Motor type		Battery-less absolute (Step motor 24 VDC)			
Encoder		Battery-less absolute			
Power supply voltage [V]		24 VDC ±10%			
Power [W] ^{*6}		Max. power 58		Max. power 52	

Model Selection

LE2FS□H

LE2FB□H

LE2Y□H

LE2YG□H

LE2S(H)□H

LE2R□H

Auto Switch

Table Rotation Angle Range

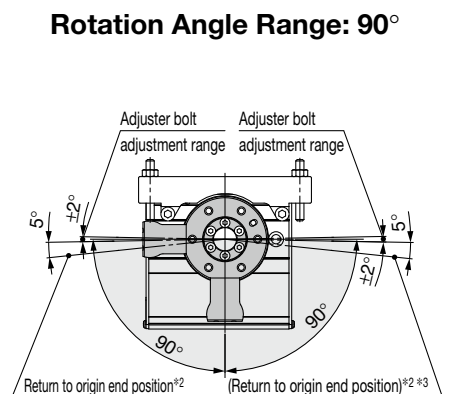
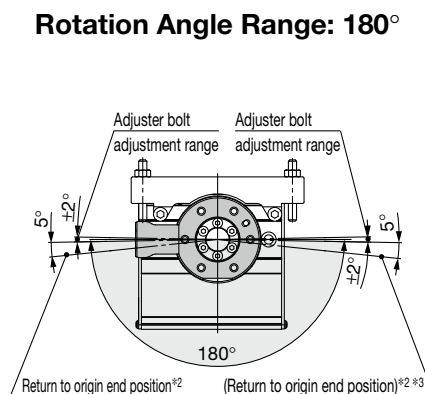
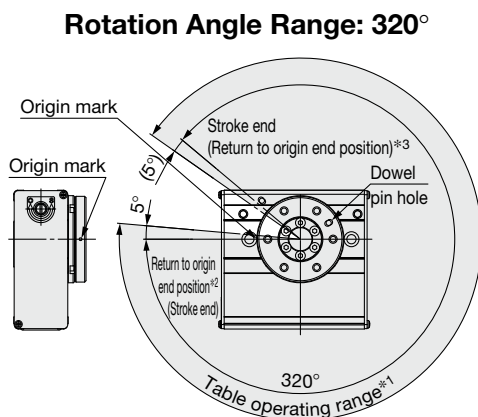

*1 This is the range within which the table can move when it returns to origin.

Make sure that workpieces mounted on the table do not interfere with other workpieces or the facilities around the table.

*2 Position after returning to origin. The position varies depending on whether there is an external stopper.

*3 [] for when the direction of return to origin has changed

* The figures show the origin position for each actuator.

Dimensions

LE2R□30□H□-4 (Rotation angle: 320°)

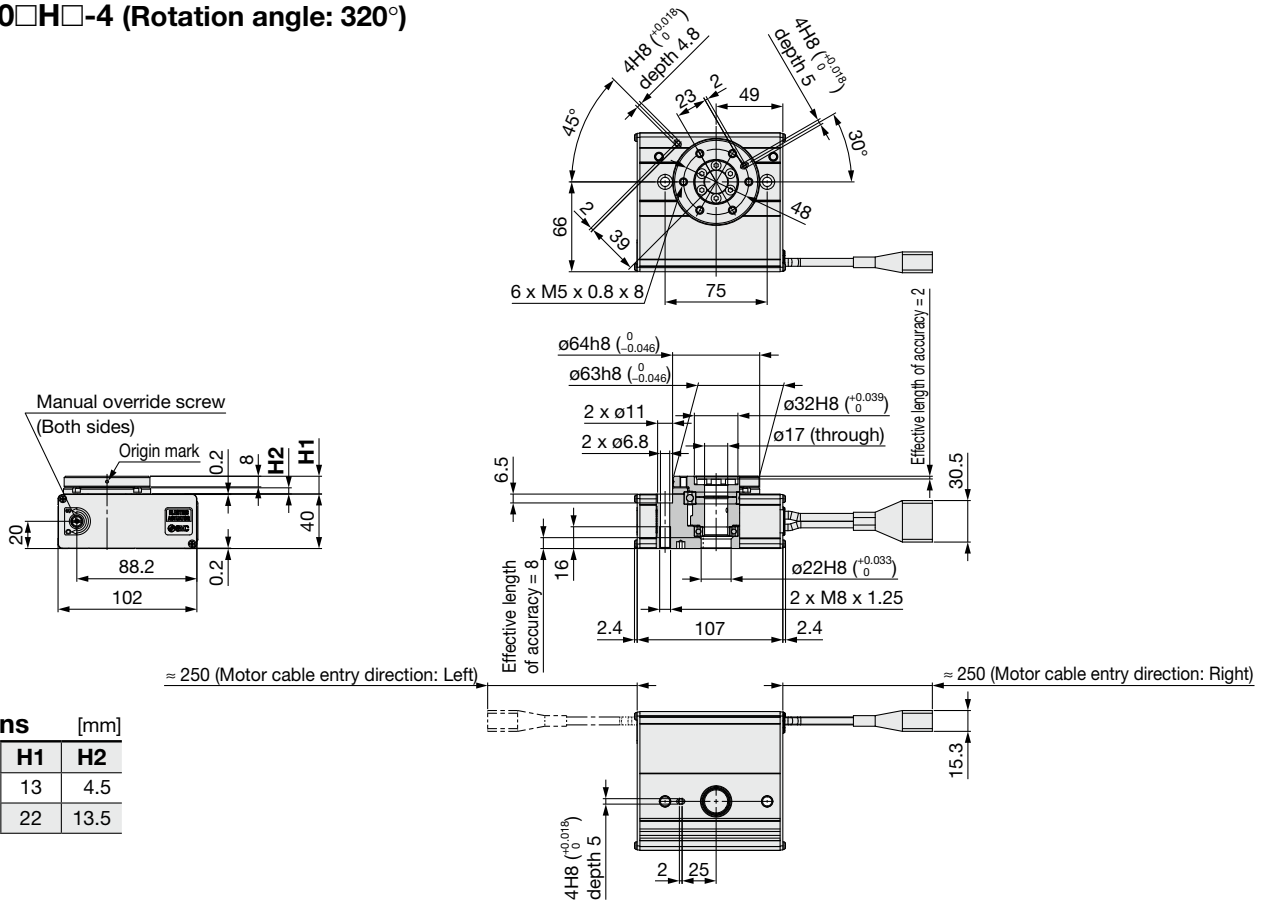

Dimensions [mm]

Model	H1	H2
LE2RB30	13	4.5
LE2RH30	22	13.5

LE2R□30□H□-2 (Rotation angle: 180°)

LE2R□30□H□-3 (Rotation angle: 90°)

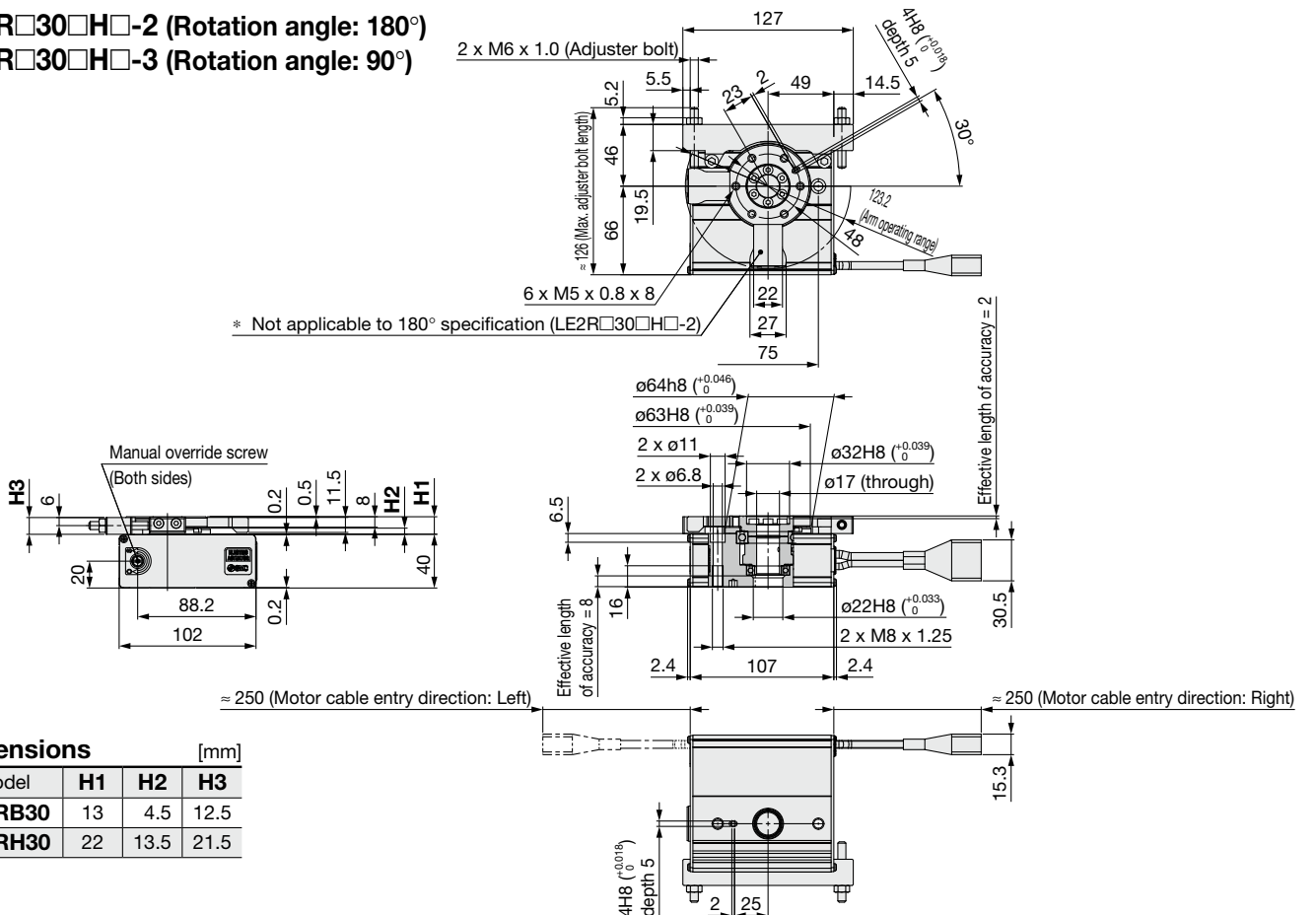

Dimensions [mm]

Model	H1	H2	H3
LE2RB30	13	4.5	12.5
LE2RH30	22	13.5	21.5

Dimensions

LE2R□50□H□-4 (Rotation angle: 320°)

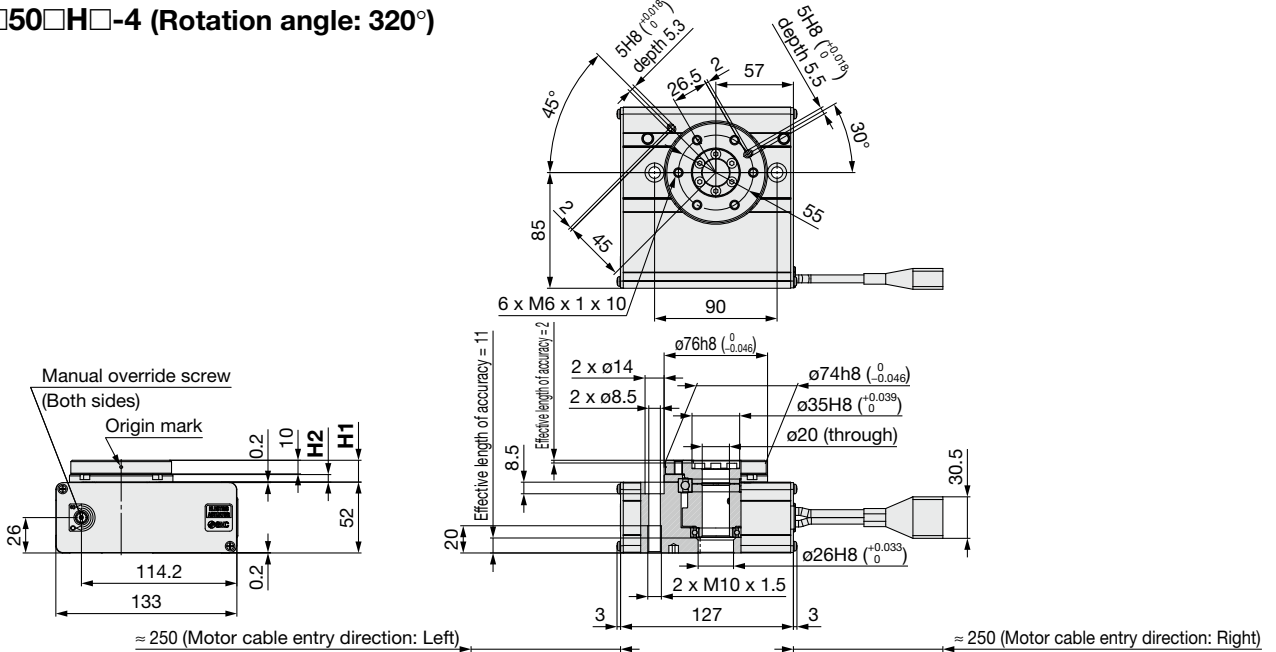

Model	H1	H2
LE2RB50	16	5.5
LE2RH50	26	15.5

LE2R□50□H□-2 (Rotation angle: 180°)
LE2R□50□H□-3 (Rotation angle: 90°)

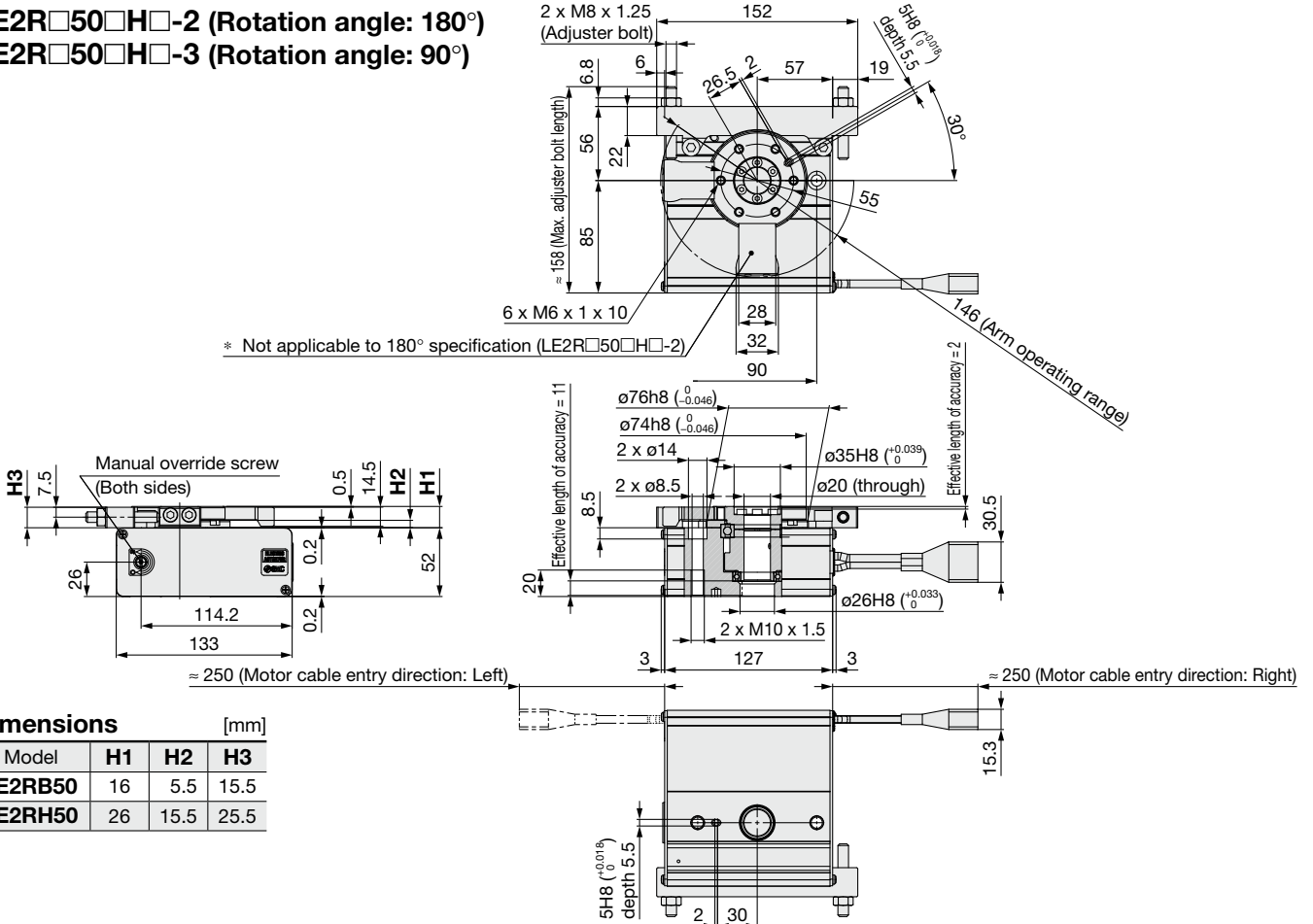

Model	H1	H2	H3
LE2RB50	16	5.5	15.5
LE2RH50	26	15.5	25.5

Model Selection

LE2FS□H

LE2FB□H

LE2Y□H

LE2YG□H

LE2S(H)□H

LE2R□H

Auto Switch

Solid State Auto Switch Direct Mounting Type D-M9N(V)/D-M9P(V)/D-M9B(V)



Refer to the SMC website for details on products that are compliant with international standards.

Auto Switch Specifications

PLC: Programmable Logic Controller

D-M9□, D-M9□V (With indicator light)						
Auto switch model	D-M9N	D-M9NV	D-M9P	D-M9PV	D-M9B	D-M9BV
Electrical entry direction	In-line	Perpendicular	In-line	Perpendicular	In-line	Perpendicular
Wiring type	3-wire				2-wire	
Output type	NPN		PNP		—	
Applicable load	IC circuit, Relay, PLC				24 VDC relay, PLC	
Power supply voltage	5, 12, 24 VDC (4.5 to 28 V)				—	
Current consumption	10 mA or less				—	
Load voltage	28 VDC or less		—		24 VDC (10 to 28 VDC)	
Load current	40 mA or less				2.5 to 40 mA	
Internal voltage drop	0.8 V or less at 10 mA (2 V or less at 40 mA)				4 V or less	
Leakage current	100 μA or less at 24 VDC				0.8 mA or less	
Indicator light	Red LED illuminates when turned ON.					
Standards	CE/UKCA marking					

Grommet

- 2-wire load current is reduced (2.5 to 40 mA).
- Using flexible cable as standard spec.



Oilproof Flexible Heavy-duty Lead Wire Specifications

Auto switch model		D-M9N(V)	D-M9P(V)	D-M9B(V)
Sheath	Outside diameter [mm]	ø2.6		
Insulator	Number of cores	3 cores (Brown/Blue/Black)		2 cores (Brown/Blue)
	Outside diameter [mm]	ø0.88		
Conductor	Effective area [mm ²]	0.15		
	Strand diameter [mm]	ø0.05		
Min. bending radius [mm] (Reference values)		17		

Caution

Precautions

Fix the auto switch with the existing screw installed on the auto switch body. The auto switch may be damaged if a screw other than the one supplied is used.

- * Refer to the **Web Catalog** for solid state auto switch common specifications.
- * Refer to the **Web Catalog** for lead wire lengths.

Weight

[g]

Auto switch model		D-M9N(V)	D-M9P(V)	D-M9B(V)
Lead wire length	0.5 m (Nil)	8	7	7
	1 m (M)	14	13	13
	3 m (L)	41	38	38
	5 m (Z)	68	63	63

Dimensions

[mm]

D-M9□

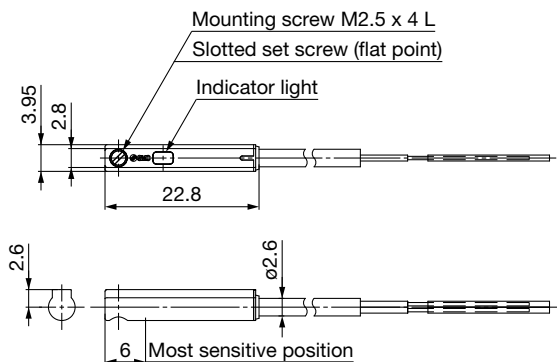

D-M9□V

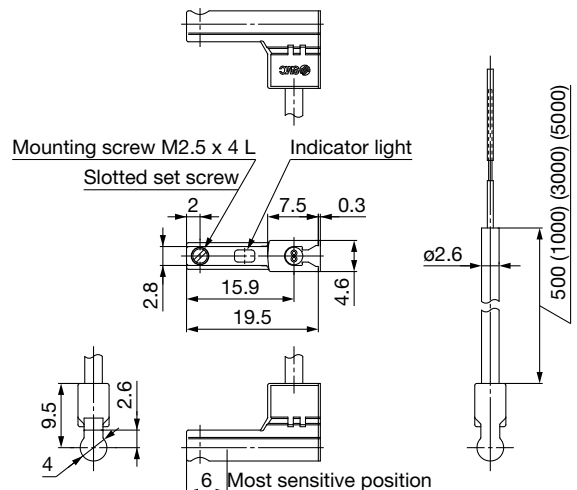

Normally Closed Solid State Auto Switch Direct Mounting Type D-M9NE(V)/D-M9PE(V)/D-M9BE(V)



Refer to the SMC website for details on products that are compliant with international standards.

Auto Switch Specifications

PLC: Programmable Logic Controller

D-M9□E, D-M9□EV (With indicator light)						
Auto switch model	D-M9NE	D-M9NEV	D-M9PE	D-M9PEV	D-M9BE	D-M9BEV
Electrical entry direction	In-line	Perpendicular	In-line	Perpendicular	In-line	Perpendicular
Wiring type	3-wire				2-wire	
Output type	NPN		PNP		—	
Applicable load	IC circuit, Relay, PLC				24 VDC relay, PLC	
Power supply voltage	5, 12, 24 VDC (4.5 to 28 V)					
Current consumption	10 mA or less				—	
Load voltage	28 VDC or less		—		24 VDC (10 to 28 VDC)	
Load current	40 mA or less				2.5 to 40 mA	
Internal voltage drop	0.8 V or less at 10 mA (2 V or less at 40 mA)				4 V or less	
Leakage current	100 μA or less at 24 VDC				0.8 mA or less	
Indicator light	Red LED illuminates when turned ON.					
Standards	CE/UKCA marking					

Oilproof Flexible Heavy-duty Lead Wire Specifications

Auto switch model		D-M9NE(V)	D-M9PE(V)	D-M9BE(V)
Sheath	Outside diameter [mm]	ø2.6		
Insulator	Number of cores	3 cores (Brown/Blue/Black)		2 cores (Brown/Blue)
	Outside diameter [mm]	ø0.88		
Conductor	Effective area [mm ²]	0.15		
	Strand diameter [mm]	ø0.05		
Min. bending radius [mm] (Reference values)		17		

* Refer to the **Web Catalog** for solid state auto switch common specifications.
* Refer to the **Web Catalog** for lead wire lengths.

Weight

[g]

Auto switch model		D-M9NE(V)	D-M9PE(V)	D-M9BE(V)
Lead wire length	0.5 m (Nil)	8	7	7
	1 m (M)*1	14	13	13
	3 m (L)	41	38	38
	5 m (Z)*1	68	63	63

*1 The 1 m and 5 m options are produced upon receipt of order.

Grommet

- Output signal turns on when no magnetic force is detected.
- Can be used for the actuator adopted by the solid state auto switch D-M9 series (excluding special order products)



Caution

Precautions

Fix the auto switch with the existing screw installed on the auto switch body. The auto switch may be damaged if a screw other than the one supplied is used.

Dimensions

[mm]

D-M9□E

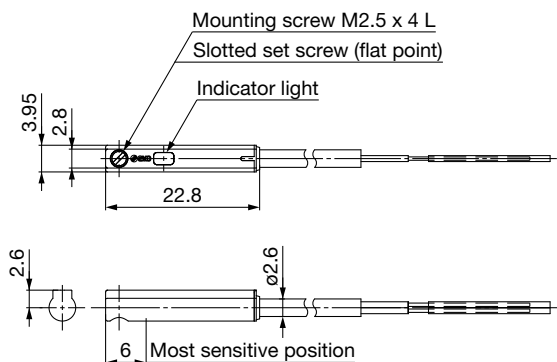

D-M9□EV

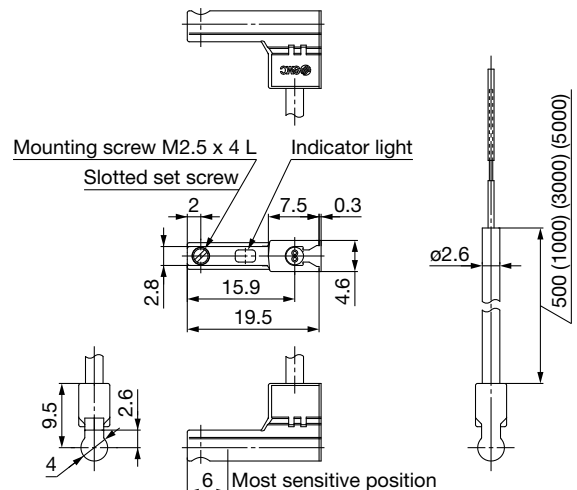

2-Color Indicator Solid State Auto Switch Direct Mounting Type D-M9NW(V)/D-M9PW(V)/D-M9BW(V)

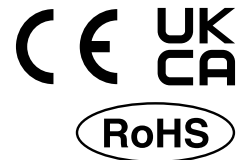

Refer to the SMC website for details on products that are compliant with international standards.

Auto Switch Specifications

PLC: Programmable Logic Controller

D-M9□W, D-M9□WV (With indicator light)						
Auto switch model	D-M9NW	D-M9NWV	D-M9PW	D-M9PWV	D-M9BW	D-M9BWV
Electrical entry direction	In-line	Perpendicular	In-line	Perpendicular	In-line	Perpendicular
Wiring type	3-wire				2-wire	
Output type	NPN		PNP		—	
Applicable load	IC circuit, Relay, PLC				24 VDC relay, PLC	
Power supply voltage	5, 12, 24 VDC (4.5 to 28 V)				—	
Current consumption	10 mA or less				—	
Load voltage	28 VDC or less		—		24 VDC (10 to 28 VDC)	
Load current	40 mA or less				2.5 to 40 mA	
Internal voltage drop	0.8 V or less at 10 mA (2 V or less at 40 mA)				4 V or less	
Leakage current	100 μA or less at 24 VDC				0.8 mA or less	
Indicator light	Operating range Red LED illuminates. Proper operating range Green LED illuminates.					
Standards	CE/UKCA marking					

Grommet

- 2-wire load current is reduced (2.5 to 40 mA).
- Using flexible cable as standard spec.
- The proper operating range can be determined by the color of the light. (Red → Green ← Red)



Caution

Precautions

Fix the auto switch with the existing screw installed on the auto switch body. The auto switch may be damaged if a screw other than the one supplied is used.

Oilproof Flexible Heavy-duty Lead Wire Specifications

Auto switch model		D-M9NW(V)	D-M9PW(V)	D-M9BW(V)
Sheath	Outside diameter [mm]	ø2.6		
Insulator	Number of cores	3 cores (Brown/Blue/Black)		2 cores (Brown/Blue)
	Outside diameter [mm]	ø0.88		
Conductor	Effective area [mm ²]	0.15		
	Strand diameter [mm]	ø0.05		
Min. bending radius [mm] (Reference values)		17		

- * Refer to the **Web Catalog** for solid state auto switch common specifications.
- * Refer to the **Web Catalog** for lead wire lengths.

Weight

[g]

Auto switch model		D-M9NW(V)	D-M9PW(V)	D-M9BW(V)
Lead wire length	0.5 m (Nil)	8	7	7
	1 m (M)	14	13	13
	3 m (L)	41	38	38
	5 m (Z)	68	63	63

Dimensions

[mm]

D-M9□W

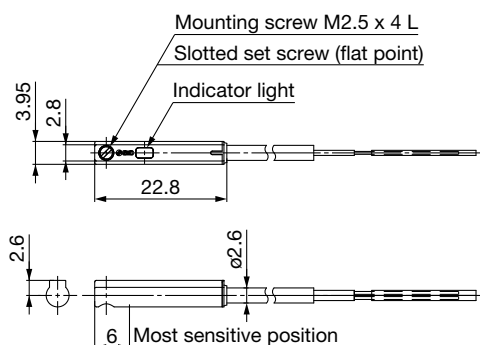

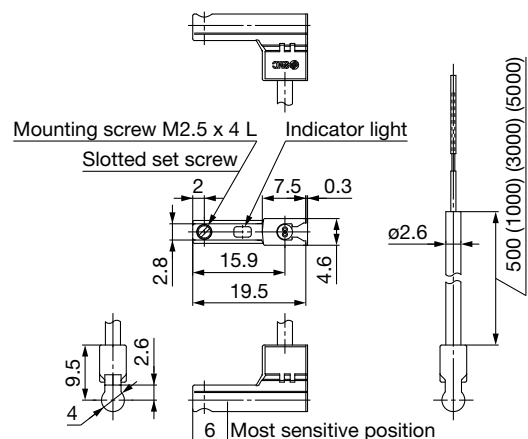

D-M9□WV



Safety Instructions

These safety instructions are intended to prevent hazardous situations and/or equipment damage. These instructions indicate the level of potential hazard with the labels of “**Caution**,” “**Warning**” or “**Danger**.” They are all important notes for safety and must be followed in addition to International Standards (ISO/IEC)*1), and other safety regulations.

 **Danger :** **Danger** indicates a hazard with a high level of risk which, if not avoided, will result in death or serious injury.

 **Warning:** **Warning** indicates a hazard with a medium level of risk which, if not avoided, could result in death or serious injury.

 **Caution:** **Caution** indicates a hazard with a low level of risk which, if not avoided, could result in minor or moderate injury.

*1) ISO 4414: Pneumatic fluid power - General rules and safety requirements for systems and their components
ISO 4413: Hydraulic fluid power - General rules and safety requirements for systems and their components
IEC 60204-1: Safety of machinery - Electrical equipment of machines - Part 1: General requirements
ISO 10218-1: Robots and robotic devices - Safety requirements for industrial robots - Part 1: Robots etc.

Warning

1. The compatibility of the product is the responsibility of the person who designs the equipment or decides its specifications.

Since the product specified here is used under various operating conditions, its compatibility with specific equipment must be decided by the person who designs the equipment or decides its specifications based on necessary analysis and test results. The expected performance and safety assurance of the equipment will be the responsibility of the person who has determined its compatibility with the product. This person should also continuously review all specifications of the product referring to its latest catalog information, with a view to giving due consideration to any possibility of equipment failure when configuring the equipment.

2. Only personnel with appropriate training should operate machinery and equipment.

The product specified here may become unsafe if handled incorrectly. The assembly, operation and maintenance of machines or equipment including our products must be performed by an operator who is appropriately trained and experienced.

3. Do not service or attempt to remove product and machinery/equipment until safety is confirmed.

1. The inspection and maintenance of machinery/equipment should only be performed after measures to prevent falling or runaway of the driven objects have been confirmed.
2. When the product is to be removed, confirm that the safety measures as mentioned above are implemented and the power from any appropriate source is cut, and read and understand the specific product precautions of all relevant products carefully.
3. Before machinery/equipment is restarted, take measures to prevent unexpected operation and malfunction.

4. SMC products cannot be used beyond their specifications. They are not developed, designed, and manufactured to be used under the following conditions or environments. Use under such conditions or environments is not allowed.

1. Conditions and environments outside of the given specifications, or use outdoors or in a place exposed to direct sunlight.
2. Use for nuclear power, railways, aviation, space equipment, ships, vehicles, military application, equipment affecting human life, body, and property, combustion equipment, entertainment equipment, emergency shut-off circuits, press clutches, brake circuits, safety equipment, etc., and use for applications that do not conform to standard specifications such as catalogs and operation manuals.
3. Use for interlock circuits, except for use with double interlock such as installing a mechanical protection function in case of failure. Please periodically inspect the product to confirm that the product is operating properly.

Caution

SMC develops, designs, and manufactures products to be used for automatic control equipment, and provides them for peaceful use in manufacturing industries.

Use in non-manufacturing industries is not allowed.

Products SMC manufactures and sells cannot be used for the purpose of transactions or certification specified in the Measurement Act of each country. The new Measurement Act prohibits use of any unit other than SI units in Japan.

Limited warranty and Disclaimer/ Compliance Requirements

The product used is subject to the following “Limited warranty and Disclaimer” and “Compliance Requirements”.

Read and accept them before using the product.

Limited warranty and Disclaimer

1. The warranty period of the product is 1 year in service or 1.5 years after the product is delivered, whichever is first.*2)
Also, the product may have specified durability, running distance or replacement parts. Please consult your nearest sales branch.
2. For any failure or damage reported within the warranty period which is clearly our responsibility, a replacement product or necessary parts will be provided.
This limited warranty applies only to our product independently, and not to any other damage incurred due to the failure of the product.
3. Prior to using SMC products, please read and understand the warranty terms and disclaimers noted in the specified catalog for the particular products.

*2) **Suction cups (Vacuum pads) are excluded from this 1 year warranty.**

A suction cup (vacuum pad) is a consumable part, so it is warranted for a year after it is delivered.

Also, even within the warranty period, the wear of a product due to the use of the suction cup (vacuum pad) or failure due to the deterioration of rubber material are not allowed by the limited warranty.

Compliance Requirements

1. The use of SMC products with production equipment for the manufacture of weapons of mass destruction (WMD) or any other weapon is strictly prohibited.
2. The exports of SMC products or technology from one country to another are governed by the relevant security laws and regulations of the countries involved in the transaction. Prior to the shipment of a SMC product to another country, assure that all local rules governing that export are known and followed.

Revision History

Edition B * A belt-driven slider type (LE2FB□H series) has been added.
* A guide rod type (LE2YG□H series) has been added.
* The number of pages has been increased from 52 to 88.

Edition C * The LE2R□H series rotary table has been added.
* The number of pages has been increased from 88 to 100.

Edition D * The LE2S(H) series slide table has been added.
* The number of pages has been increased from 100 to 136.

 **Safety Instructions** Be sure to read the “Handling Precautions for SMC Products” (M-E03-3) and “Operation Manual” before use.